

LOC		DIST		REVISIONS			
AD	00	P	LTR	DESCRIPTION	DATE	DMN	APVD
		P2	REVISED	PER ECO-11-004587	11MAR11	RK	HMR

- 1 OBSOLETE PART NO.
- 2 "AMP", PART NO. AND DATE CODE MARKED (WHITE), .062±.015 CHARS. WHEN HOUSING SIZE PERMITS
- 3 .046±.015 CHARS. MARKED (WHITE) FIRST AND EVERY 5TH CAVITY, ONE SIDE.
- 5 SUPERSEDED BY 3-87456-3.
- 6 SUPERSEDED BY 4-87456-5.
- 7 OBSOLETE PARTS: OBSOLETE CIS STREAMLINING PER D.RENAUD/D.SINISI

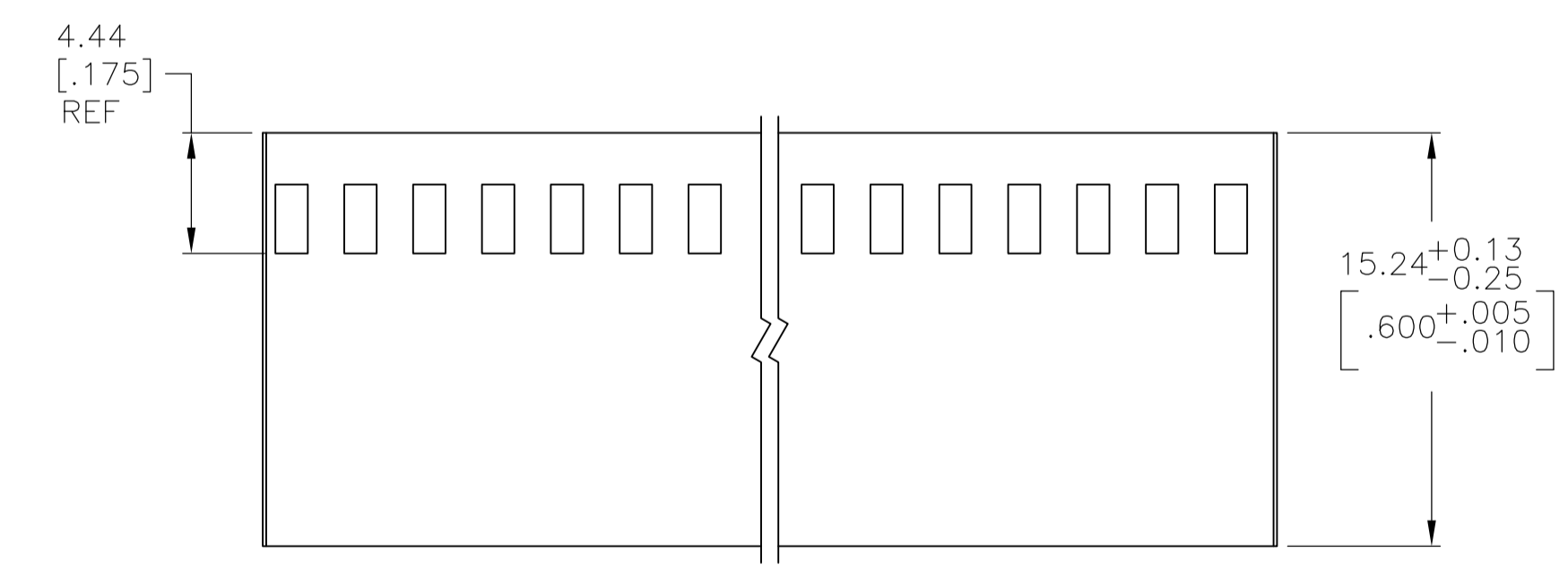
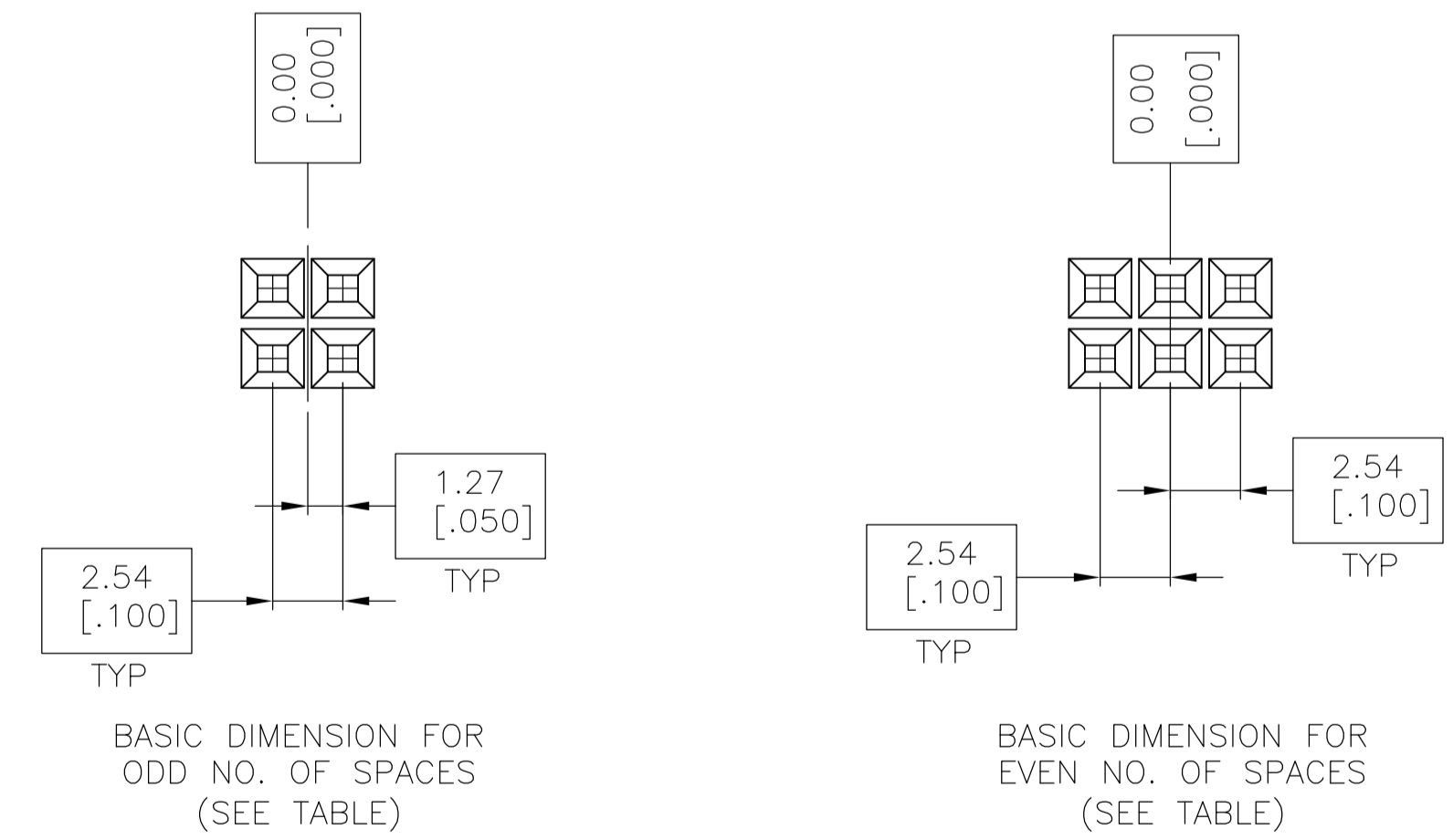
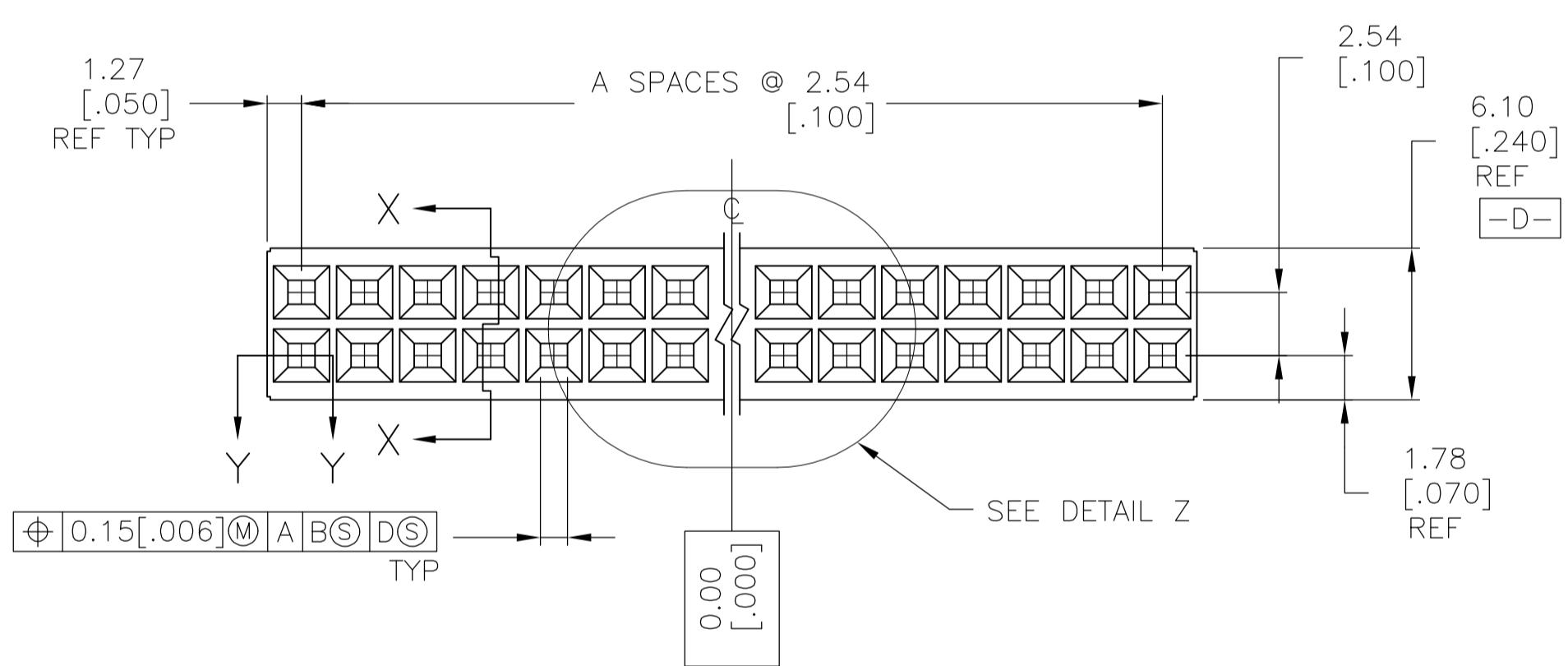
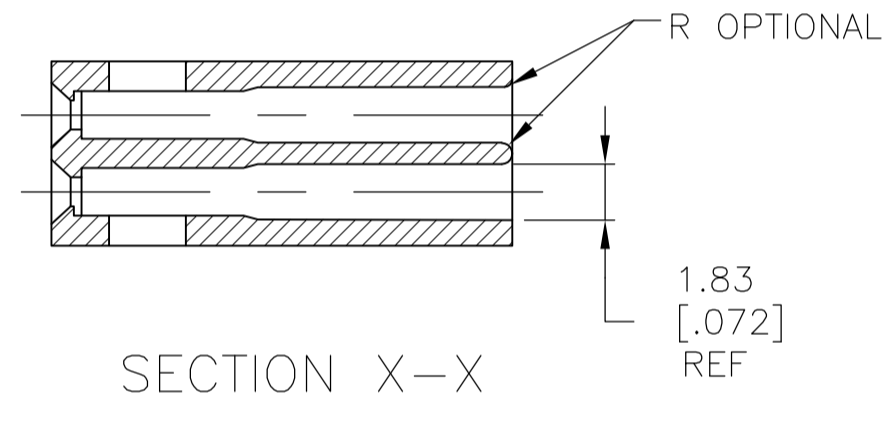
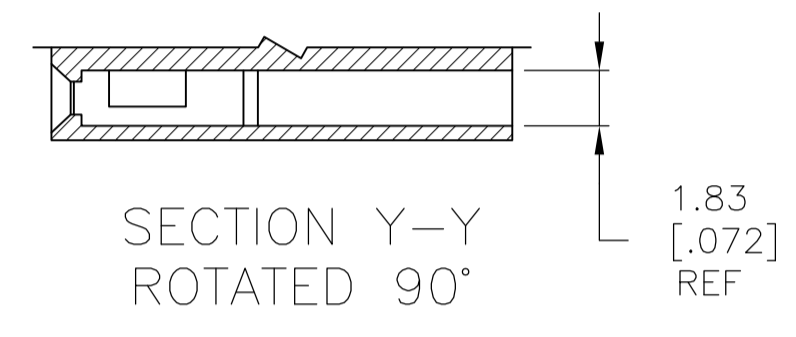
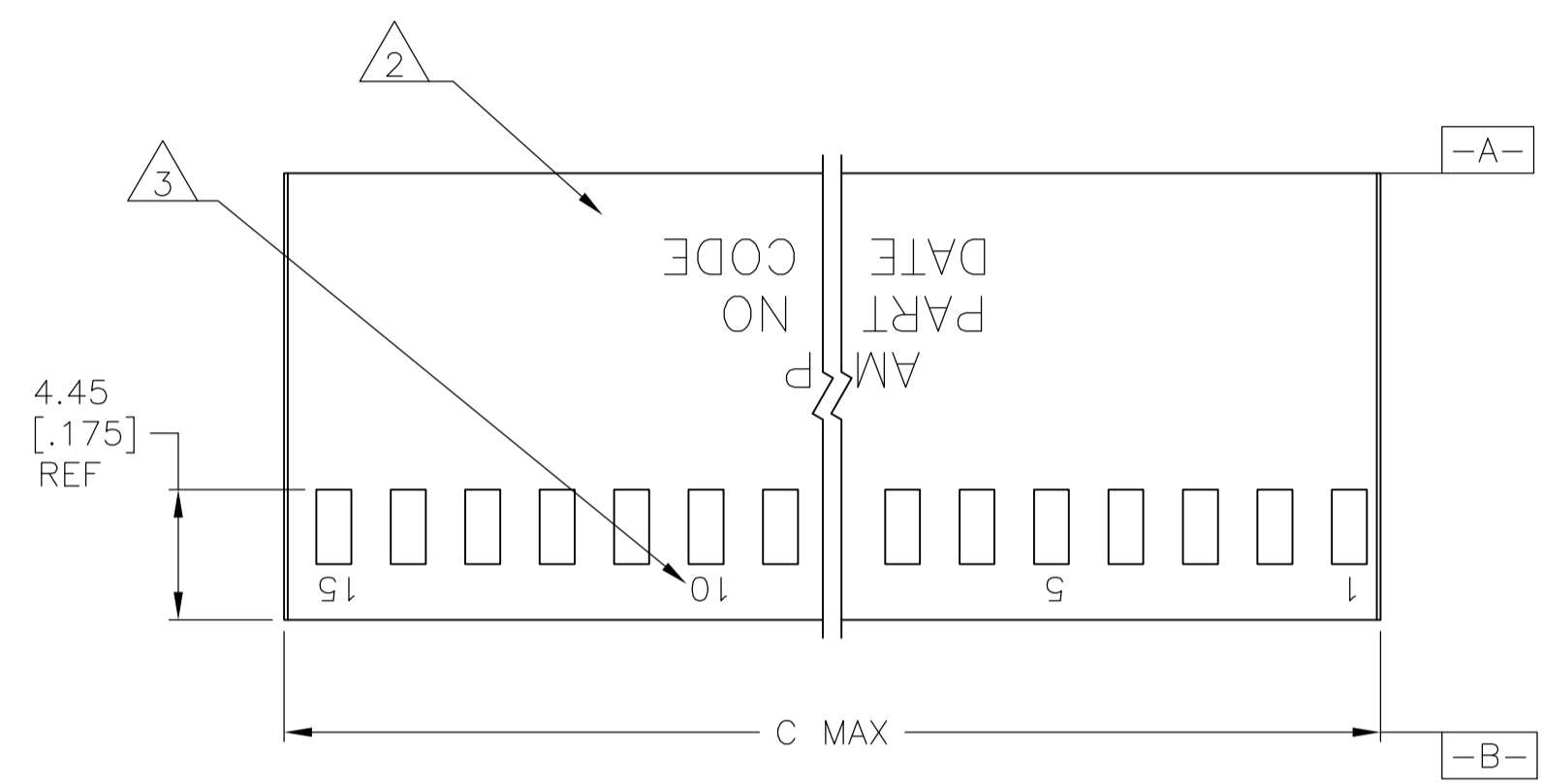

6-87456-5	81.28 [3.200]	31	64	6-87456-6
6-87456-3	73.66 [2.900]	28	58	6-87456-4
6-87456-1	71.12 [2.800]	27	56	6-87456-2
5-87456-9	60.96 [2.400]	23	48	6-87456-0
5-87456-7	83.82 [3.300]	32	66	5-87456-4
5-87456-5	88.90 [3.505]	34	70	5-87456-6
5-87456-3	2.67 [1.05]	-	2	-
5-87456-1	76.33 [3.005]	29	60	5-87456-2
4-87456-9	5.21 [2.05]	1	4	5-87456-0
4-87456-7	91.57 [3.605]	35	72	4-87456-8
4-87456-5	68.71 [2.705]	26	54	4-87456-6
4-87456-3	53.47 [2.105]	20	42	4-87456-4
4-87456-1	66.17 [2.605]	25	52	4-87456-2
3-87456-9	63.63 [2.505]	24	50	4-87456-0
3-87456-7	56.01 [2.205]	21	44	3-87456-8
3-87456-5	50.93 [2.005]	19	40	3-87456-6
3-87456-3	48.39 [1.905]	18	38	3-87456-4
3-87456-1	45.85 [1.805]	17	36	3-87456-2
2-87456-9	43.31 [1.705]	16	34	3-87456-0
2-87456-7	40.77 [1.605]	15	32	2-87456-8
2-87456-5	38.23 [1.505]	14	30	2-87456-6
2-87456-3	35.69 [1.405]	13	28	2-87456-4
2-87456-1	33.15 [1.305]	12	26	2-87456-2
1-87456-9	30.61 [1.205]	11	24	2-87456-0
SUP BY 1-87456-7	28.07 [1.105]	10	22	1-87456-8
1-87456-5	25.53 [1.005]	9	20	1-87456-6
1-87456-3	22.99 [905]	8	18	1-87456-4
1-87456-1	20.45 [805]	7	16	1-87456-2
87456-9	17.91 [705]	6	14	1-87456-0
87456-7	15.37 [605]	5	12	87456-8
87456-5	12.83 [505]	4	10	87456-6
87456-3	10.29 [405]	3	8	87456-4
87456-1	7.75 [305]	2	6	87456-2
PART NO. WITHOUT MARKING	C	A	NO. OF POSITIONS	PART NO. MARKED

THIS DRAWING IS A CONTROLLED DOCUMENT.

DIMENSIONS: mm [INCHES]

TOLERANCES UNLESS OTHERWISE SPECIFIED:

0. PLC	±	-
1. PLC	±	-
2. PLC	±	.02
3. PLC	±	.005
4. PLC	±	± 0° 30'

ANGLES: ± ± 0° 30'

MATERIAL: GLASS FILLED NYLON COLOR BLACK PER ASTM D4066

FINISH: -

WEIGHT: -

APPROVED: E. BRANDBERG 11-06-92, J. GESFORD 11-30-92, J. GESFORD 11-30-92

NAME: HOUSING, MOD IV DOUBLE ROW, .100X.100 C/L CRIMP SNAP-IN, SHORT ENTRY

SIZE: A1

SCALE: 4:1

SHEET: 1 OF 1

REV: P2

CUSTOMER DRAWING

Mouser Electronics

Authorized Distributor

Click to View Pricing, Inventory, Delivery & Lifecycle Information:

[TE Connectivity:](#)

[3-87456-6](#)