

LOC	DIST	REVISIONS			
GP	00	REV	DATE	BY	APPV
		A	02MAR2016	TX	SH

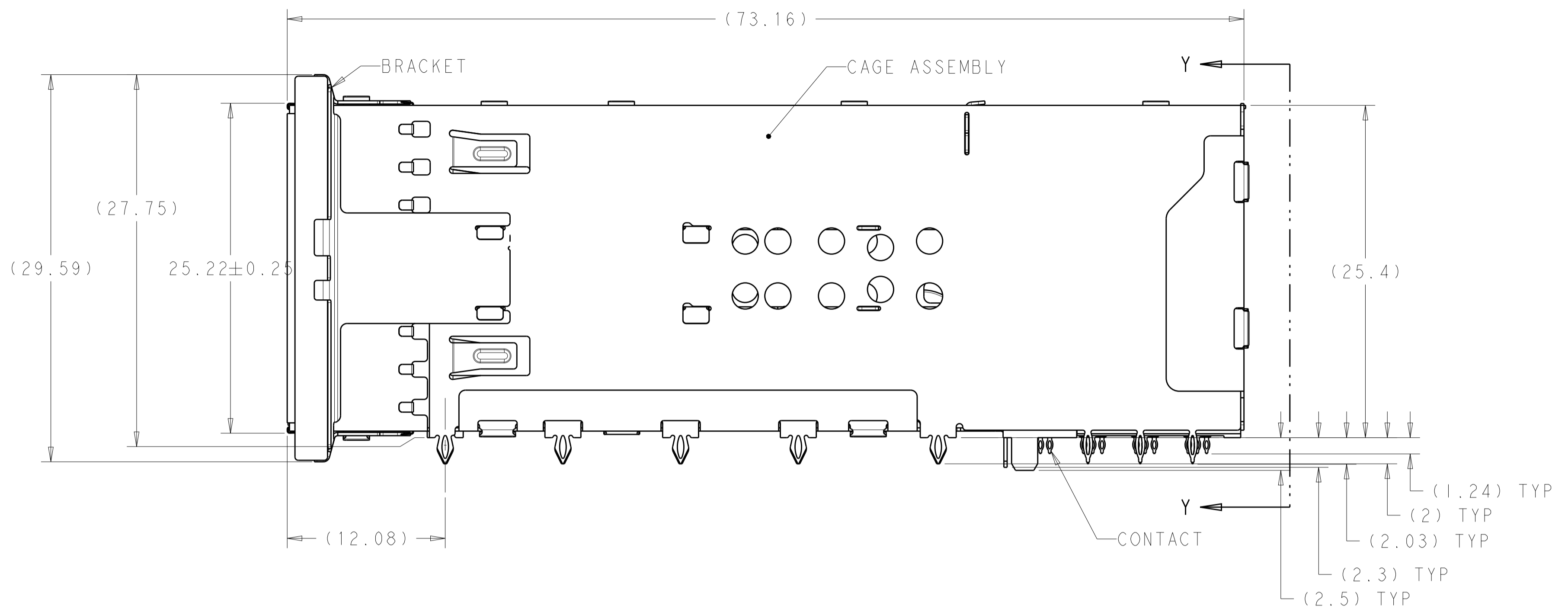
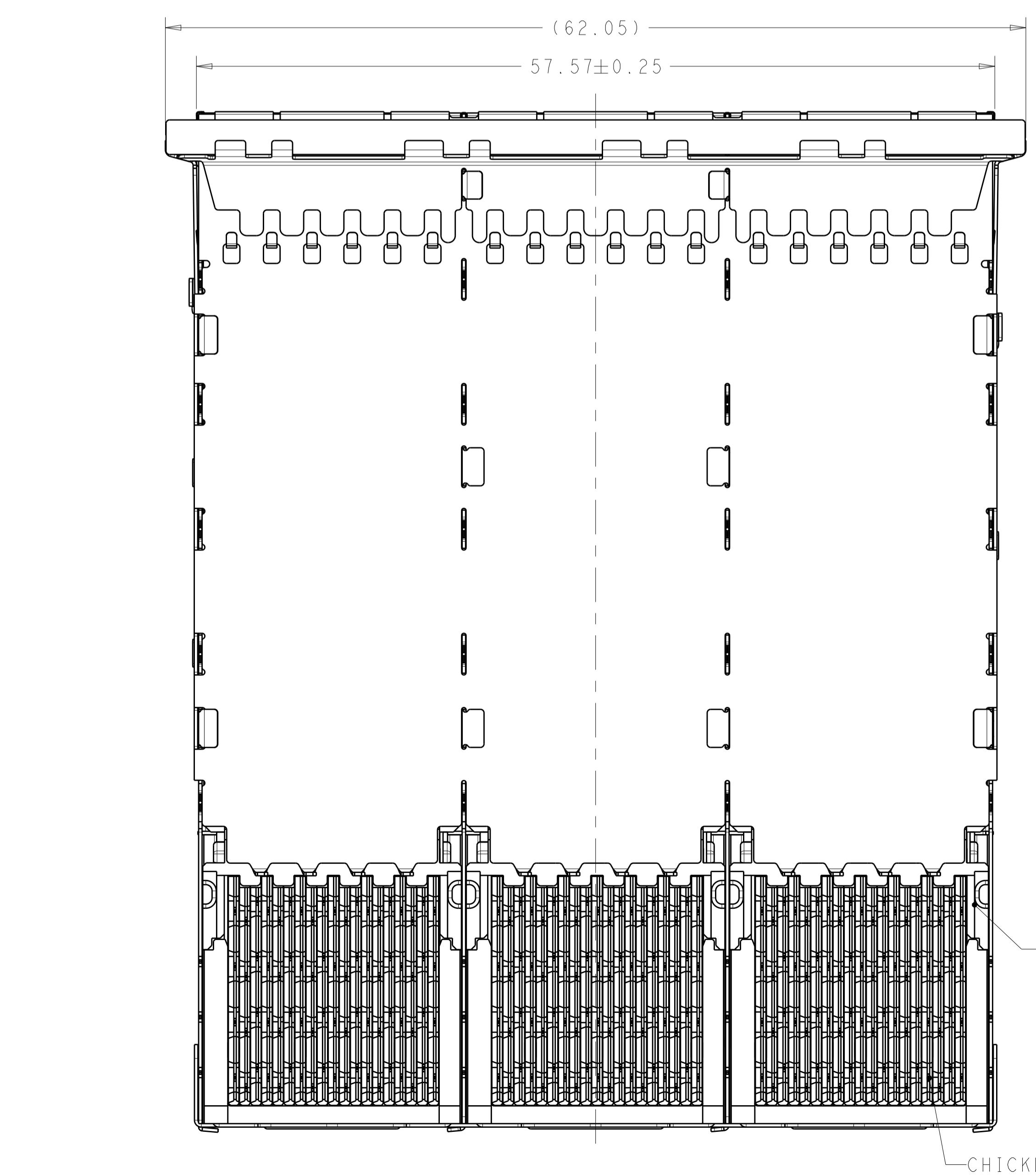
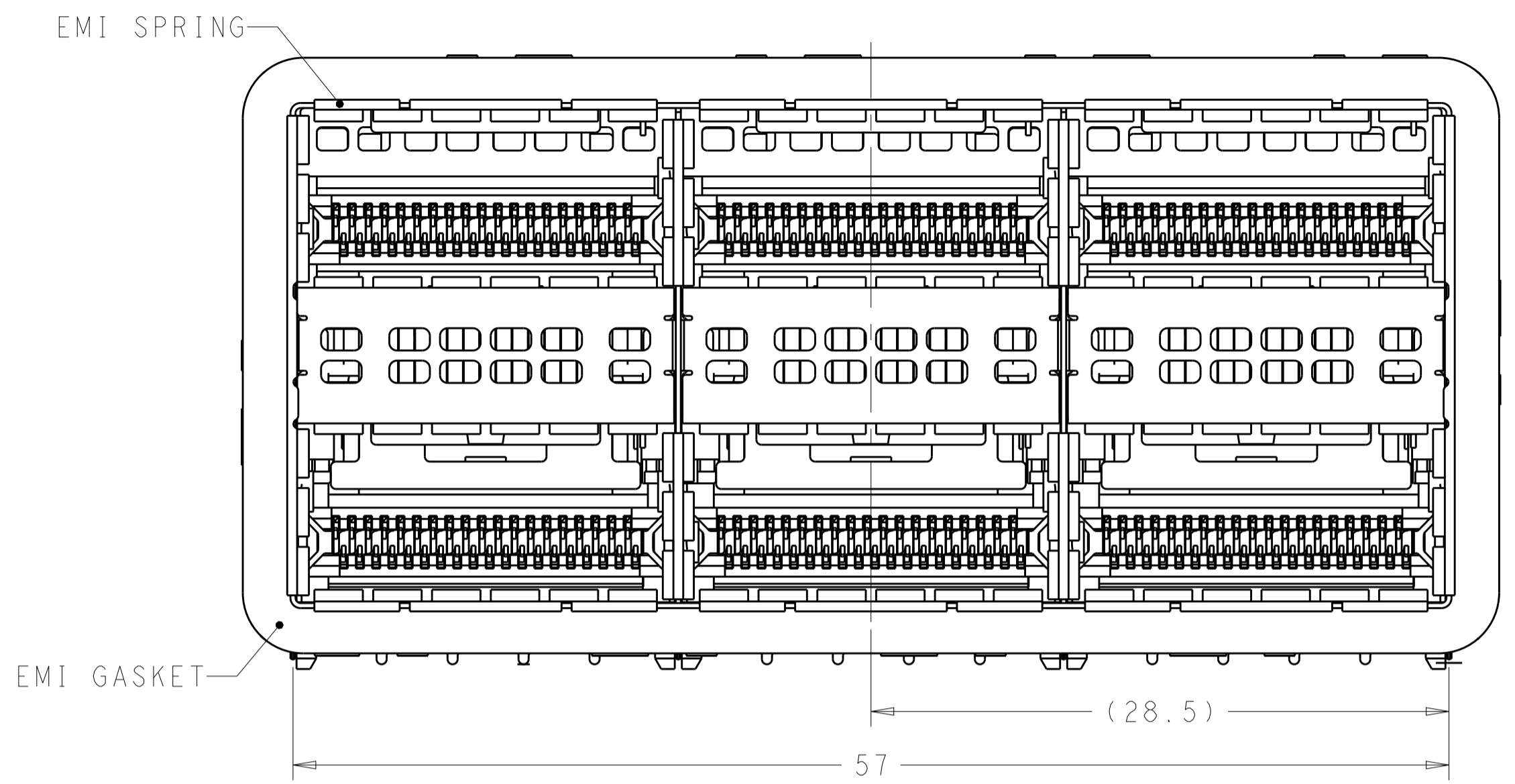

- MATERIALS:  
 CAGE ASSEMBLY- NICKEL SILVER ALLOY PER ASTM B 122.  
 BRACKET- NICKEL SILVER ALLOY PER ASTM B 122.  
 EMI SPRING- COPPER ALLOY, NICKEL PLATED.  
 EMI GASKET- PLATED FILLED SILICONE.  
 HOUSING- POLYESTER LCP WITH 94 V-0  
 CHICKLET- POLYESTER LCP WITH 94 V-0  
 CONTACT- COPPER ALLOY.  
 LIGHTPIPE- POLYCARBONATE WITH 94 V-0
- CONTACT FINISH: 0.76µm GOLD ON MATING END, 1.25µm TIN ON SOLDER TAIL, ALL OVER 1.27µm NICKEL.
- DATUM AND BASIC DIMENSION ESTABLISHED BY CUSTOMER.
- MINIMUM PCB THICKNESS OF 1.57.
- THE ENTIRE AREA OF THE CONNECTOR FOOTPRINT, INDICATED BY THE DASHED LINE, TO BE CONSIDERED THE KEEPOUT AREA FOR COMPONENTS.
- CROSS-HATCHED AREAS REPRESENT ZONES ON THE PCB THAT COME IN CONTACT WITH OR BE IN CLOSE PROXIMITY TO THE PLASTIC HOUSING OR THE CONNECTOR CAGE. INDICATED AREAS TO BE CONSIDERED TRACE FREE.
- PART NUMBER AND DATE CODE MADE IN APPROXIMATE AREA SHOWN.
- THESE HOLES ARE OPTIONAL WHEN PINS ON BACK OF CAGE ARE REMOVED.
- HATCHED AREA IS PLACEMENT ZONE FOR LED. LED SHOULD BE CENTERED WITHIN ZONE. RECOMMEND 0805 PACKAGE.
- CONTACT FINISH: 0.08µm MINIMUM GOLD OVER 0.68µm PALLADIUM-NICKEL ON MATING END, 1.25µm TIN ON SOLDER TAIL, ALL OVER 1.27µm NICKEL.

CONTACT FINISH	DESCRIPTION	PART NUMBER
10	LEFT INDICATOR DOWN	2227226-6
10	LEFT INDICATOR UP	2227226-5
10	NO LIGHTPIPE	2227226-4
2	LEFT INDICATOR DOWN	2227226-3
2	LEFT INDICATOR UP	2227226-2
2	NO LIGHTPIPE	2227226-1

THIS DRAWING IS A CONTROLLED DOCUMENT. DIMENSIONING AND TOLERANCING PER: ASME Y14.5M-2009. TOLERANCES UNLESS OTHERWISE SPECIFIED:

DIMENSIONS:	mm	0 PLC ±	1 PLC ±0.25	2 PLC ±0.15	3 PLC ±	4 PLC ±
ANGLES:		114-60015				

MATERIAL: SEE NOTE 1. FINISH: SEE NOTE 2.

APVD: M. SHIRK 01AUG2012. CHK: D. SZCZESNY 01AUG2012.

PRODUCT SPEC: 108-60102. APPLICATION SPEC: 114-60015.

WEIGHT: -.

CUSTOMER DRAWING. SCALE: 4:1. SHEET 1 OF 4. REV A.

STE TE Connectivity. CAGE AND CONNECTOR ASSEMBLY, WITH EMI GASKET, 2X3, ZQSFP+ STACKED. SIZE: A100779. C=2227226.

LOC		DIST		REVISIONS			
P	LTN	DESCRIPTION	DATE	DMN	APVD		
-	-	SEE SHEET 1	-	-	-		

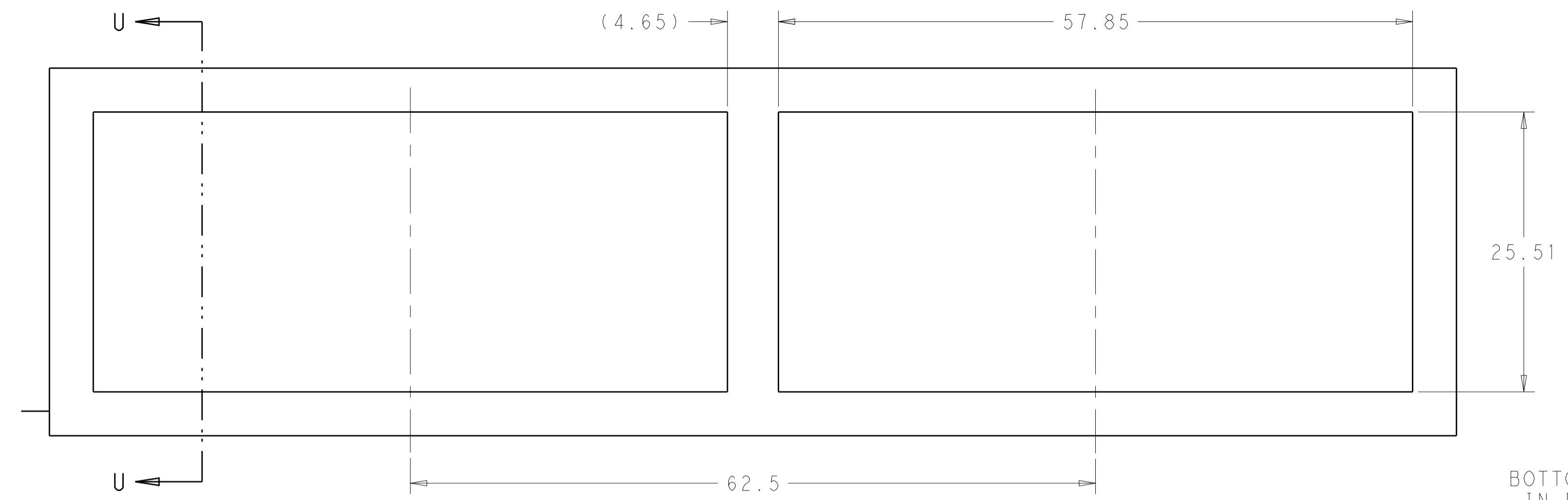

RECOMMENDED PANEL CUTOUT AND PC BOARD, PANEL POSITION  
 SCALE 3:1

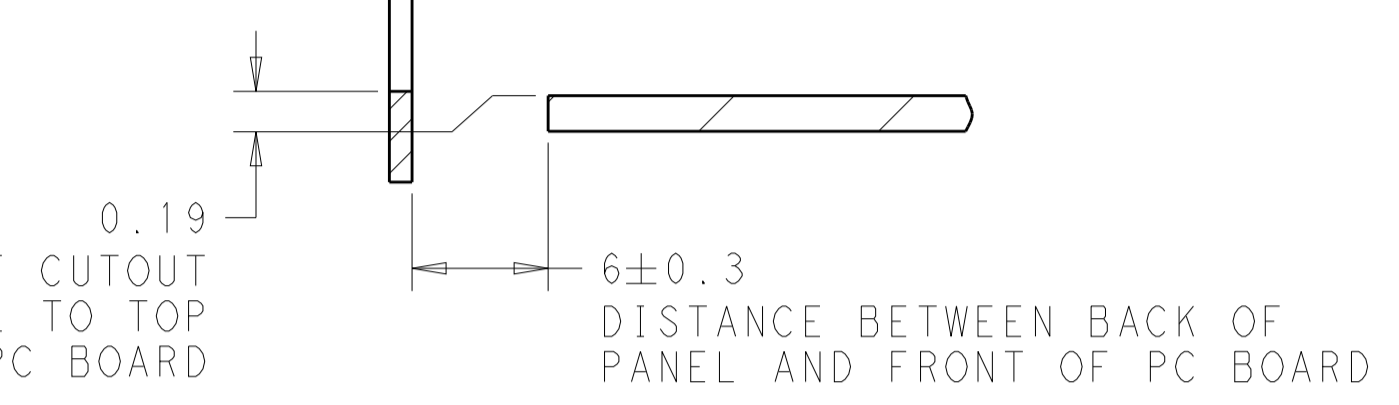

SECTION U-U

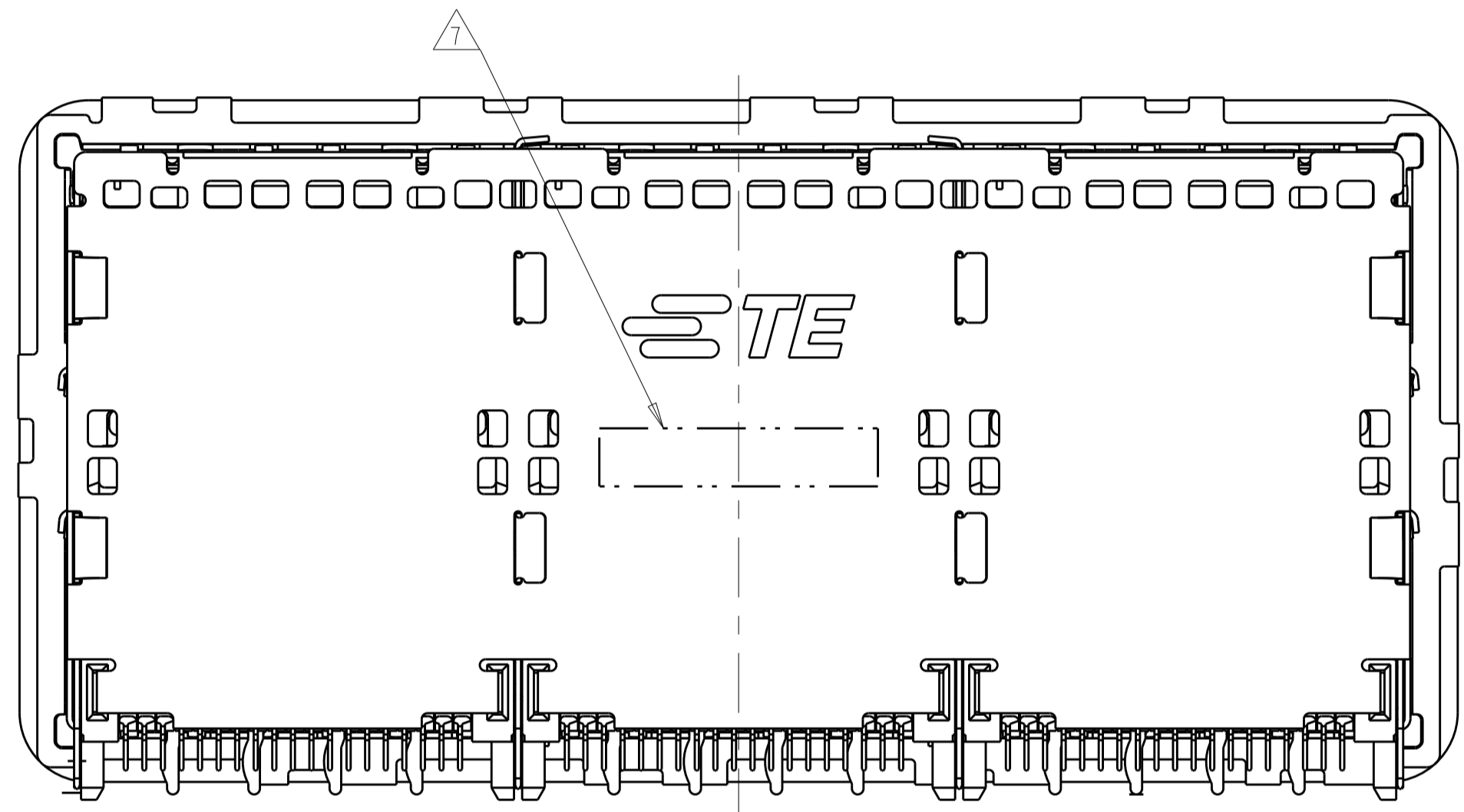

VIEW Y-Y

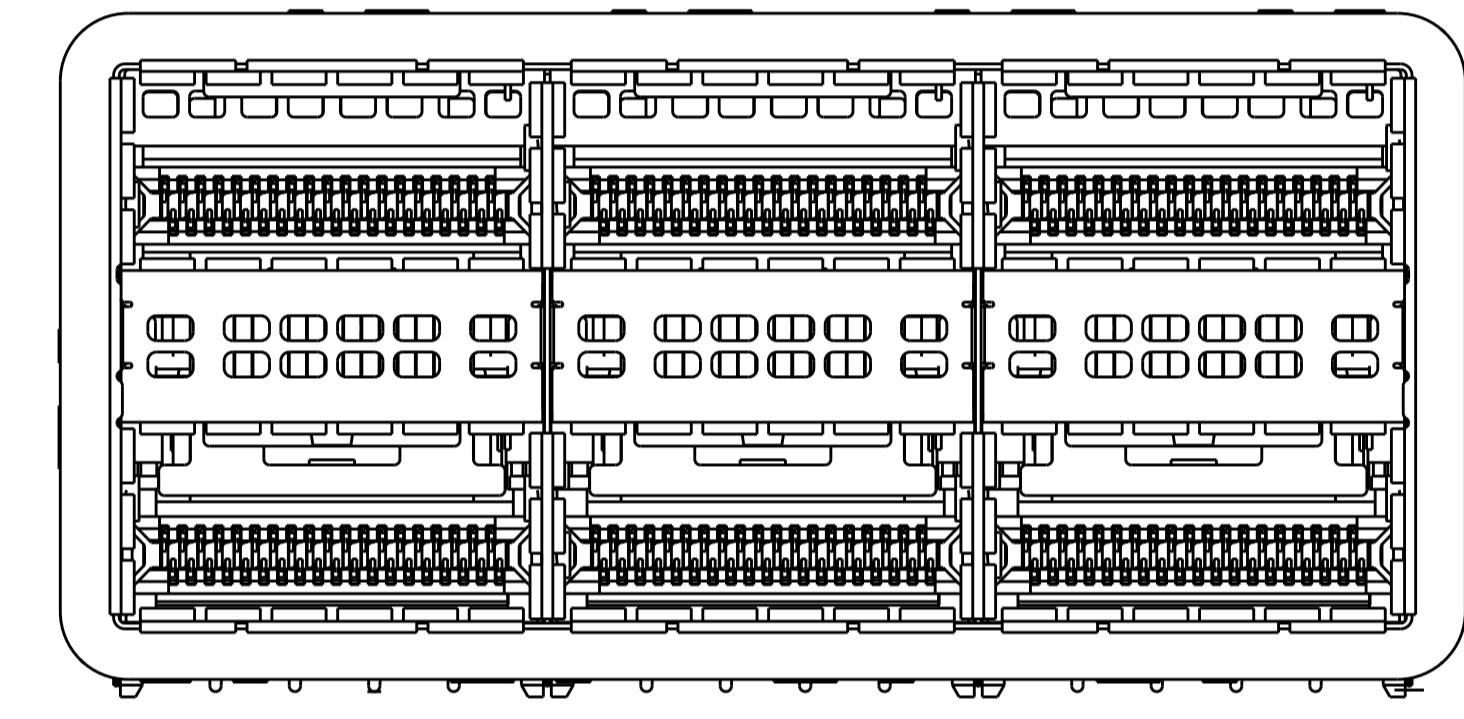

2227226-1/4  
 NO LIGHTPIPE IN ASSEMBLY  
 SCALE 3:1

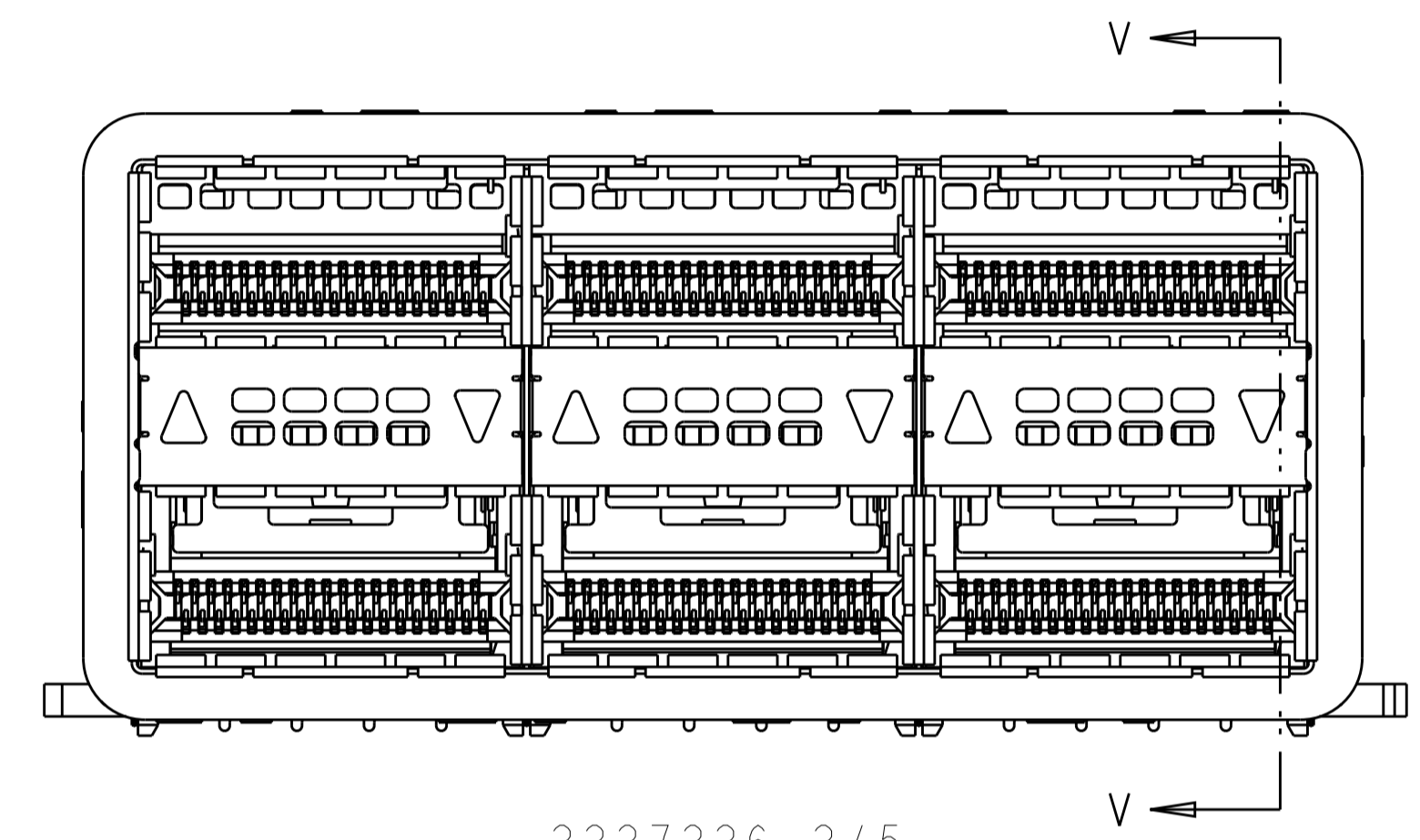

2227226-2/5  
 LEFT LIGHTPIPE INDICATOR POINTING TO UPPER PORT  
 SCALE 3:1

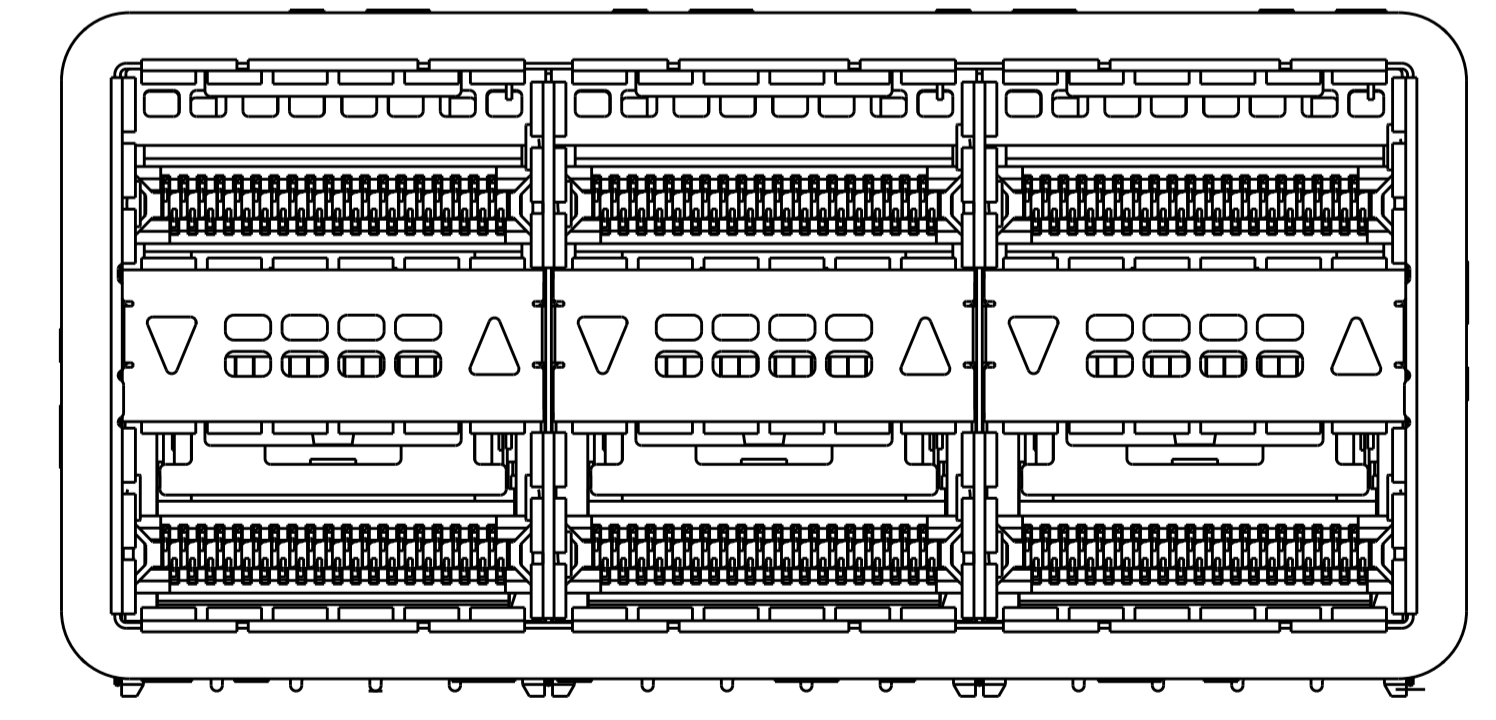

2227226-3/6  
 LEFT LIGHTPIPE INDICATOR POINTING TO LOWER PORT  
 SCALE 3:1

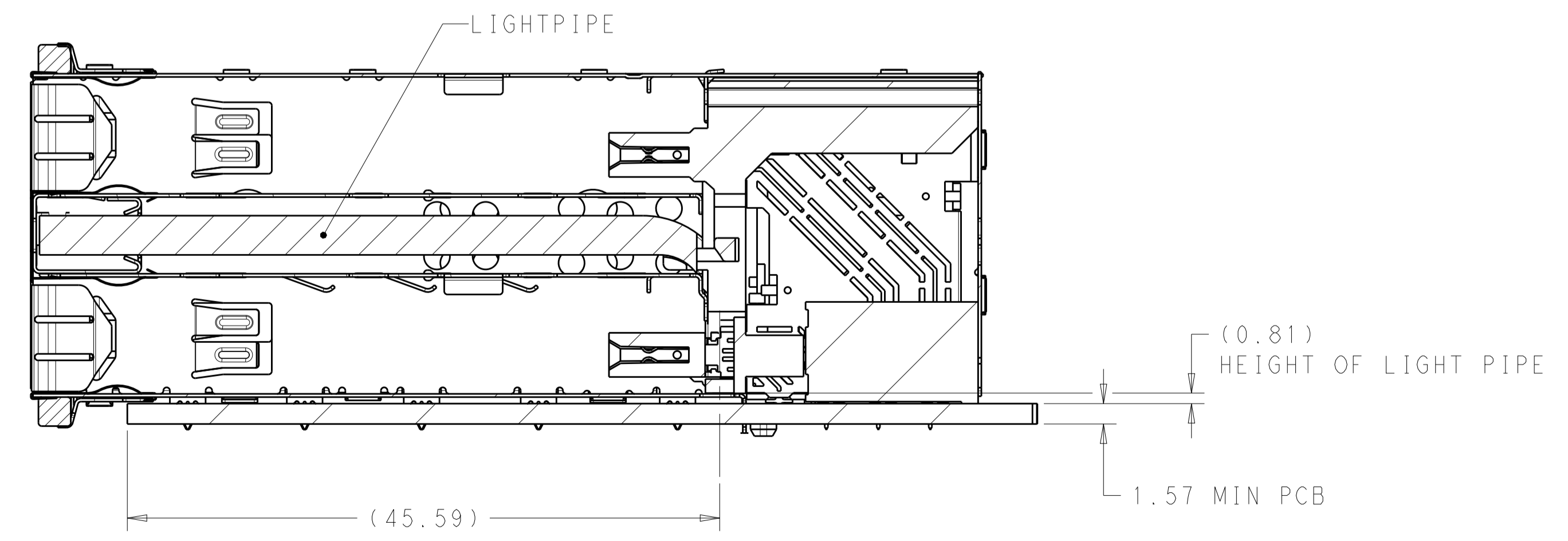

SECTION V-V  
 SCALE 3:1

THIS DRAWING IS A CONTROLLED DOCUMENT. DIMENSIONING AND TOLERANCING PER ASME Y14.5M-2009.		DMN: M. SHIRK 01AUG2012 CHK: D. SZCZESNY 01AUG2012 APVD: -	TE Connectivity NAME: CAGE AND CONNECTOR ASSEMBLY, WITH EMI GASKET, 2X3, ZQSFP+ STACKED
DIMENSIONS: mm	TOLERANCES UNLESS OTHERWISE SPECIFIED:	PRODUCT SPEC: 108-60102 APPLICATION SPEC: 114-60015	
MATERIAL: SEE NOTE 1	FINISH: SEE NOTE 2	WEIGHT: -	SIZE: A1 CAGE CODE: 00779 DRAWING NO: 2227226 CUSTOMER DRAWING
SCALE: 4:1			SHEET: 2 OF 4 REV: A

LOC		DIST		REVISIONS			
P	LTN	DESCRIPTION	DATE	DMN	APVD		
-	-	SEE SHEET 1	-	-	-		

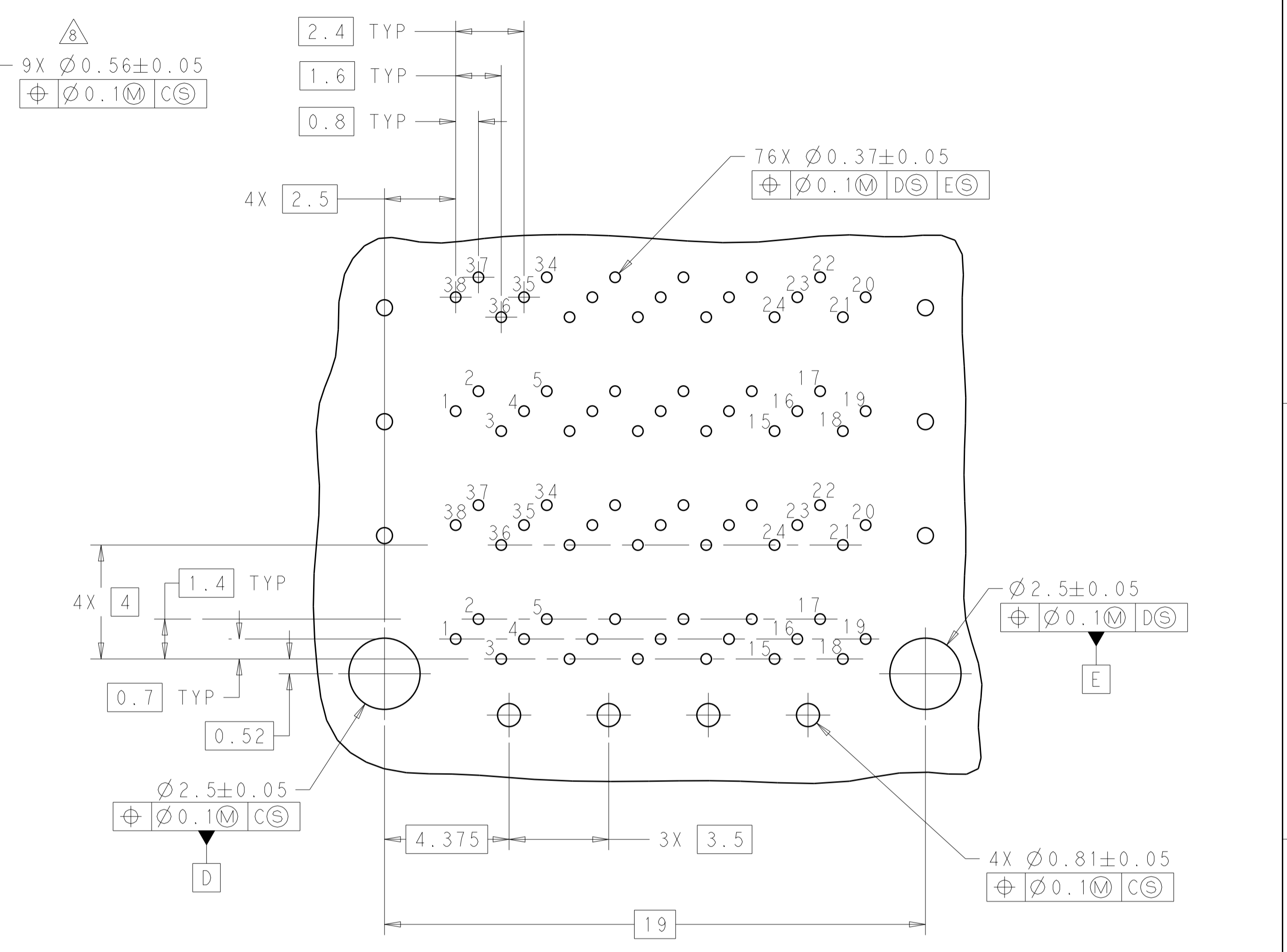
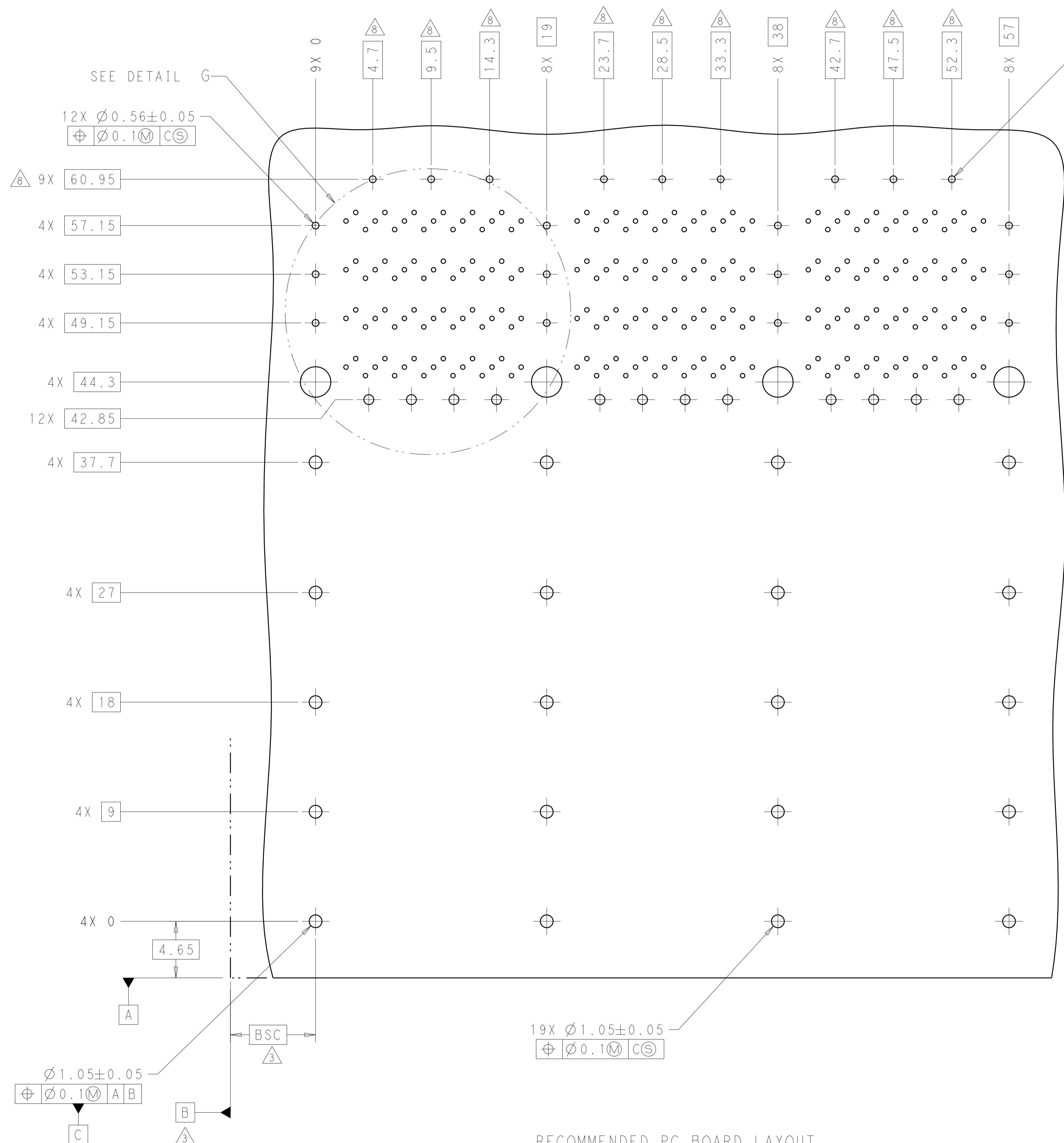

DETAIL G  
 3X INDIVIDUALLY  
 SCALE 8:1

RECOMMENDED PC BOARD LAYOUT  
 COMPONENT SIDE OF BOARD  
 PCB TOLERANCE:  $\pm 0.05$   
 SCALE 5:1

THIS DRAWING IS A CONTROLLED DOCUMENT. DIMENSIONING AND TOLERANCING PER ASME Y14.5M-2009.		DMN: M. SHIRK CHK: D. SZCZESNY APVD: -	01AUG2012 01AUG2012	TE Connectivity NAME: CAGE AND CONNECTOR ASSEMBLY, WITH EMI GASKET, 2X3, ZQSFP+ STACKED PRODUCT SPEC: 108-60102 APPLICATION SPEC: 114-60015 WEIGHT: - CUSTOMER DRAWING	RESTRICTED TO: -
DIMENSIONS: mm	TOLERANCES UNLESS OTHERWISE SPECIFIED:	SIZE: A100779	DRAWING NO: C=2227226		SCALE: 4:1
MATERIAL: SEE NOTE 1	FINISH: SEE NOTE 2	SCALE: 4:1		SHEET: 3 OF 4	REV: A

LOC		DIST		REVISIONS			
P.	LTN	DESCRIPTION	DATE	DMN	APVD		
-	-	SEE SHEET 1	-	-	-		

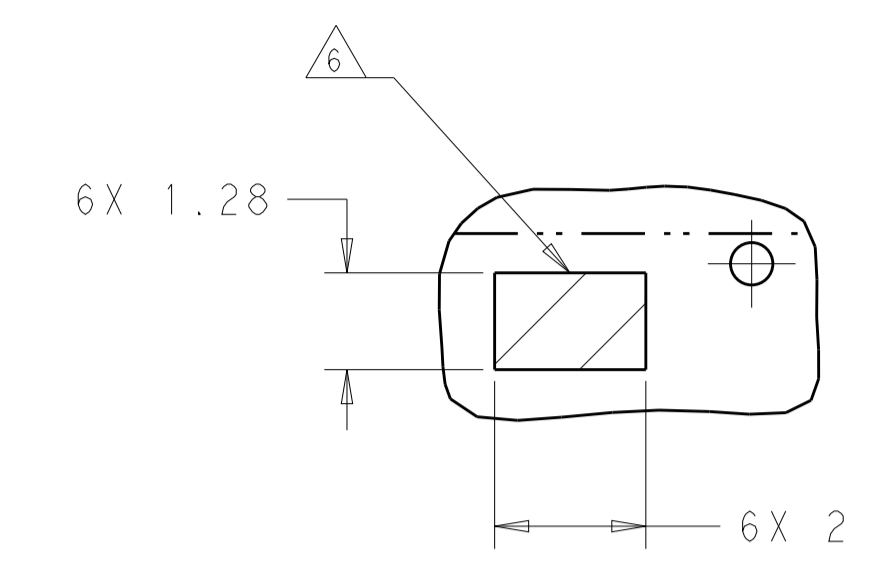
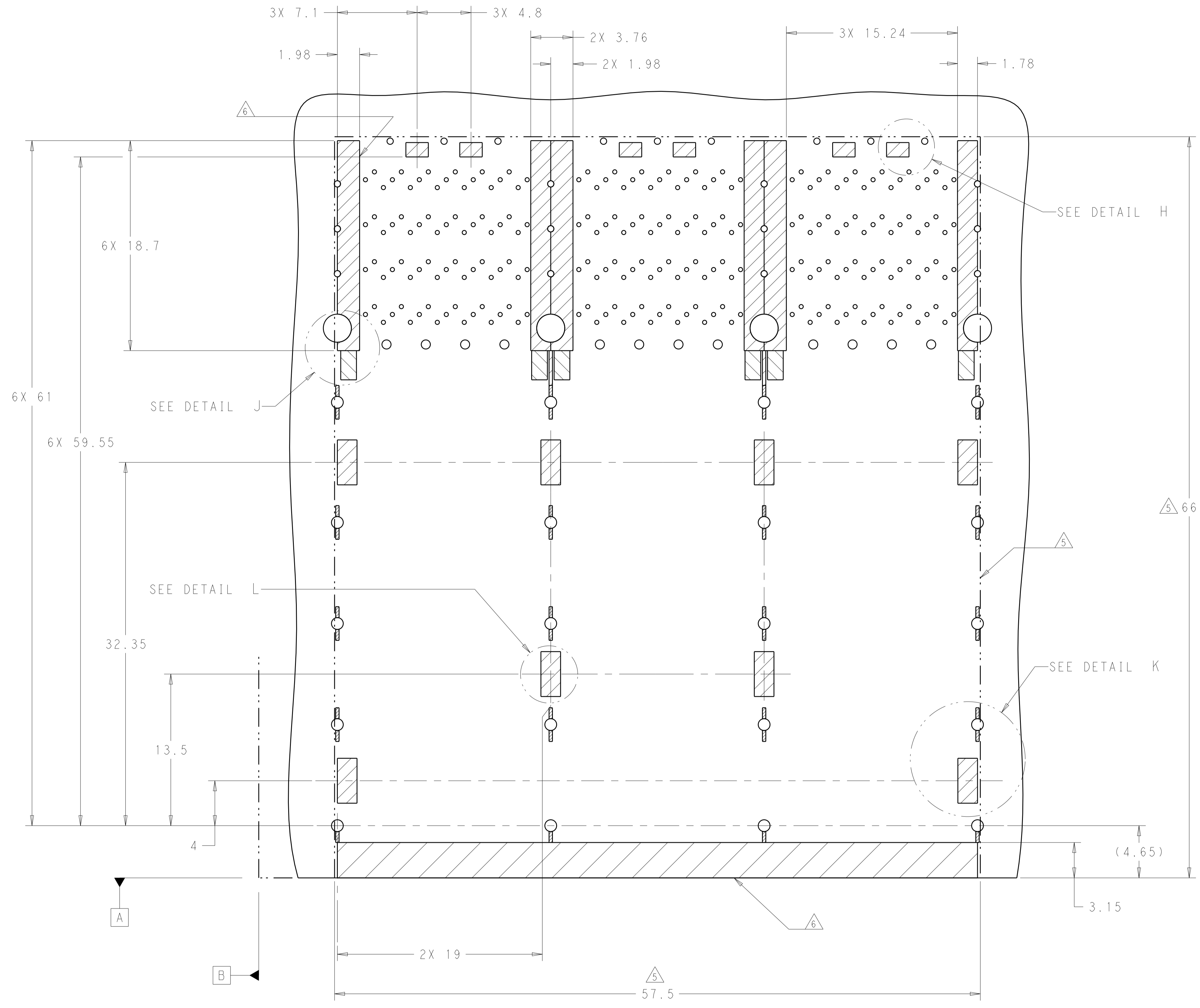

DETAIL H  
SCALE 10:1

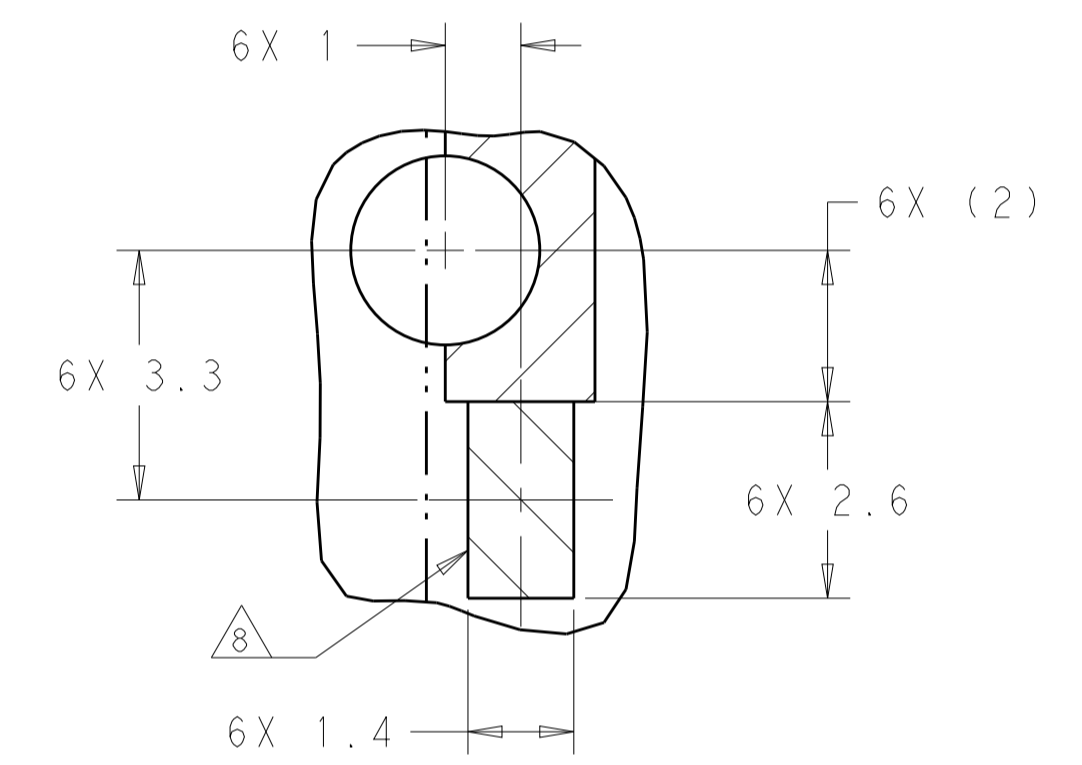

DETAIL J  
SCALE 10:1

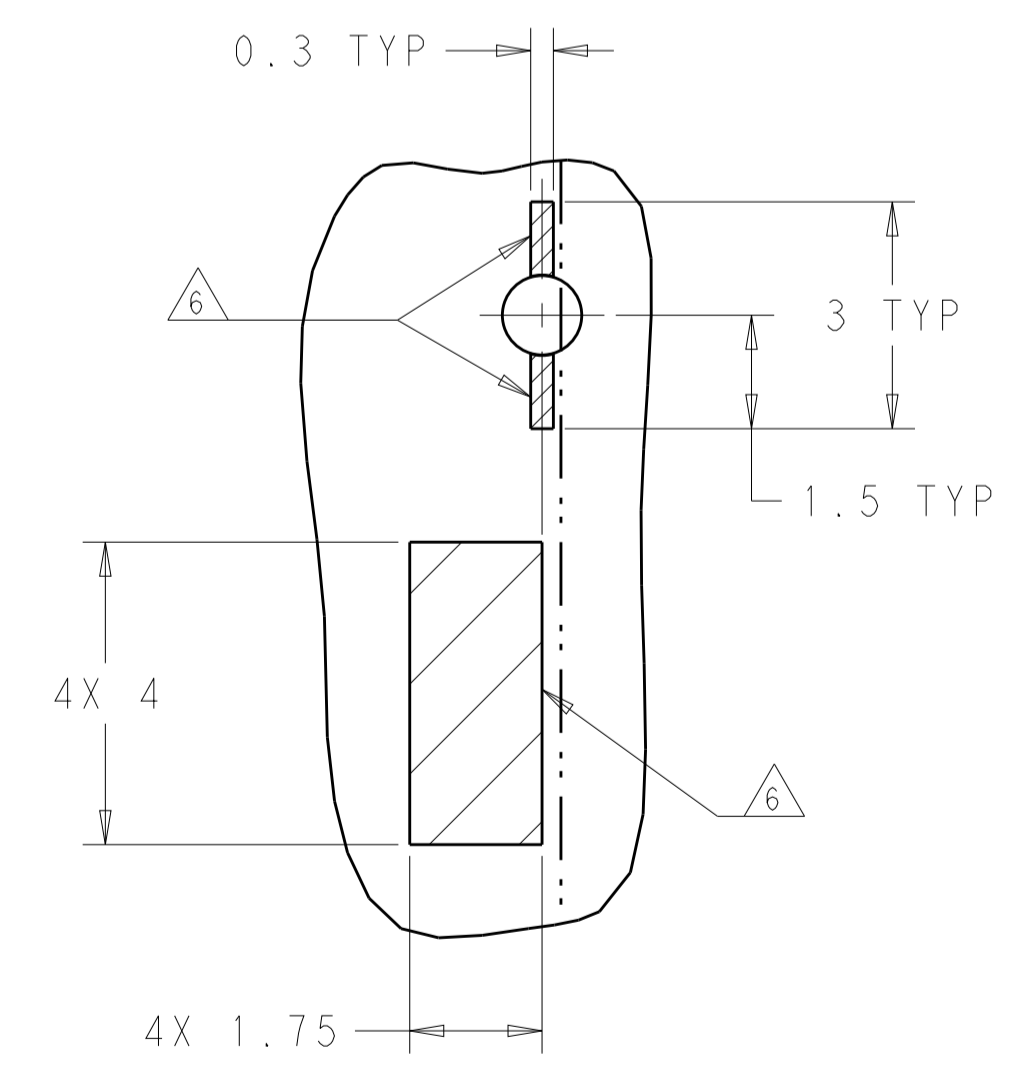

DETAIL K  
SCALE 10:1

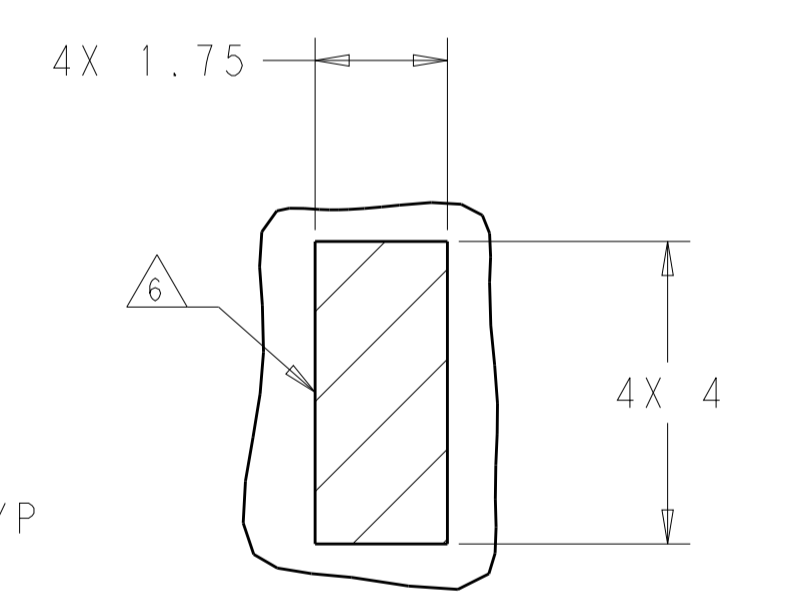

DETAIL L  
SCALE 10:1

KEEPOUT AREAS  
COMPONENT SIDE OF BOARD  
SCALE 5:1

THIS DRAWING IS A CONTROLLED DOCUMENT. DIMENSIONING AND TOLERANCING PER: ASME Y14.5M-2009		DMN: M. SHIRK 01AUG2012	TE Connectivity
TOLERANCES UNLESS OTHERWISE SPECIFIED:		CHK: D. SZCZESNY 01AUG2012	
DIMENSIONS:	mm	APVD:	NAME:
0 PLC	±	PRODUCT SPEC:	CAGE AND CONNECTOR ASSEMBLY,
1 PLC	±0.25	108-60102	WITH EMI GASKET, 2X3,
2 PLC	±0.15	APPLICATION SPEC:	ZQSPF+ STACKED
3 PLC	±	114-60015	SIZE: CAGE CODE: DRAWING NO:
4 PLC	±	WEIGHT:	A100779C=2227226
ANGLES:	±	CUSTOMER DRAWING	RESTRICTED TO:
MATERIAL:	FINISH:	SCALE: 4:1	SHEET 4 OF 4
SEE NOTE 1	SEE NOTE 2		REV A

# Mouser Electronics

Authorized Distributor

Click to View Pricing, Inventory, Delivery & Lifecycle Information:

[TE Connectivity:](#)

[2227226-3](#)