

REVISION(S)			
LTR	DESCRIPTION	INIT	APP'D
A	ERN#: 112609 RELEASE	E.T 4/18/08	B.P 4/18/08

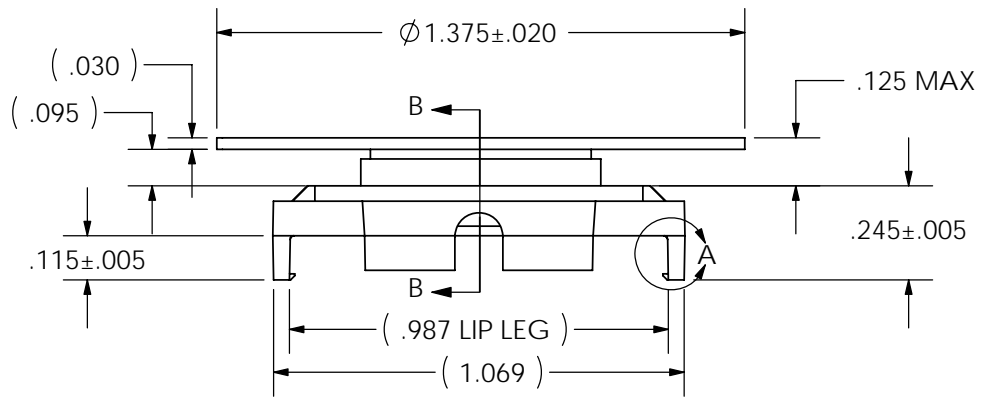

- MATERIAL:  
HEAT SINK: ALUM. (BLACK ANODIZE)  
CLIP: BLACK PEI (UL94-VO)
- BEFORE THE HEATSINK APPLICATION, THE USER SHOULD IDENTIFY THE SPECIFICATION OF MAXIMUM LOAD ON THE BGA PACKAGE.  
  
HEATSINK TORQUE SPECIFICATIONS CONVERTED TO FORCE.  
  
BARE DIE PACKAGE:  
1.5 POUND-FORCE INCH TORQUE = 8.5 POUND-FORCE (0.17 NEWTON METER TORQUE = 37.81 NEWTON)  
  
2.0 POUND-FORCE INCH TORQUE = 11.4 POUND-FORCE (0.23 NEWTON METER TORQUE = 50.71NEWTON)  
  
FULL SIZE LID PACKAGE:  
1.5 POUND-FORCE INCH TORQUE = 8.3 POUND-FORCE (0.17 NEWTON METER TORQUE = 36.92NEWTON)  
  
2.0 POUND-FORCE INCH TORQUE = 11.1 POUND-FORCE (0.23 NEWTON METER TORQUE = 49.38NEWTON)
- REMOVE CLIP WITH REMOVAL TOOL P/N: 1542616-1.
- RoHS COMPLIANT AND CERTIFIED.
- CUSTOMER WILL NOT ACCEPT STANDARD CHIP COOLER PACKAGING. ANTISTATIC PACKAGING REQUIRED.

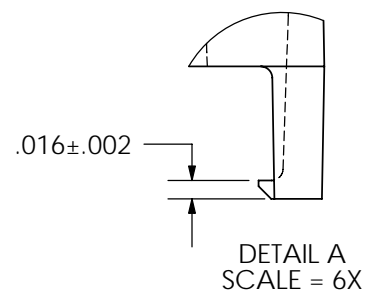
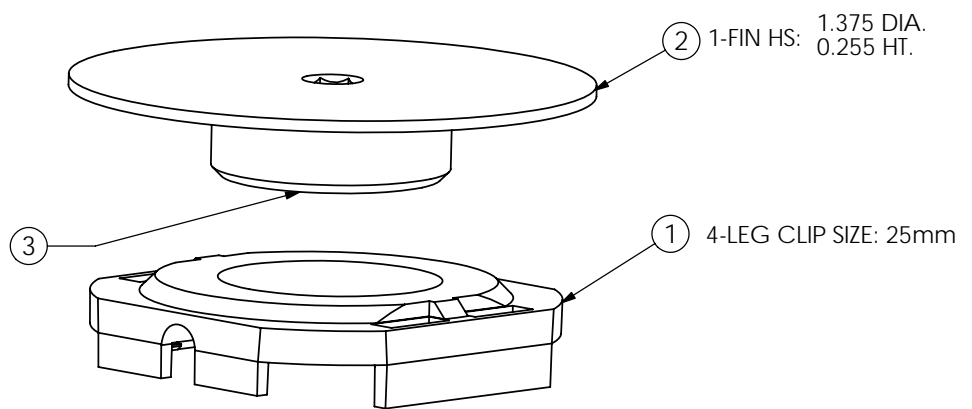
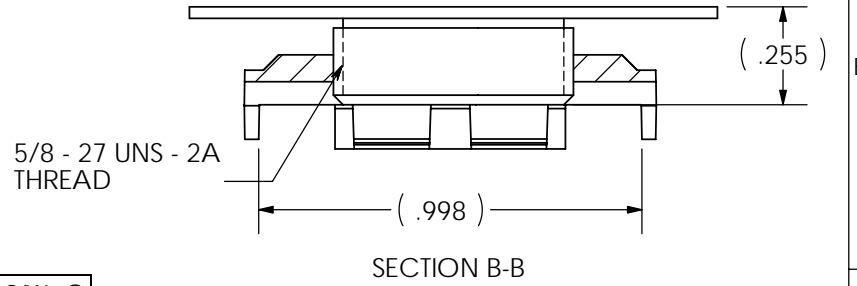

Power	° C/W @ Ambient	° C/W @ 200 LFM	° C/W @ 400 LFM	° C/W @ 600 LFM
5 Watts	14.41	8.95	6.47	5.00
10 Watts	12.71	8.86	6.79	4.94
15 Watts	11.58	8.77	6.76	4.85

**CUSTOMER DRAWING**

SPECIFICATIONS ARE SUBJECT TO CHANGE WITHOUT NOTICE

ITEM	DESCRIPTION	QTY	Tyco Electronics Norwood, Massachusetts 02062			CONFIDENTIAL PROPERTY OF TYCO ELECTRONICS. NOT TO BE DISCLOSED TO OTHERS. REPRODUCED OR USED FOR ANY PURPOSES EXCEPT AS AUTHORIZED IN WRITING BY AN AUTHORIZED OFFICIAL OF TYCO. MUST BE RETURNED TO TYCO ON DEMAND, ON COMPLETION OF ORDERS OR OTHER PURPOSES FOR WHICH LENT.		TITLE: <b>25mm HEATSINK ASSEMBLY</b>						
1	MOUNTING CLIP	1	DO NOT SCALE	DRAWN BY: E.TAO	DATE 4/18/08	MATERIAL:  SEE NOTE	DIMENSIONS ARE IN: INCHES	SCALE: 2:1	PART NO: <b>1963836-1</b>	SHEET: 1 OF 1				
2	HEAT SINK	1		ENGINEER: B.PETROCELLI	DATE 4/18/08						FINISH:  SEE NOTE	SIZE: <b>A</b>	DWG. NO. <b>C-1963836</b>	REV: <b>A</b>
3	INTERFACE	1		FILENAME	PROJECT									

# Mouser Electronics

Authorized Distributor

Click to View Pricing, Inventory, Delivery & Lifecycle Information:

[TE Connectivity:](#)

[1963836-1](#)