

THIS COPY IS PROVIDED ON A RESTRICTED BASIS AND IS NOT TO BE USED IN ANY WAY DETRIMENTAL TO THE INTERESTS OF PANDUIT CORP.

PANDUIT PART NUMBER	STUD SIZE	DIMENSIONS in.				
		A ±.040	W ±.010	C ±.020	M ±.040	H ±.010
PN10-8FF-2K	#8	1.05 (26.67)	.38 (9.65)	.22 (5.59)	.80 (20.32)	.17 (4.32)
PN10-10FF-2K	#10	1.05 (26.67)	.38 (9.65)	.22 (5.59)	.80 (20.32)	.20 (5.08)

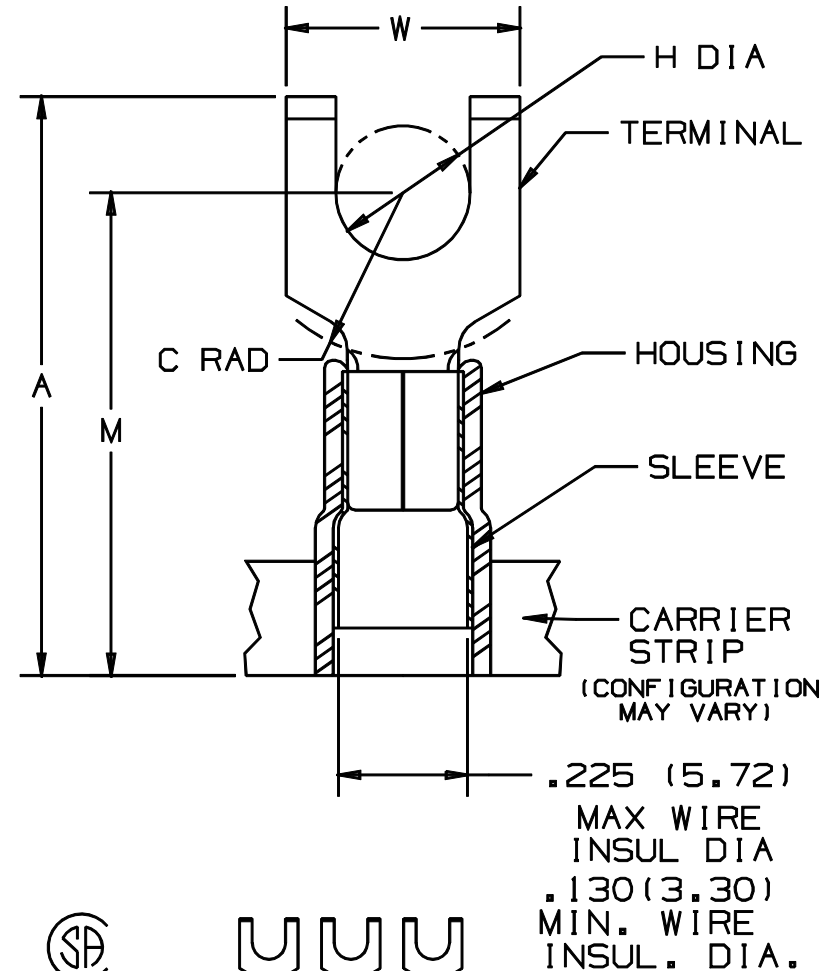

NOTES :

- UL LISTED AND CSA CERTIFIED FOR :
  - 600 V MAX. VOLTAGE RATING
  - 221°F (105°C) MAX. TEMP. RATING
  - #12-10 AWG (2.5-6.0 mm<sup>2</sup>) SOLID OR STRANDED, COPPER WIRE
- PACKAGE QTY. : 2K = 2000 PCS.  
CONTINUOUS MOLDED CARRIER STRIP
- MATERIAL :
  - STAMPING - .04" THK COPPER, TIN PLATED
  - HOUSING - YELLOW NYLON
  - SLEEVE - BRASS, TIN PLATED
- DIMENSIONS IN BRACKETS ARE IN MILLIMETERS
- INSTALLATION TOOLS :
  - PRESSES - CP-851, CP-860, CP-861
  - APPLICATOR - CA-800
  - DIE INSERTS - CD-800-3
- WIRE STRIP LENGTH:  $9/32^{+1/32}_{-0}$  (7.1<sup>+0.8</sup><sub>-0</sub>)



LISTED  
587H  
E52164



CERTIFIED  
LR31212

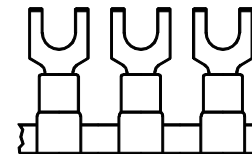

A41091\_05

05	1/01	SAB		FILE SPEC. WAS N41091AA_PCD_04				TINLEY PARK, ILLINOIS			
04	5/99	ED		UPDATED "A" & "M" DIM.S. AND MODIFIED DIMENSIONAL TOLERANCES	07670						
03	12/96	JAMBRLS		ADDED DIM., "MIN INSUL. DIA."	05388	LA	DBH				
REV	DATE	BY	CHK	DESCRIPTION	ECN	CUST	PM	DRAWN BY FES	CHK'D LA	SCALE NONE	DRAWING NO. A41091

# Mouser Electronics

Authorized Distributor

Click to View Pricing, Inventory, Delivery & Lifecycle Information:

Panduit:

[PN10-10FF-2K](#) [PN10-8FF-2K](#)