

ASSY NO.	MS NO.	DIMENSIONS										
		A +.050 -.060	B THREAD (PLATED) CLASS 2A	C ±.031	D MIN FULL THD	E +.010 -.000	F +.020 -.010	G +.000 -.010	H DIA +.010 -.000	J ±.005	K	L DIA +.004 -.002
10-169208	3102E8S	.422	.5000-28 UNEF	.484	.391	.562	.672	.297	.375	.594	.875	.120
10-169210	10S-		.6250-24 NEF						.500	.719	1.000	
10-169211	10SL-		.6250-24 NEF						.625	.719	1.000	
10-169212	12S-		.7500-20 UNEF		.450				.625	.812	1.094	
10-169213	12-	.672	.7500-20 UNEF	.672	.625	.750	.860	.484	.625	.812	1.094	
10-169214	14S-	.422	.8750-20 UNEF	.484	.450	.562	.672	.297	.750	.906	1.188	
10-169215	14-	.672	.8750-20 UNEF	.672	.625	.750	.860	.484	.750	.906	1.188	
10-169216	16S-	.422	1.0000-20 UNEF	.484	.450	.562	.672	.297	.875	.969	1.281	
10-169217	16-	.672	1.0000-20 UNEF	.672	.625	.750	.860	.484	.875	.969	1.281	
10-169218	18-	.641	1.1250-18 NEF				.891	.453	1.000	1.062	1.375	
10-169220	20-		1.2500-18 NEF						1.125	1.156	1.500	
10-169222	22-		1.3750-18 NEF						1.250	1.250	1.625	
10-169224	24-	.578	1.5000-18 NEF			.812	.953		1.375	1.375	1.750	.147
10-169228	28-	.578	1.7500-18 NS			.812	.953		1.625	1.562	2.000	.147
10-169232	32-	.500	2.0000-18 NS			.875	1.031	.438	1.875	1.750	2.250	.173
10-169236	36-		2.2500-16 UN						2.062	1.938	2.500	
10-169240	40-		2.5000-16 UN						2.312	2.188	2.750	

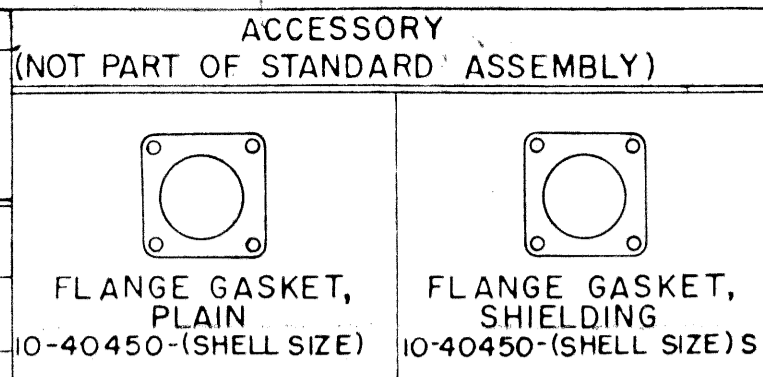

NO	REV	DESCRIPTION	DATE	BY
1	32525-374	10-69840 (NOTE 6)	6-20-57	BARTKOW
2	33750-61	ADD NOTE 9 & DATA	1-21-58	MOORE
3	35535-8	REV 'C' COLUMN	9-2-59	SIEDSMAN
4	36235-4	ADD NOTE 10, REV SOLDER WELL DATA	2-1-60	DONLON
5	36525-329	REM PD COL (B THD); REV NOTE 3; ADD NOTE 11	3-17-60	LALLI
A1	49062-1	(MFG); REM NOTE 10	5-24-69	Small
A2	49525-635	REV NOTE 11	9-22-69	Small
A3	51175-1	REM NOTE 9, REVISION LETTER (C) (31'LCS)	11-3-69	Small
A4	53249-13	ADD. 9-3895 (PROSPEC); REV STAMP NOTE	1-6-72	Small

11. FOR PART NUMBERS 10-169217-13, 10-169218-15, SEE INDIVIDUAL DRAWINGS.
- 10.
- 9.
8. SEE WORK ORDER FOR PERMISSIBLE ADDITIONAL OR ALTERNATE STAMPING.
7. INSERTS & CONTACTS ARE NOT REMOVABLE.
6. SEE DRAWINGS 10-169608 THRU 10-169640 & DRAWINGS 10-169808 THRU 10-169840 FOR MATING PLUG ASSEMBLIES.
5. TO COMPLETE ASSEMBLY NUMBER & MS. NO., ADD APPLICABLE INSERT ARRANGEMENT SUFFIX TO BASE NUMBERS LISTED ABOVE. TO DETERMINE DESIRED INSERT ARRANGEMENT, SEE PARTS LISTS 10-169208 THRU 10-169240.
4. INCREASE A DIMENSION BY .312 FOR SIZE "O" CONTACT ONLY.
3. FOR CONTACT SIZE, SPACING & SERVICE RATING, SEE DRAWINGS MS33680 THRU MS33690.
2. DIMENSIONS MUST BE MAINTAINED WHEN INSERTS ARE PRESSED FIRMLY AGAINST INDICATED SHOULDER.
1. THE UNITS ILLUSTRATED MEET THE PERFORMANCE REQUIREMENTS OF MS 3102E PER SPEC MIL-C-5015C.

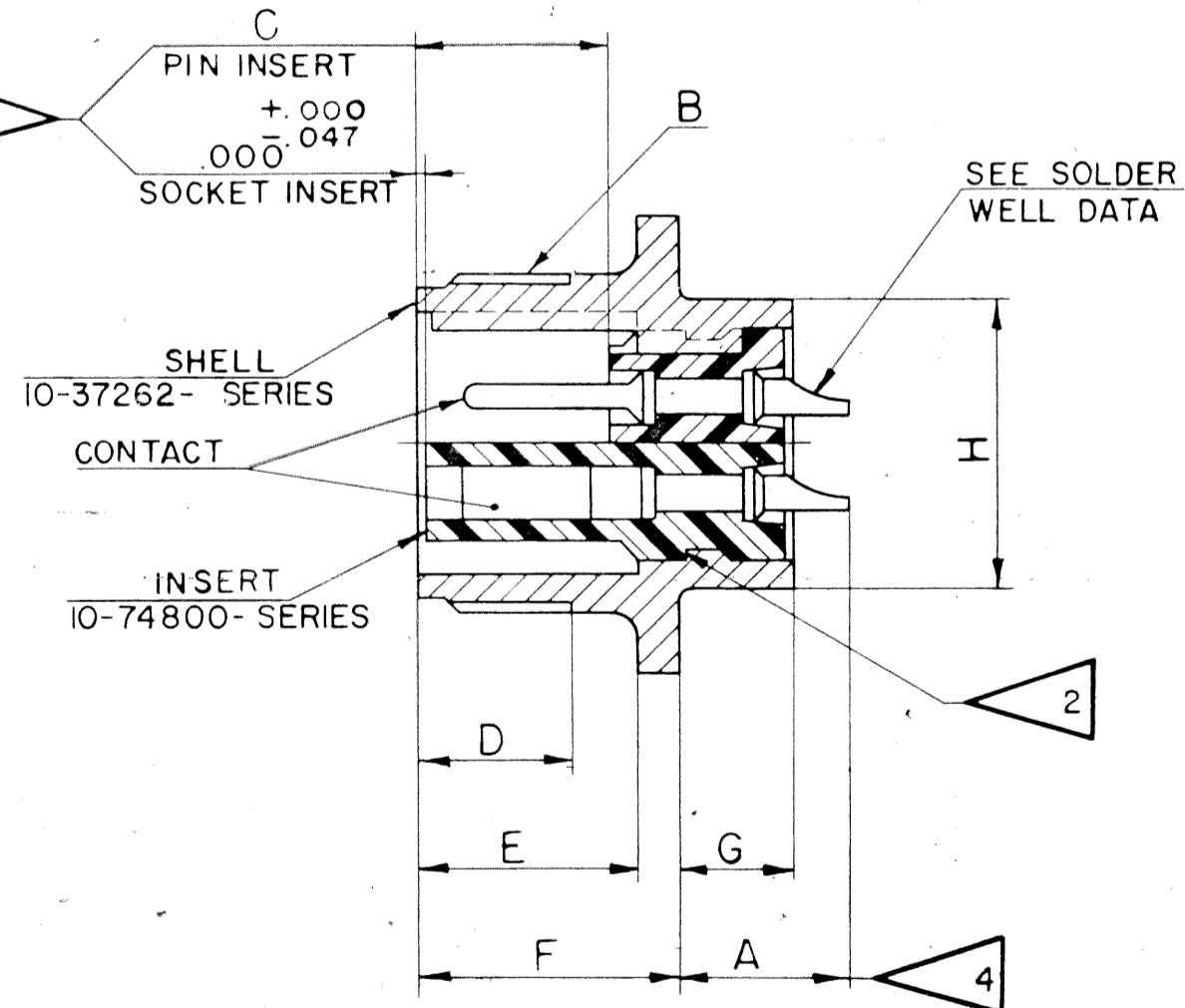
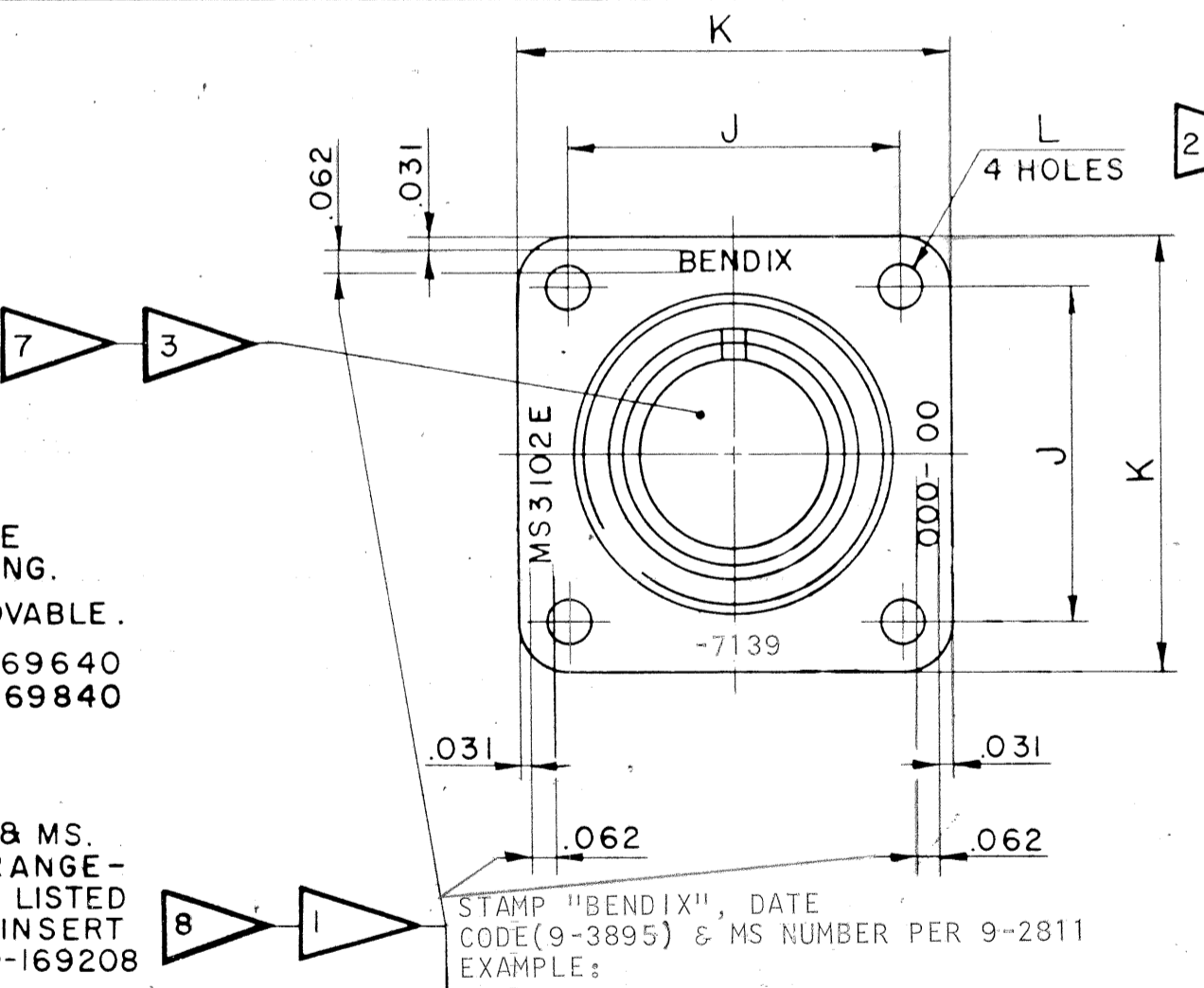

10-169208 THRU
10-169240

SOLDER WELL DATA						
CONTACT SIZE	0	4	8	12	16	16M
WELL DIA	469 ⁺⁰⁰⁵ ₋₀₀₃	332 ⁺⁰⁰⁵ ₋₀₀₃	209 ⁺⁰⁰⁴ ₋₀₀₂	116 ⁺⁰⁰⁴ ₋₀₀₂	078 ⁺⁰⁰⁴ ₋₀₀₂	078 ⁺⁰⁰⁴ ₋₀₀₂
WELL DEPTH	625	625	500	375	188	250

MATERIAL SPEC.	PROCESS SPEC.	SCINILLA MAGNETO DIVISION BENDIX AVIATION CORPORATION BIDNEY, N.Y. U.S.A.		TOLERANCES UNLESS OTHERWISE SPECIFIED	
	TEST 9-3106-1 ASSY 9-3238-1 SEE NOTE 1 9-2437-9-2811 9-3895	NAME		ORIGINALS	
HEAT TREAT SPEC.		CONNECTOR, ELECTRICAL RECEPTACLE, TYPE SG (1)FB		NEXT ASSEMBLY	
TOOL ALC.	COM REF 22569-8	Q. MAN	CHECKER	DATE	APPROVED
		A. SMY	B. SMY	4-24-57	5-9-58
					SCALE
					NONE
		SUPERSEDES		AND IS NOT INTERCHANGEABLE	
		SUPERSEDED BY		10-169208 THRU 10-169240	
		DWG SIZE C		TABCODE 77820	