

Customer Information Sheet

(INCHES)

DRAWING No.: H2177-XX

SHEET 2 OF 2

IF IN DOUBT - ASK



NOT TO SCALE

THIRD ANGLE PROJECTION

ALL DIMENSIONS IN mm

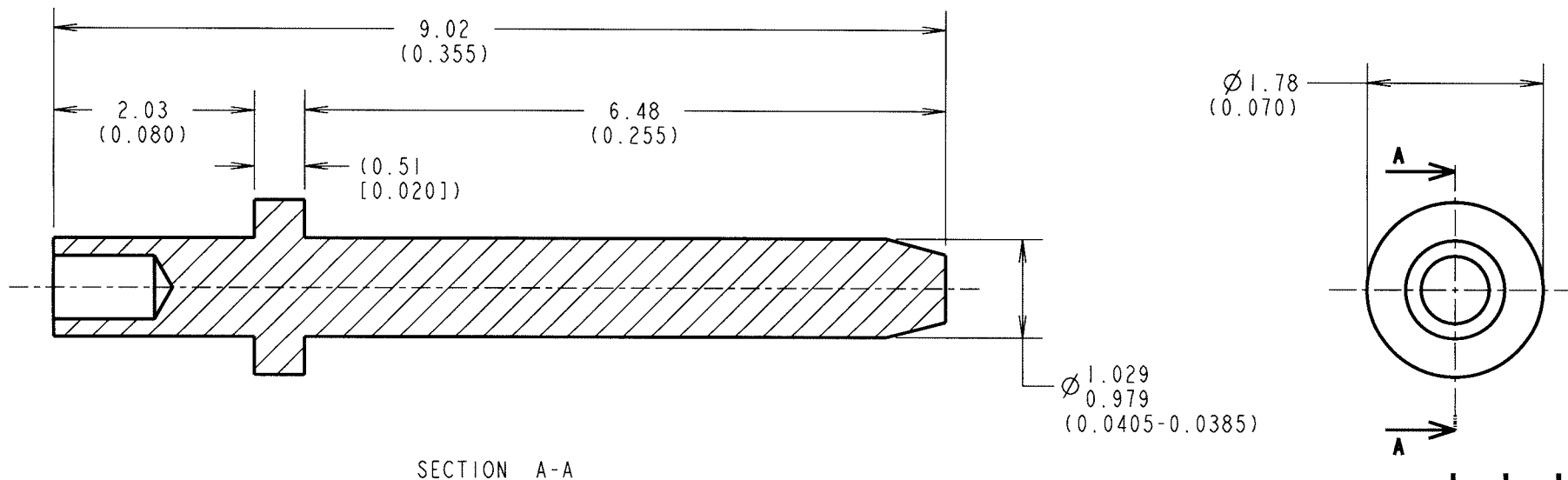

SECTION A-A

NOTES:

1. RECOMMENDED MOUNTING HOLE SIZE = $\varnothing 1.04-1.14$ mm.
2. RECOMMENDED PANEL THICKNESS = 1.6mm.
3. ALL TOLERANCES ARE ± 0.13 mm (0.005") UNLESS OTHERWISE STATED.
4. TO BE USED WITH PUNCH & DIE TOOL No. Z2177-00.

ORDER CODE:

H2177-XX

FINISH: _____
05 = GOLD

JAE	1	11.02.05	----
NAME	ISS.	DATE	C/NOTE
APPROVED: <i>[Signature]</i>			
CHECKED: <i>[Signature]</i>			
DRAWN: J. ENRIGHT			
CUSTOMER REF.:			
ASSEMBLY DRG:			

HARWIN

HARWIN INC U.S.A. TEL: (812) 542 2540 FAX: (812) 542 2541	HARWIN PLC U.K. TEL: 023 9231 4545 FAX: 023 9231 4590	HARWIN PTE SINGAPORE TEL: 65 6779 4909 FAX: 65 6779 3868
--	--	---

THIS DRAWING AND ANY INFORMATION OR DESCRIPTIVE MATTER SET OUT HEREON ARE CONFIDENTIAL AND COPYRIGHT PROPERTY OF THE HARWIN GROUP AND MUST NOT BE DISCLOSED, LOANED, COPIED OR USED FOR MANUFACTURING, TENDERING OR FOR ANY OTHER PURPOSE WITHOUT THEIR WRITTEN PERMISSION.

TOLERANCES
~~X = ± 1 mm~~
~~X.X = ± 0.25 mm~~
~~X.XX = ± 0.10 mm~~
~~X.XXX = ± 0.01 mm~~
 ANGLES = $\pm 5^\circ$
 UNLESS STATED

MATERIAL:
BRASS CW603N TO BS EN 12164 (CuZn36Pb3)
FINISH: 0.1 μ GOLD
S/AREA: mm²

TITLE: TERMINAL PIN
DRAWING NUMBER: H2177-XX
 SHT 2 OF 2

Mouser Electronics

Authorized Distributor

Click to View Pricing, Inventory, Delivery & Lifecycle Information:

[Harwin:](#)

[H2177-05](#)