

THIS DRAWING IS UNPUBLISHED. RELEASED FOR PUBLICATION

© COPYRIGHT - BY - ALL RIGHTS RESERVED.

LOC	DIST	REVISIONS			
P	LTR	DESCRIPTION	DATE	DWN	APVD
ES	00	A1	UPDATED PER ECR-14-004955	27JUL2014	T.Q W.H

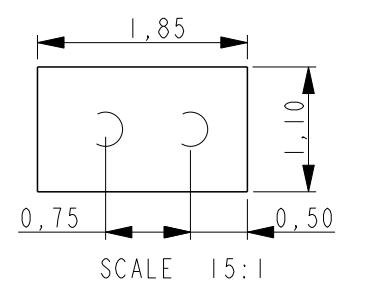
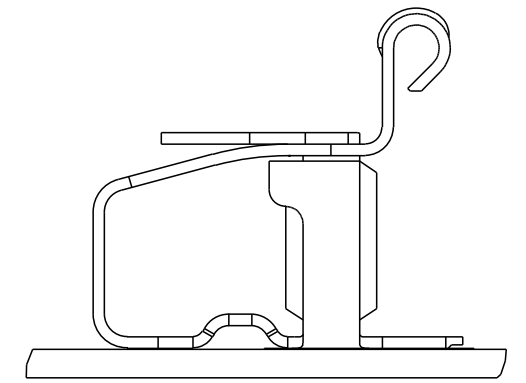
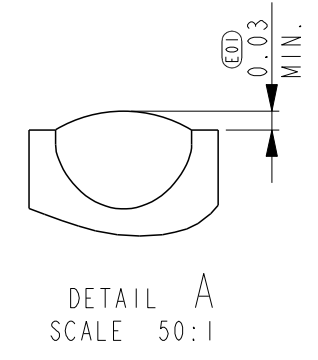
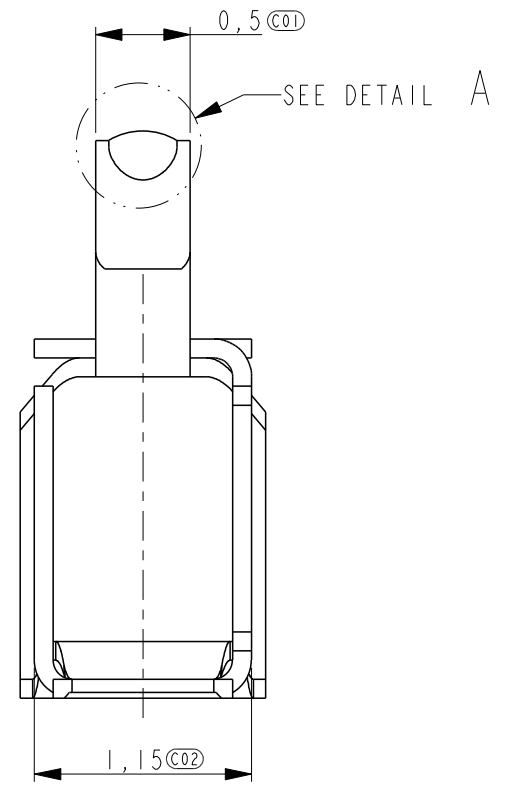
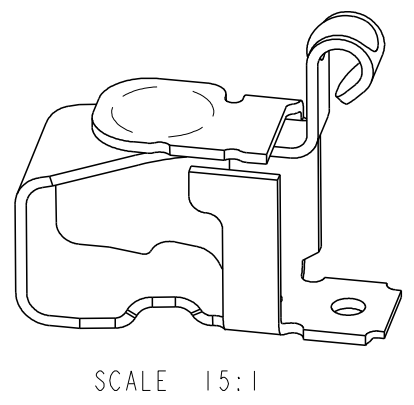
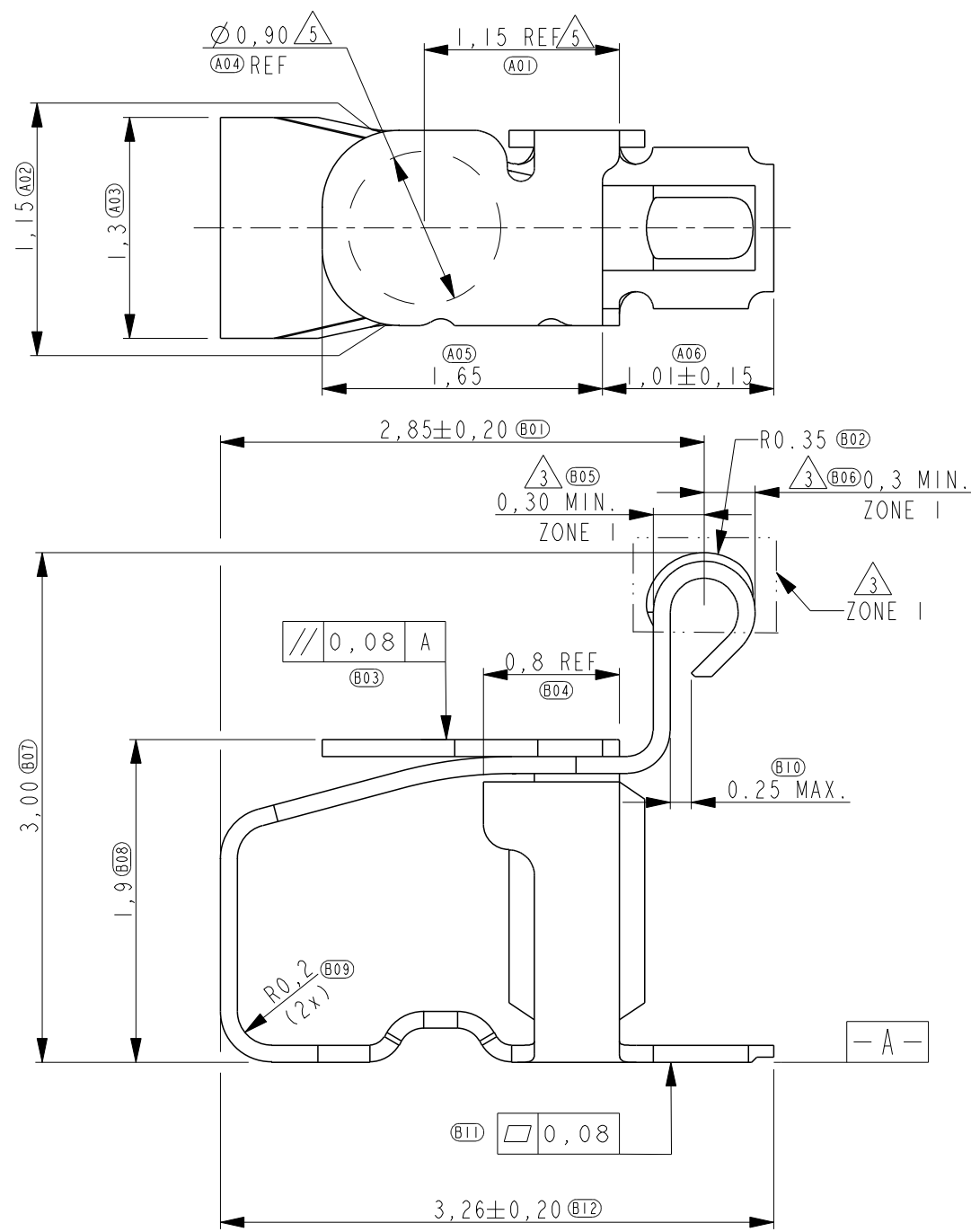

RECOMMENDED PWB LAY-OUT ($\pm 0,05$) DASHED CIRCLES ARE THE LOCATION OF THE SPRING FINGER BOTTOM HOLES

- 1 PART NUMBER: 1551575-5 AS SHOWN.
- 2 MATERIAL: STAINLESS STEEL.
- 3 PLATING: 1,3um MIN. NICKEL UNDERLAYER ALL OVER
ZONE 1: 0,30um MIN. GOLD
ZONE 2: 0,05-0,2um GOLD FLASH
- 4 NORMAL FORCE: $0,6 \pm 0,2$ N AT NOMINAL HEIGHT 2,4MM
- 5 INDICATED SURFACE TO BE USED AS PICK AND PLACE SURFACE.

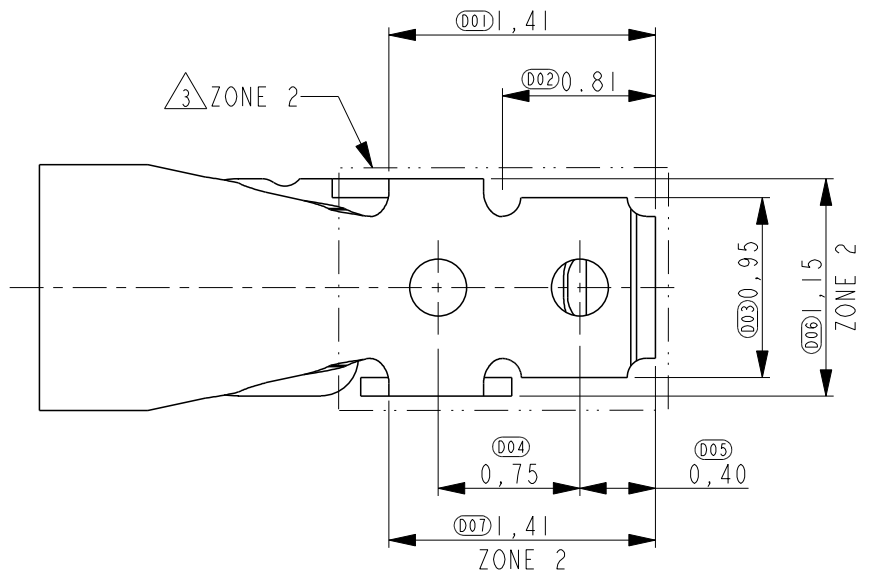

THIS DRAWING IS A CONTROLLED DOCUMENT.		DWN 22JUN2010 Tony Zhang		TE Connectivity	
DIMENSIONS: mm		CHK 22JUN2010 Harada Yohei			
TOLERANCES UNLESS OTHERWISE SPECIFIED:		APVD 22JUN2010 Steven Yao		NAME SPRING FINGER H=3.0mm	
0 PLC $\pm 0,2$		PRODUCT SPEC 108-115008		SIZE	
1 PLC $\pm 0,1$		APPLICATION SPEC		CAGE CODE	
2 PLC $\pm 0,1$		WEIGHT 0.0095		DRAWING NO C=1551575	
3 PLC $\pm 0,05$		CUSTOMER DRAWING		RESTRICTED TO	
4 PLC \pm		SCALE 25:1		SHEET 1 OF 2	
ANGLES $\pm 5^\circ$		REV A1			
FINISH					

THIS DRAWING IS UNPUBLISHED.

RELEASED FOR PUBLICATION

© COPYRIGHT - BY - ALL RIGHTS RESERVED.

LOC ES DIST 00

REVISIONS

P	LTR	DESCRIPTION	DATE	DWN	APVD
-	-	SEE SHEET 1	-	-	-

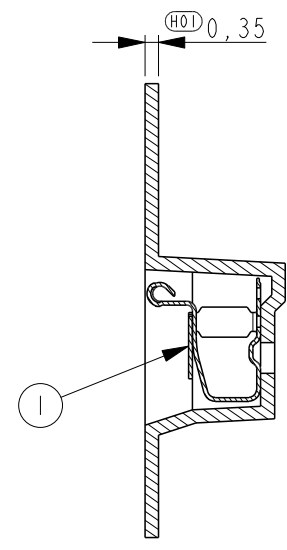
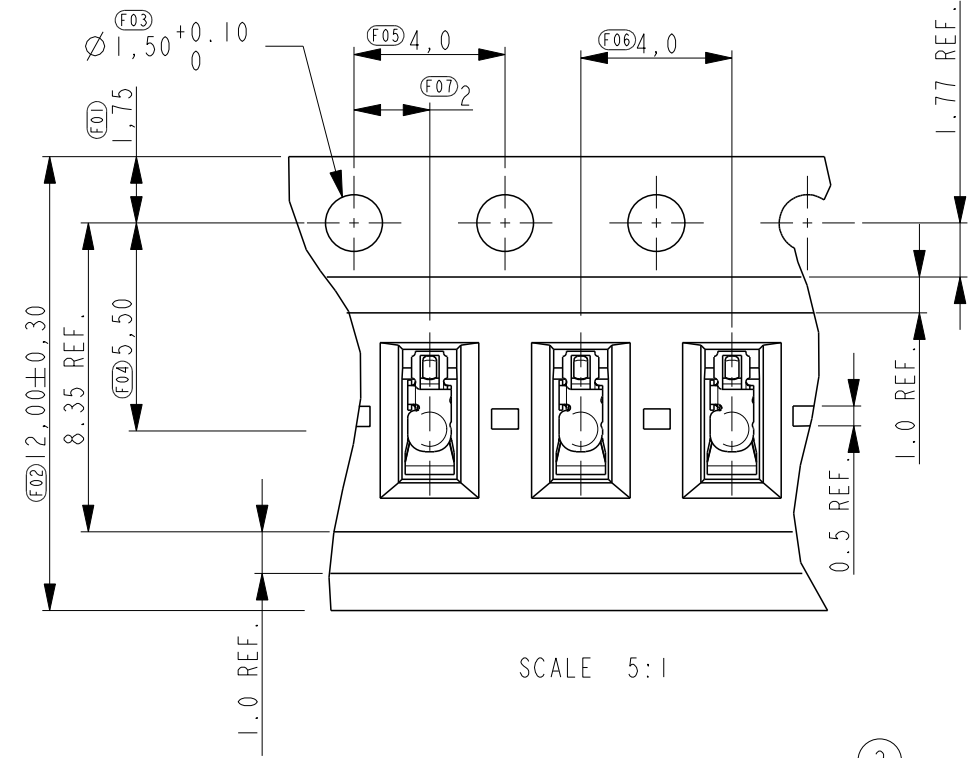

SECTION C-C

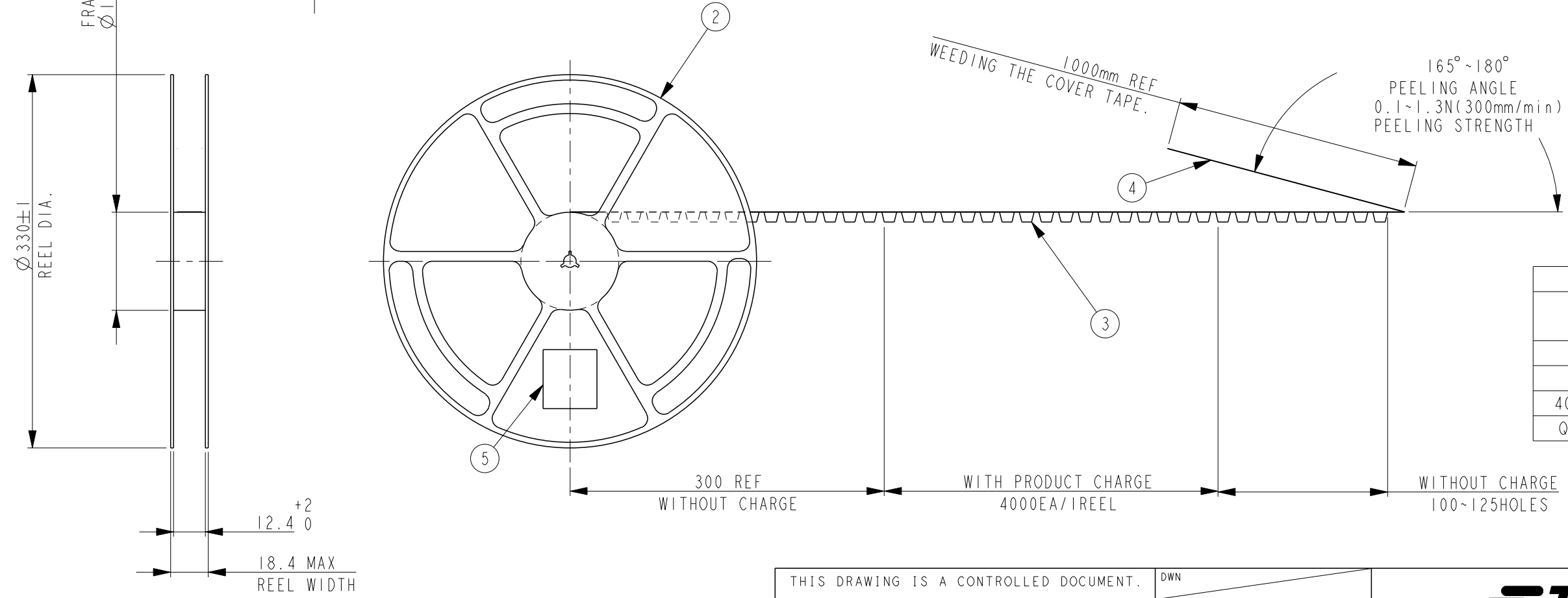

1	LABEL	⑤
1	COVER TAPE (HEAT SEALING)	④
1	EMBOSS	③
1	PLASTIC REEL	②
4000	SPRING FINGER	①
QTY	DESCRIPTION	ITEM

THIS DRAWING IS A CONTROLLED DOCUMENT.		DWN		TE Connectivity	
DIMENSIONS: mm		CHK			
TOLERANCES UNLESS OTHERWISE SPECIFIED:		APVD			
0 PLC ±0.2 1 PLC ±0.1 2 PLC ±0.1 3 PLC ±0.05 4 PLC ANGLES ±5° FINISH -		PRODUCT SPEC			
MATERIAL -		APPLICATION SPEC		NAME	
		WEIGHT		SPRING FINGER H=3.0mm	
		CUSTOMER DRAWING		SIZE A3	CAGE CODE 00779
				DRAWING NO C-1551575	RESTRICTED TO -
				SCALE 25:1	SHEET 2 OF 2
				REV A1	