

REVISIONS					
REV	DATE	DESCRIPTION	BY	CHK	APPV
E1	11MAR11	REVISED PER ECO-11-004587	RK	HMR	
F	24MAY2017	REVISED PER ECO-17-002213	BDA	MM	

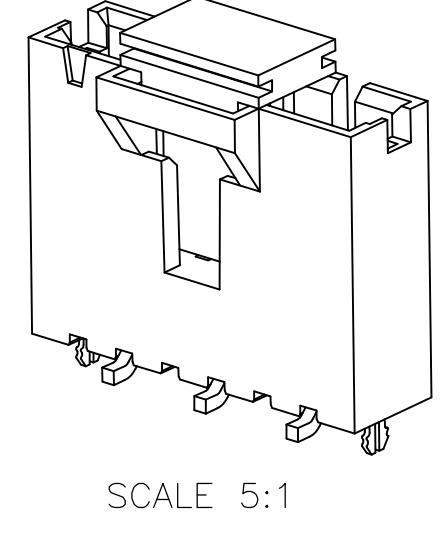
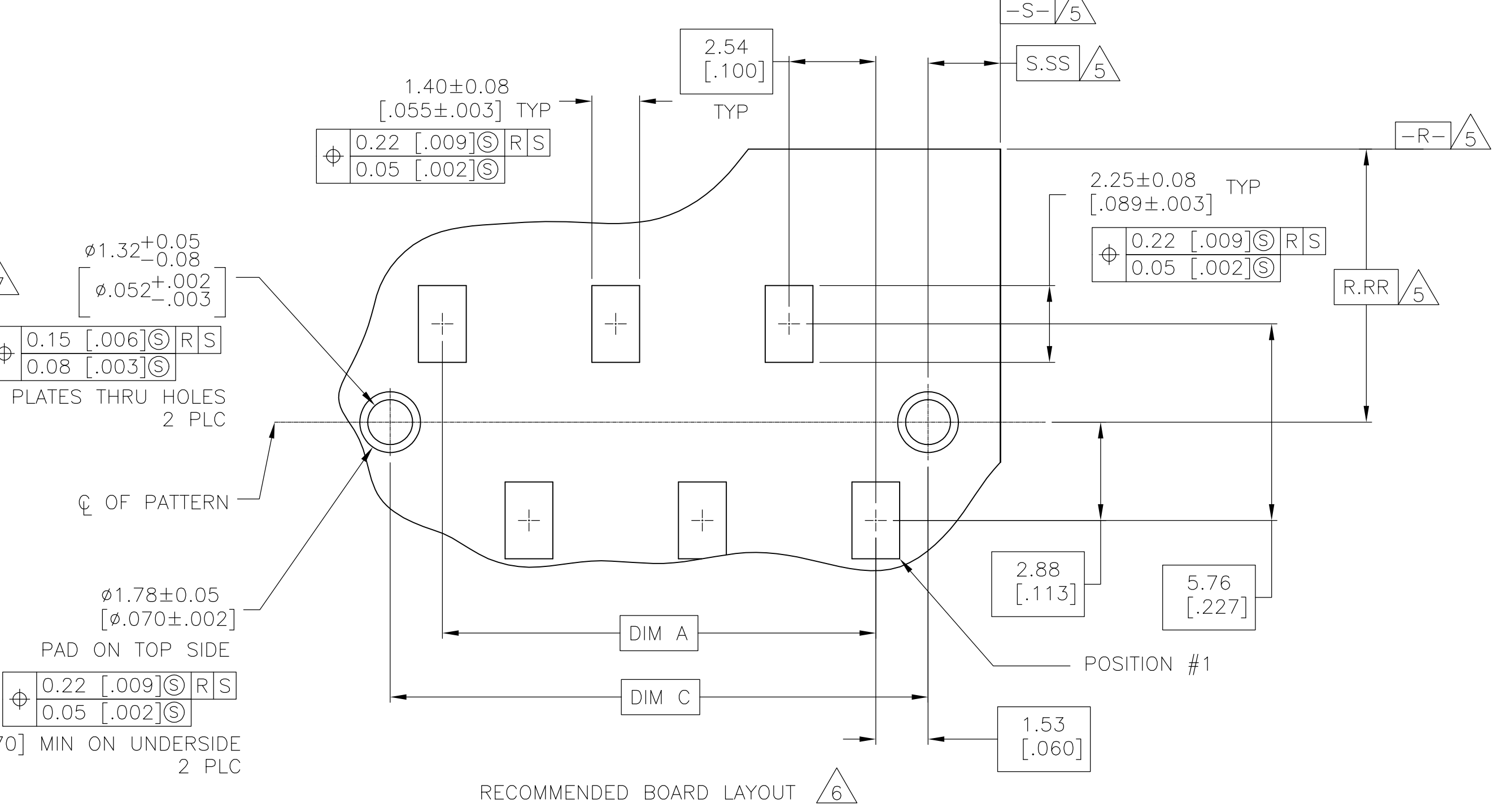
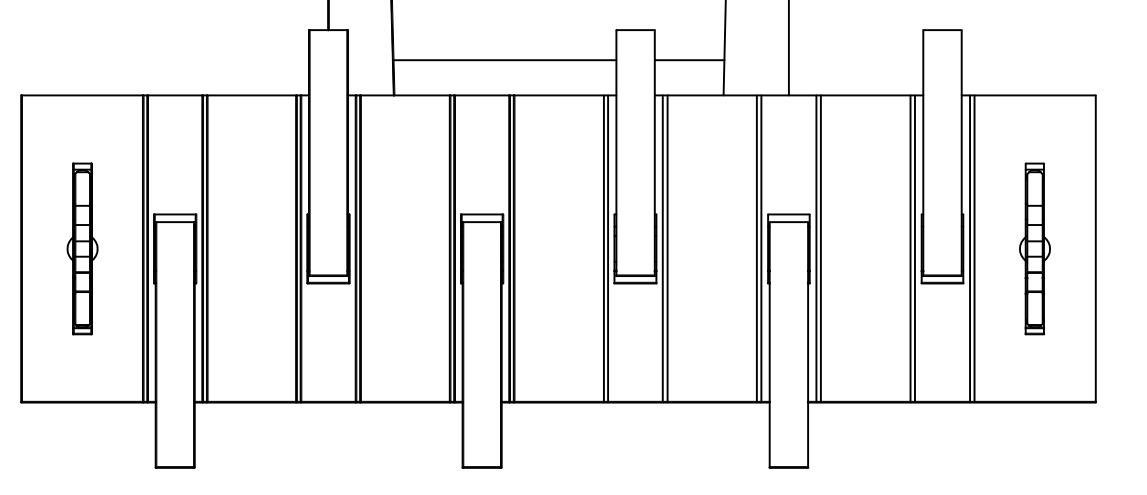
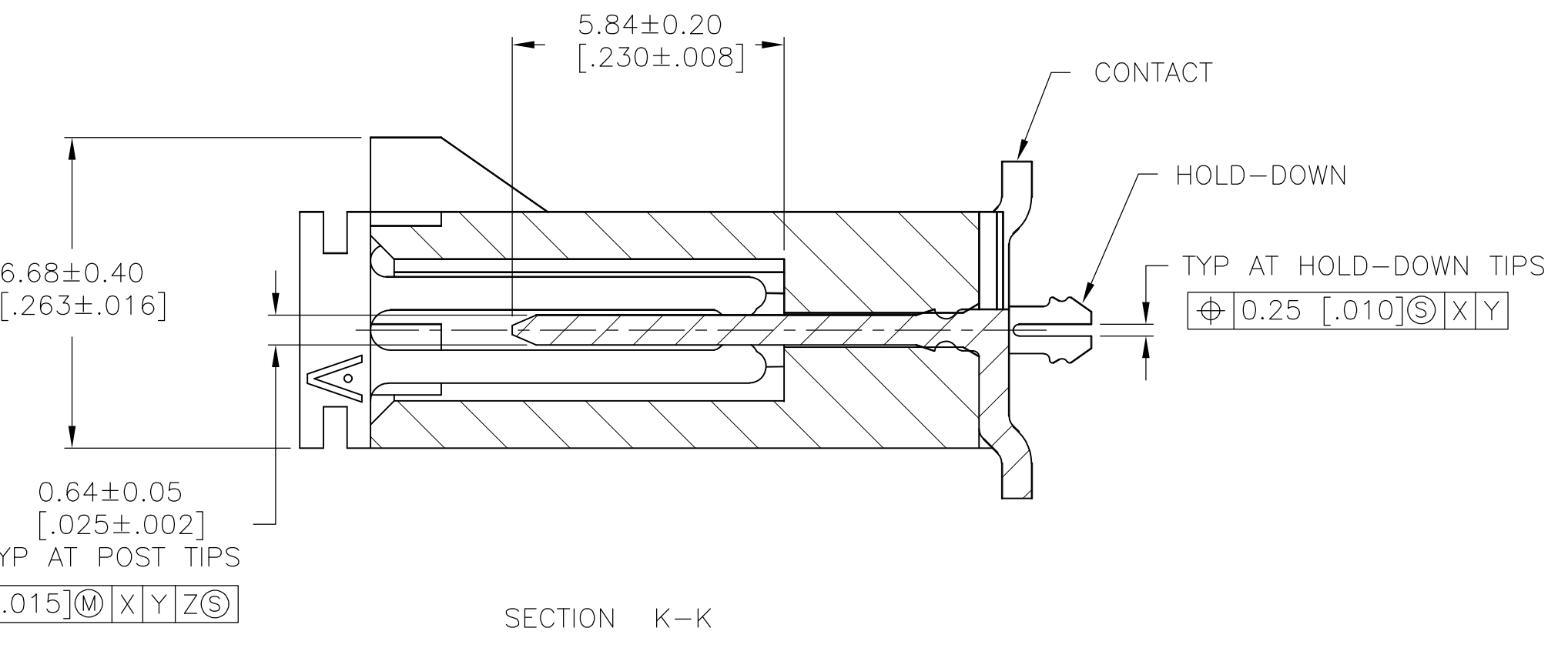
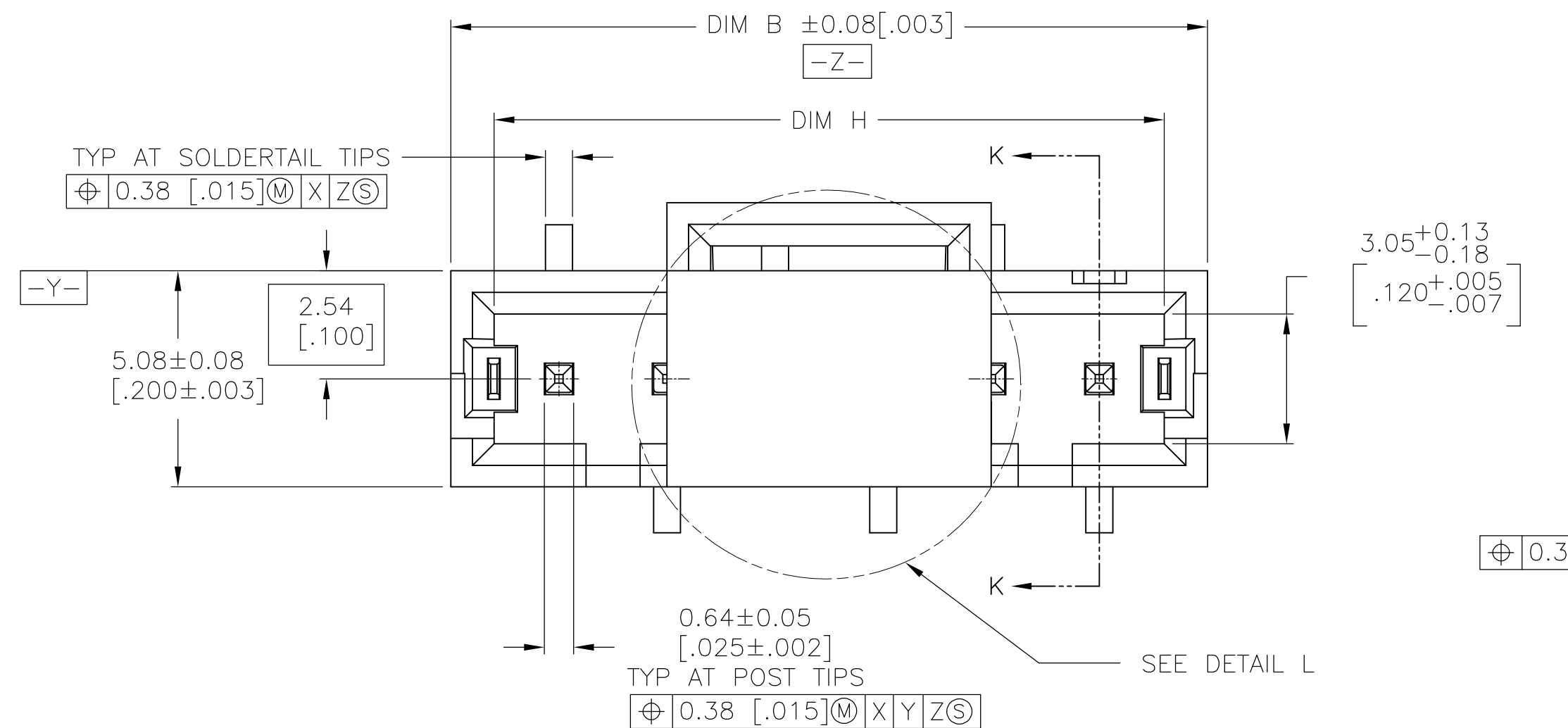
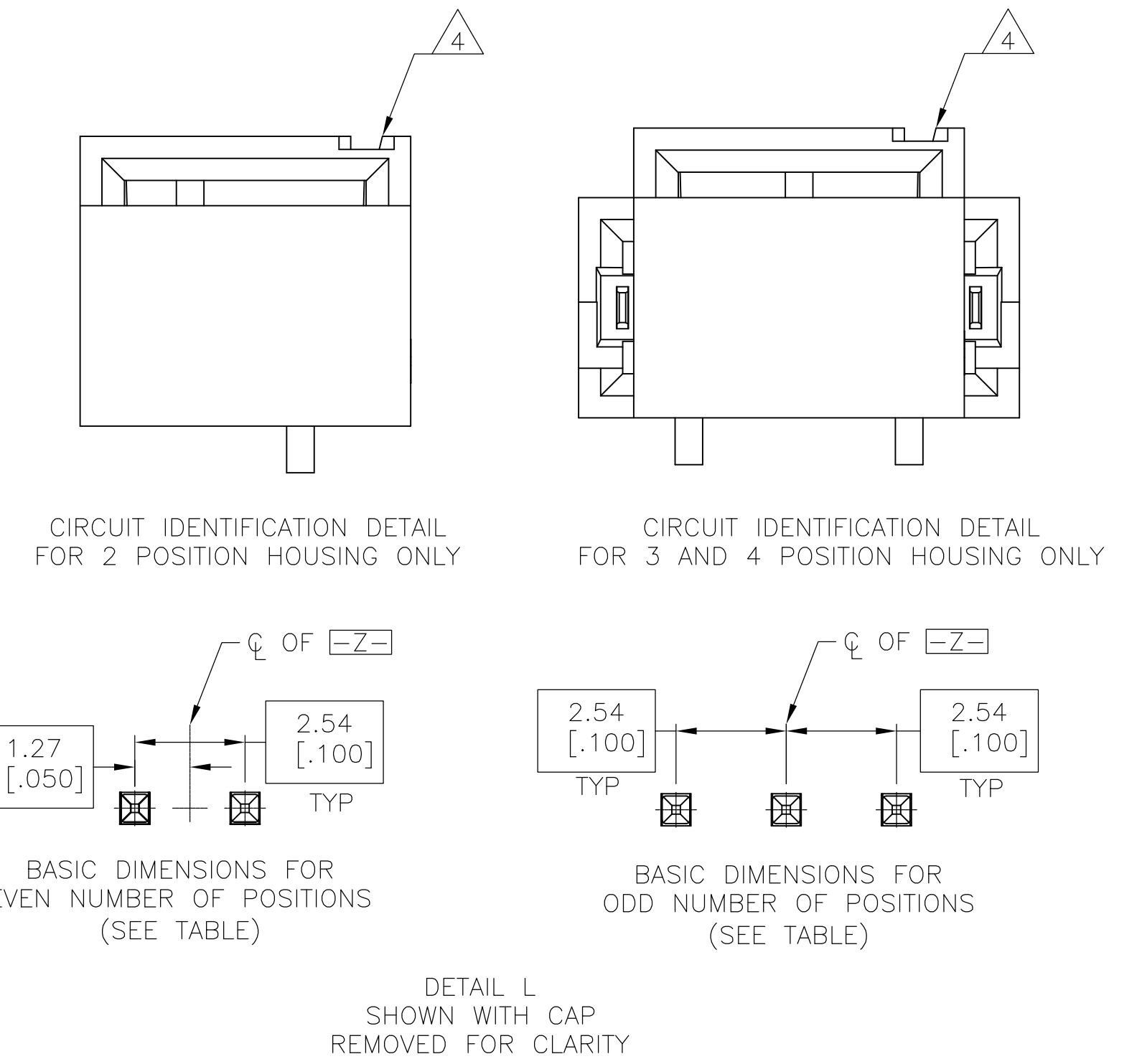
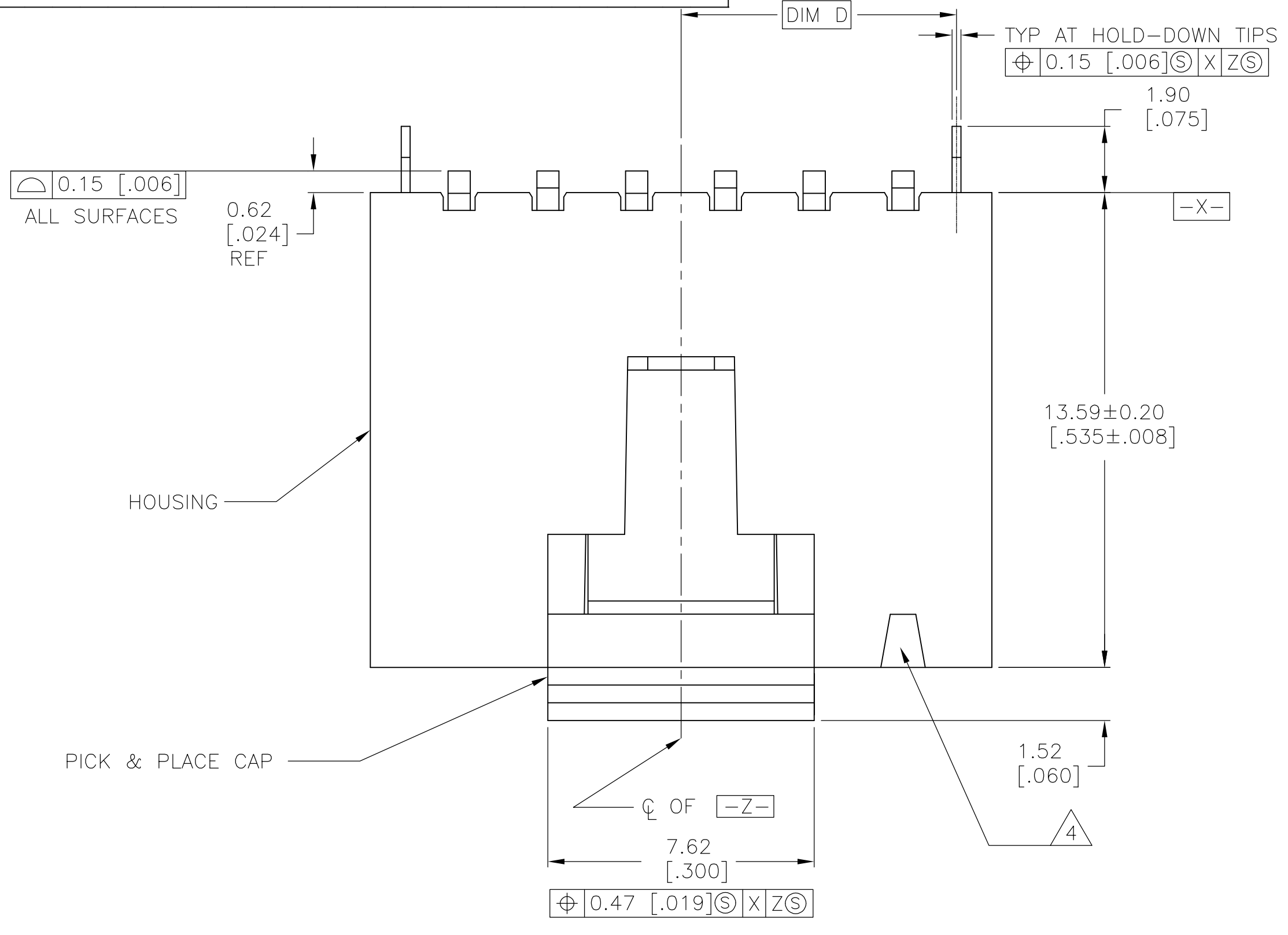

- PACKAGE: TAPE AND REEL PER EIA-481 SPECIFICATIONS. SEE TABLE FOR TAPE WIDTHS
- MATERIAL: HOUSING AND PICK & PLACE CAP: HIGH TEMPERATURE LCP, COLOR - BLACK, CONTACTS: BRASS, HOLD-DOWNS: BERYLLIUM COPPER
- FINISH: CONTACTS: 0.000381 [0.000015] GOLD IN CONTACT AREA, 0.00254 [0.0001] MATTE TIN-LEAD ON SOLDER TAIL ALL OVER 0.00127 [0.00005] NICKEL HOLD-DOWNS: 0.00381 [0.00015] MATTE TIN-LEAD OVER 0.00127 [0.00005] NICKEL
- CIRCUIT POSITION #1 IDENTIFICATION MARK
- DATUMS AND BASIC DIMENSIONS ARE ESTABLISHED BY CUSTOMER
- RECOMMENDED PC BOARD THICKNESS OF 1.57 [0.062]
- USE 1.510 ±0.025 [0.0595±0.010] DRILLED HOLE (#53 DRILL), FINISH TO BE TIN-LEAD OVER 0.02 [0.0008] MIN COPPER
- FINISH: CONTACTS: 0.000381 [0.000015] GOLD IN CONTACT AREA, 0.00254 [0.0001] MATTE TIN ON SOLDER TAIL ALL OVER 0.00127 [0.00005] NICKEL HOLD-DOWNS: 0.00381 [0.00015] MATTE TIN OVER 0.00127 [0.00005] NICKEL

THIS DRAWING IS A CONTROLLED DOCUMENT.		DWG: J. MOSER 260CT99	TE Connectivity	
DIMENSIONS: mm [INCHES]		CHK: L. BRESKOSKY 260CT99	NAME: AMPMODU MTE SURFACE MOUNT. VERTICAL HEADER ASSEMBLY	
TOLERANCES UNLESS OTHERWISE SPECIFIED:		APP'D: K. WRIGHT 27JUN00	PRODUCT SPEC: 108-25034-2	
0 PLC	± -	APPLICATION SPEC: 114-25026		
1 PLC	± -	SIZE: A1		
2 PLC	± 0.13 [0.005]	CAGE CODE: 00779		
3 PLC	± -	DRAWING NO: 1375582		
4 PLC	± -	RESTRICTED TO: -		
ANGLES	± -	CUSTOMER DRAWING		
FINISH: SEE TABLE		SCALE: 8:1 SHEET: 1 OF 2 REV: F		

REVISIONS					
P	LYR	DESCRIPTION	DATE	DWN	APVD
-	-	SEE SHEET 1	-	-	-

△	88	3.465	64.01	2.530	32.01	1.260	64.02	2.520	65.91	2.595	60.96	2.400	25	7-1375582-4
△	88	3.465	61.47	2.420	30.74	1.210	61.48	2.420	63.37	2.495	58.42	2.300	24	7-1375582-3
△	88	3.465	58.93	2.320	29.47	1.160	58.94	2.320	60.83	2.395	55.88	2.200	23	7-1375582-2
△	88	3.465	56.39	2.220	28.20	1.110	56.40	2.220	58.29	2.295	53.34	2.100	22	7-1375582-1
△	88	3.465	53.85	2.120	26.93	1.060	53.86	2.120	55.75	2.195	50.80	2.000	21	7-1375582-0
△	72	2.835	51.31	2.020	25.66	1.010	51.32	2.020	53.21	2.095	48.26	1.900	20	6-1375582-9
△	72	2.835	48.77	1.920	24.39	.960	48.78	1.920	50.67	1.995	45.72	1.800	19	6-1375582-8
△	72	2.835	46.23	1.820	23.12	.910	46.24	1.820	48.13	1.895	43.18	1.700	18	6-1375582-7
△	72	2.835	43.69	1.720	21.85	.860	43.70	1.720	45.59	1.795	40.64	1.600	17	6-1375582-6
△	72	2.835	41.15	1.620	20.58	.810	41.16	1.620	43.05	1.695	38.10	1.500	16	6-1375582-5
△	56	2.205	38.61	1.520	19.31	.760	38.62	1.520	40.51	1.595	35.56	1.400	15	6-1375582-4
△	56	2.205	36.07	1.420	18.04	.710	36.08	1.420	37.97	1.495	33.02	1.300	14	6-1375582-3
△	56	2.205	33.53	1.320	16.77	.660	33.54	1.320	35.43	1.395	30.48	1.200	13	6-1375582-2
△	56	2.205	30.99	1.220	15.50	.610	31.00	1.220	32.89	1.295	27.94	1.100	12	6-1375582-1
△	56	2.205	28.45	1.120	14.23	.560	28.46	1.120	30.35	1.195	25.40	1.000	11	6-1375582-0
△	56	2.205	25.91	1.020	12.96	.510	25.92	1.020	27.81	1.095	22.86	.900	10	5-1375582-9
△	44	1.732	23.37	.920	11.69	.460	23.38	.920	25.27	.995	20.32	.800	9	5-1375582-8
△	44	1.732	20.83	.820	10.42	.410	20.84	.820	22.73	.895	17.78	.700	8	5-1375582-7
△	44	1.732	18.29	.720	9.15	.360	18.30	.720	20.19	.795	15.24	.600	7	5-1375582-6
△	32	1.260	15.75	.620	7.88	.310	15.76	.620	17.65	.695	12.70	.500	6	5-1375582-5
△	32	1.260	13.21	.520	6.61	.260	13.22	.520	15.11	.595	10.16	.400	5	5-1375582-4
△	32	1.260	10.67	.420	5.34	.210	10.68	.420	12.57	.495	7.62	.300	4	5-1375582-3
△	32	1.260	8.13	.320	4.07	.160	8.14	.320	10.03	.395	5.08	.200	3	5-1375582-2
△	24	.945	5.59	.220	2.80	.110	5.60	.220	7.49	.295	2.54	.100	2	5-1375582-1
△	88	3.465	64.01	2.530	32.01	1.260	64.02	2.520	65.91	2.595	60.96	2.400	25	2-1375582-4
△	88	3.465	61.47	2.420	30.74	1.210	61.48	2.420	63.37	2.495	58.42	2.300	24	2-1375582-3
△	88	3.465	58.93	2.320	29.47	1.160	58.94	2.320	60.83	2.395	55.88	2.200	23	2-1375582-2
△	88	3.465	56.39	2.220	28.20	1.110	56.40	2.220	58.29	2.295	53.34	2.100	22	2-1375582-1
△	88	3.465	53.85	2.120	26.93	1.060	53.86	2.120	55.75	2.195	50.80	2.000	21	2-1375582-0
△	72	2.835	51.31	2.020	25.66	1.010	51.32	2.020	53.21	2.095	48.26	1.900	20	1-1375582-9
△	72	2.835	48.77	1.920	24.39	.960	48.78	1.920	50.67	1.995	45.72	1.800	19	1-1375582-8
△	72	2.835	46.23	1.820	23.12	.910	46.24	1.820	48.13	1.895	43.18	1.700	18	1-1375582-7
△	72	2.835	43.69	1.720	21.85	.860	43.70	1.720	45.59	1.795	40.64	1.600	17	1-1375582-6
△	72	2.835	41.15	1.620	20.58	.810	41.16	1.620	43.05	1.695	38.10	1.500	16	1-1375582-5
△	56	2.205	38.61	1.520	19.31	.760	38.62	1.520	40.51	1.595	35.56	1.400	15	1-1375582-4
△	56	2.205	36.07	1.420	18.04	.710	36.08	1.420	37.97	1.495	33.02	1.300	14	1-1375582-3
△	56	2.205	33.53	1.320	16.77	.660	33.54	1.320	35.43	1.395	30.48	1.200	13	1-1375582-2
△	56	2.205	30.99	1.220	15.50	.610	31.00	1.220	32.89	1.295	27.94	1.100	12	1-1375582-1
△	56	2.205	28.45	1.120	14.23	.560	28.46	1.120	30.35	1.195	25.40	1.000	11	1-1375582-0
△	56	2.205	25.91	1.020	12.96	.510	25.92	1.020	27.81	1.095	22.86	.900	10	1375582-9
△	44	1.732	23.37	.920	11.69	.460	23.38	.920	25.27	.995	20.32	.800	9	1375582-8
△	44	1.732	20.83	.820	10.42	.410	20.84	.820	22.73	.895	17.78	.700	8	1375582-7
△	44	1.732	18.29	.720	9.15	.360	18.30	.720	20.19	.795	15.24	.600	7	1375582-6
△	32	1.260	15.75	.620	7.88	.310	15.76	.620	17.65	.695	12.70	.500	6	1375582-5
△	32	1.260	13.21	.520	6.61	.260	13.22	.520	15.11	.595	10.16	.400	5	1375582-4
△	32	1.260	10.67	.420	5.34	.210	10.68	.420	12.57	.495	7.62	.300	4	1375582-3
△	32	1.260	8.13	.320	4.07	.160	8.14	.320	10.03	.395	5.08	.200	3	1375582-2
△	24	.945	5.59	.220	2.80	.110	5.60	.220	7.49	.295	2.54	.100	2	1375582-1

PLATING	TAPE WIDTH	H	D	C	B	A	NO OF POSN	PART NUMBER

THIS DRAWING IS A CONTROLLED DOCUMENT.		DIN J. MOSER 260CT99	 TE Connectivity
TOLERANCES UNLESS OTHERWISE SPECIFIED:		CJK L. BRESKOSKY 260CT99 APVD K. WRIGHT 27JUN00 NAME	
DIMENSIONS: mm [INCHES]	0. PLC ± - 1. PLC ± - 2. PLC ± 0.13 [0.005] 3. PLC ± - 4. PLC ± - ANGLES ± -	PRODUCT SPEC 108-25034-2	AMPMODU MTE SURFACE MOUNT. VERTICAL HEADER ASSEMBLY
MATERIAL	FINISH SEE TABLE	APPLICATION SPEC 114-25026	SIZE CASE CODE DRAWING NO A1 00779 C=1375582
		WEIGHT	RESTRICTED TO
		CUSTOMER DRAWING	SCALE 8:1 SHEET 2 OF 2 REV F