

THIS DRAWING IS UNPUBLISHED. RELEASED FOR PUBLICATION
 © COPYRIGHT - By - ALL RIGHTS RESERVED.

LOC		DIST		REVISIONS			
P	LTR	DESCRIPTION		DATE	DWN	APVD	
AA	00	E2	REVISED PER ECO-11-005033	26MAR11	RK	HMR	

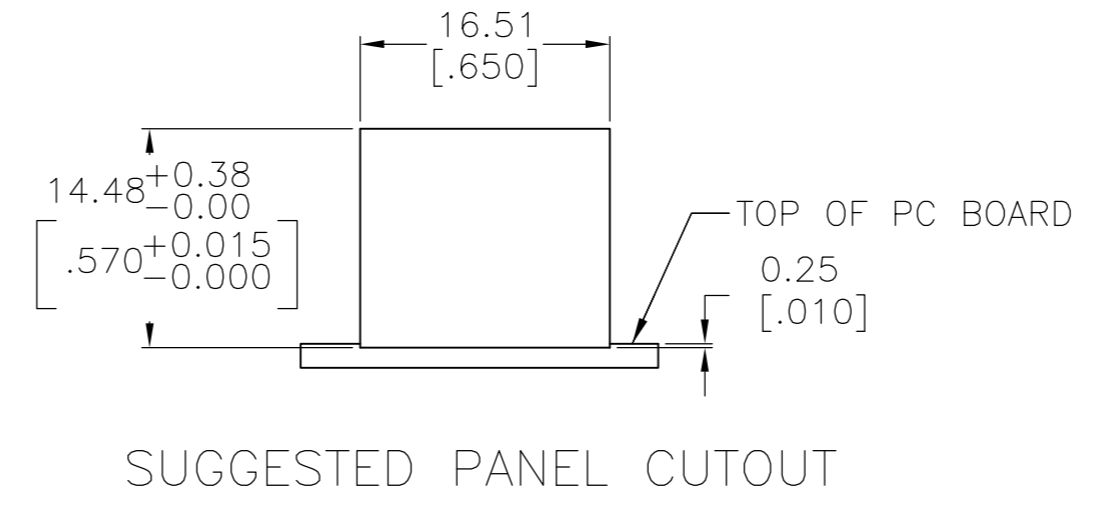
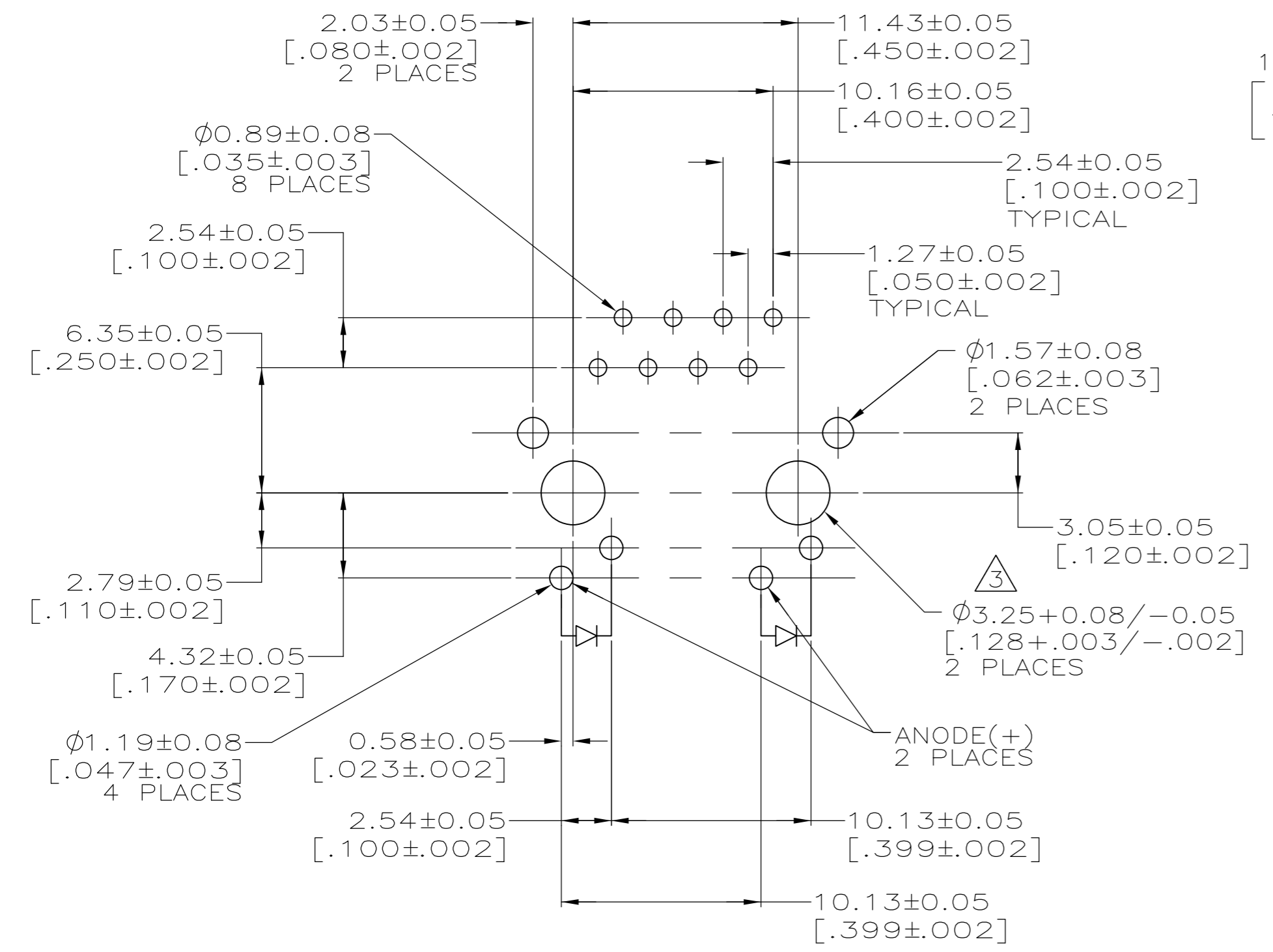
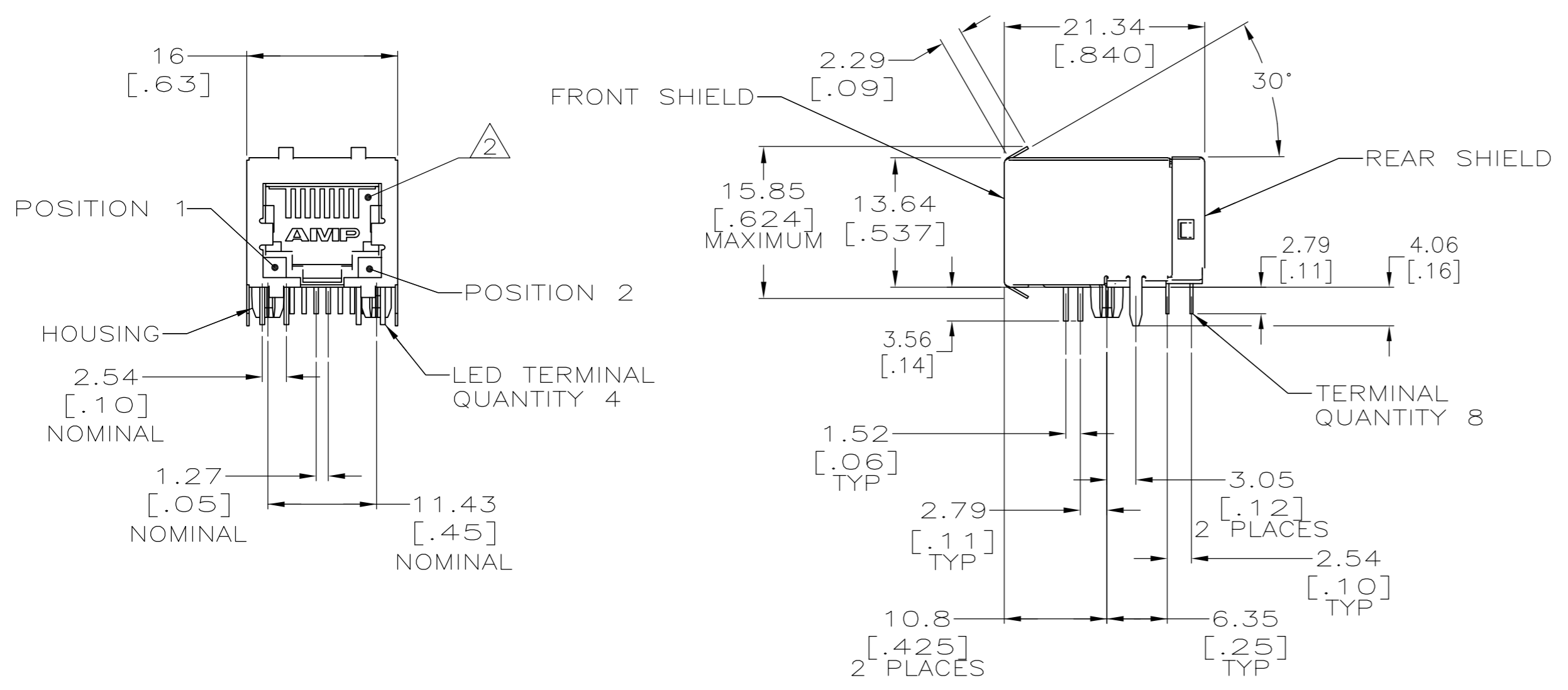

- MATERIAL: HOUSING - PBT THERMOPLASTIC BLACK, UL94V-0.
 TERMINALS - 0.33[.013] THICK PHOS BRONZE PLATED WITH 1.27µm[.000050] MINIMUM THICK HARD GOLD IN LOCALIZED AREA AND 3.81µm[.000150] MINIMUM THICK MATTE TIN IN SOLDER AREA OVER 1.27µm[.000050] MINIMUM THICK NICKEL UNDERPLATE.
 SHIELDS - 0.25 [.010] THICK COPPER ALLOY PLATED WITH 1.27µm[.000050] MINIMUM NICKEL AND 2.03 µm[.000080] MINIMUM HOT TIN DIP ON PCB GROUND TABS.
 LIGHT EMITTING DIODE (LED) - DIFFUSED EPOXY LENS, 0.51 x 0.51[.020 x .020] CARBON STEEL WIREFRAME LEADS PREPLATED WITH 8.89 µm[.0003500] THICK Sn/Cu OVER 2.03 µm[.000080] THICK Ag OVER 1.02µm[.000040] THICK Cu OVER 3.56 µm[.000140] THICK Ni OVER 1.02µm[.000040] Cu UNDERPLATE
- JACK CAVITY CONFORMS TO FCC RULES AND REGULATIONS, PART 68 SUBPART F.
- USE #30 DRILL BIT OR 3.25mm DRILL BIT WHEN PRODUCING THESE PCB HOLES.
- THIS MODULAR JACK WITH INTEGRATED LEDS IS NOT IR REFLOW SOLDERING PROCESS COMPATIBLE.

SUGGESTED PC BOARD LAYOUT
 COMPONENT SIDE
 SCALE 4:1

1	YELLOW	GREEN	5569564-5
1	GREEN	GREEN	5569564-4
1	GREEN	YELLOW	5569564-1
MATERIAL	POSITION 1	POSITION 2	PART NUMBER
	LED COLOR		

THIS DRAWING IS A CONTROLLED DOCUMENT.		DWN L. VARELA - DOCK5 07JUN2005	TE Connectivity	
DIMENSIONS: mm [INCHES]		CHK J. WESTMAN 07JUN2005	NAME	
TOLERANCES UNLESS OTHERWISE SPECIFIED:		APVD S. FLICKINGER 07JUN2005	MODULAR JACK ASSEMBLY, 8 POSITION, RIGHT ANGLE, LOW PROFILE, PANEL GROUND WITH LEDS	
0 PLC ± -	1 PLC ± -	PRODUCT SPEC 108-1163	SIZE A2	CAGE CODE 00779
2 PLC ± 0.25[.01]	3 PLC ± 0.13[.005]	APPLICATION SPEC 114-2154	DRAWING NO C=5569564	RESTRICTED TO -
4 PLC ± -	ANGLES ± -	WEIGHT -	SCALE 2:1	SHEET 1 of 1
MATERIAL	FINISH	CUSTOMER DRAWING	REV E2	

Mouser Electronics

Authorized Distributor

Click to View Pricing, Inventory, Delivery & Lifecycle Information:

[TE Connectivity:](#)

[5569564-1](#)