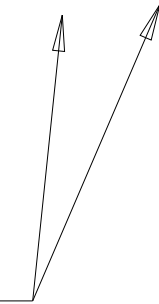

THIS DRAWING IS UNPUBLISHED. RELEASED FOR PUBLICATION 20
 © COPYRIGHT 20 BY - ALL RIGHTS RESERVED.

LOC	DIST	REVISIONS					
		P	LTR	DESCRIPTION	DATE	DWN	APVD
HQ	00		E3	REVISED PER ECO-12-0016455	12SEP2012	DW	GG
			F	REVISED PER ECO-20-004473	27MAR2020	SJ	JH

OBSOLETE

 94V-0
XXXX XXXXX

4 DIGIT DATE CODE
AND
TE CONNECTIVITY VENDOR
SOURCE CODE

LOOSE PIECE ANTENNA
P/N 1513259-1 AS SHOWN

SUPERSEDED BY:
2108788-1 OR -2

NOTES: UNLESS OTHERWISE SPECIFIED.

- FABRICATE TO MEET IPC - 6012, CLASS 2.
INSPECT TO MEET IPC - A - 600, CLASS 2.
- PRIMARY AND SECONDARY SIDES SHOWN.
- MATERIAL: GETEK 8 PLY (7628) 1.49JTHK.
GRADE RG200D 1/2 OZ. COPPER BOTH SIDES.
DIELECTRIC CONSTANT @ 1MHZ 4.2±0.1.
- FINISH:
A: 1/2 Oz COPPER PLATING
B: SOLDERMASK OVER BARE COPPER (SMOBC).
C: MASK BOTH SIDES OF PCB WITH LPI SOLDERMASK.
SOLDERMASK COLOR: NATURAL GREEN.
D: TOP AND BOTTOM OF PABS E.N.I.G PLATING
- TWO PLACE TOLERANCES: ± 0.23
- PACKAGING: SINGULATED PARTS TO BE SECURELY SHRINK
WRAPPED, BAGGED OR VACUUM PACKED IN BULK.
FOR TAPE AND REEL SEE SHEET 2
- PARTS ARE COMPLIANT TO ROHS STANDARDS PER
TE CONNECTIVITY STANDARD TEC-138-702.
- CONSULT TE CONNECTIVITY DATA SHEET DSI513259
- CONTACT TE CONNECTIVITY ENGINEERING
PRIOR TO DESIGNING INTO AN APPLICATION

FOR BULK PACKAGING, ORDER P/N 1513259-1
FOR TAPE & REEL PACKAGING, ORDER P/N 1513259-9

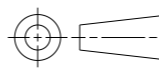
THIS DRAWING IS A CONTROLLED DOCUMENT.		DWN DJI	13MAR2007	 TE Connectivity	
DIMENSIONS: mm		CHK	-		
		TOLERANCES UNLESS OTHERWISE SPECIFIED:		NAME World GSM Antenna	
		0 PLC ±-	1 PLC ±-	APVD	-
MATERIAL		2 PLC ±-	3 PLC ±-	PRODUCT SPEC	
FINISH		4 PLC ±-	ANGLES ±-	APPLICATION SPEC	
				SIZE	A3
				CAGE CODE	00779
				DRAWING NO	C-1513259
				RESTRICTED TO	
				WEIGHT	-
				CUSTOMER DRAWING	
				SCALE	2:1
				SHEET	1 OF 2
				REV	F

THIS DRAWING IS UNPUBLISHED. RELEASED FOR PUBLICATION 20
 © COPYRIGHT 20 BY - ALL RIGHTS RESERVED.

LOC	DIST	REVISIONS			
P	LTR	DESCRIPTION	DATE	DWN	APVD
		SEE SHEET 1	-	-	-

1513259-9 AS SHOWN

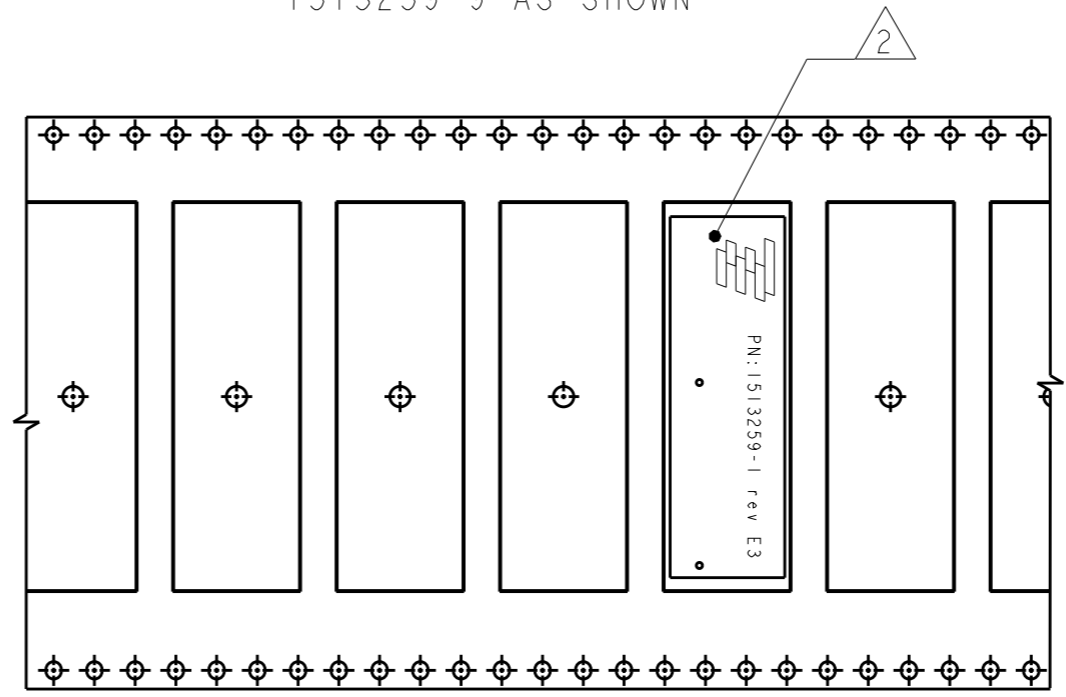

UNREELING DIRECTION

NOTES: UNLESS OTHERWISE SPECIFIED.

1. REFER TO TE CONNECTIVITY DRAWING NO. C-1533293 (PN: 1533293-7) FOR PACKAGING CONTROLLED DOCUMENT SPECIFICATION.

2 ORIENT PARTS AS SHOWN.

3. PARTS ARE COMPLIANT TO RoHS STANDARDS PER TE CONNECTIVITY STANDARD TEC-138-702

4. ALL INFORMATION ON THIS DRAWING IS CONFIDENTIAL AND PROPRIETARY TO TE CONNECTIVITY.

THIS DRAWING IS A CONTROLLED DOCUMENT.		DWN DJL 13MAR2007		
DIMENSIONS: mm		CHK -		
TOLERANCES UNLESS OTHERWISE SPECIFIED:		APVD -	NAME World GSM Antenna	
0 PLC ±-		PRODUCT SPEC -	SIZE CAGE CODE DRAWING NO RESTRICTED TO	
1 PLC ±-		APPLICATION SPEC -	A300779 C-1513259	
2 PLC ±-		WEIGHT -	SCALE 2:1 SHEET 2 OF 2 REV F	
3 PLC ±-		CUSTOMER DRAWING		
4 PLC ±-				
ANGLES ±-				
MATERIAL - FINISH -				