

©1969 BY AMP INCORPORATED. ALL RIGHTS RESERVED. AMP PRODUCTS COVERED BY PATENTS AND/OR PATENTS PENDING.

THIS PRODUCT DESIGNED AND BUILT BY AMP INCORPORATED. NO LICENSE TO USE THAT DESIGN IN MANUFACTURE, OR TO USE ANY ISSUED OR PENDING PATENTS WHICH ARE INVOLVED, IS IMPLIED.

REVISIONS				
ZONE	LTR	DESCRIPTION	DATE	APPROVED
	A	REV. NOTE 1	LAB 10-15-73	LPA
	B	REVISED	DS 10-13-76	M.S.
	C	REV. PER E.C.N. 8691	AG 3-5-79	M.S.
	D	OBSOLETE - 2 ECN 53622	11-13-86	R.S.
	E	REVISED PER ECN S-3960	4-10-87	R.S.
	F	REV PER OH14-0192-05	1-06	PY
	G	REV PER ECO-12-009412	PY 6-21-12	DE

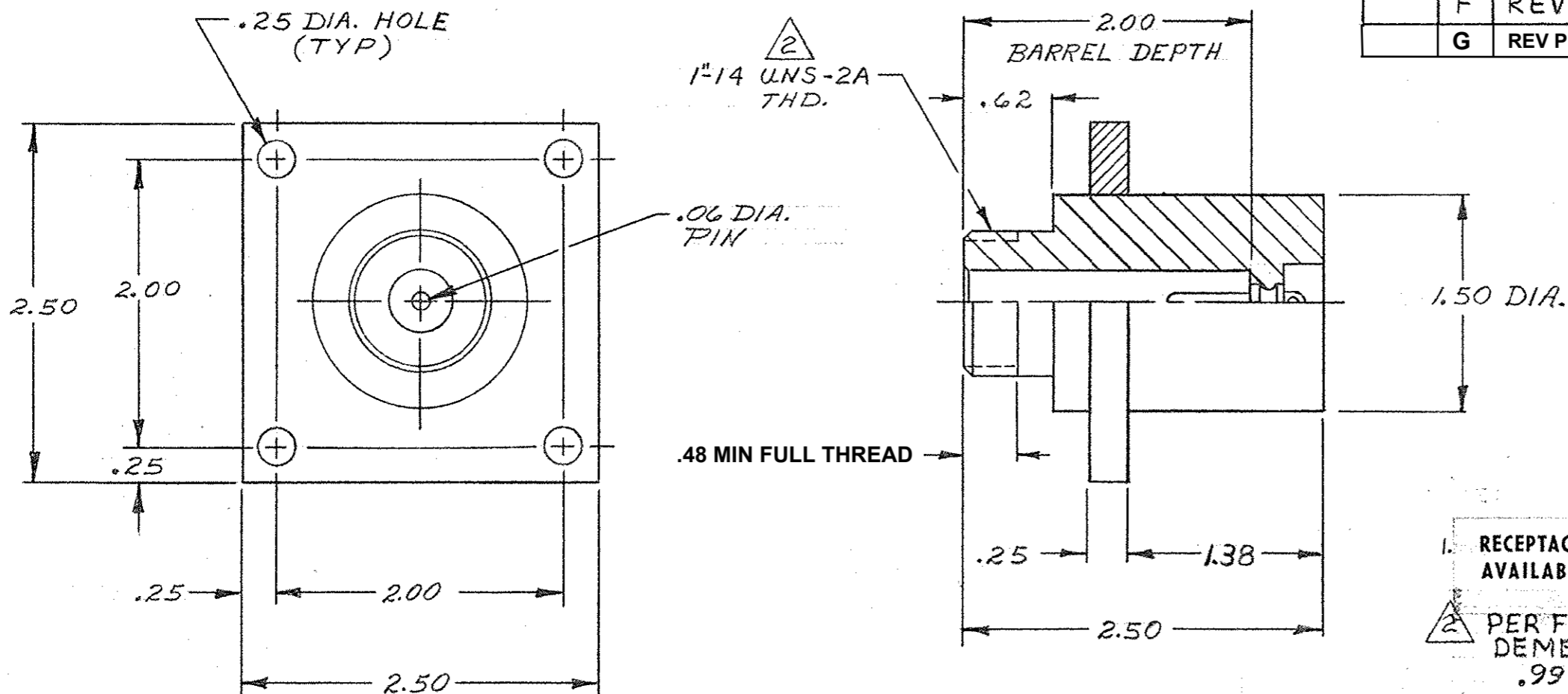

1. RECEPTACLE TO MATE WITH AMP LGH-4 LEAD ASSEMBLY, AVAILABLE SEPARATELY.

2. PER FEDERAL STANDARD H-28 3 WIRE METHOD. DIMENSION OVER WIRES TO BE: .9975 - 1.0186.

	5-850912-1	AS SHOWN WITH TIN PLATED PIN
OBSOLETE	850912-2	AS SHOWN WITH GOLD PLATED PIN
	850912-1	AS SHOWN WITH TIN-LEAD PLATED PIN

ITEM NO.	DWG SIZE	PART OR IDENTIFYING NO.	NOMENCLATURE OR DESCRIPTION	SYMBOL
----------	----------	-------------------------	-----------------------------	--------

PARTS LIST

UNLESS OTHERWISE SPECIFIED: DIMENSIONS ARE IN INCHES				CONTRACT NO.		AMP INCORPORATED	
TOLERANCES				DR <i>L. Witt</i> 6-11-69		CAPITRON DIVISION	
.00 ± .04 ANGLES				CHK		ELIZABETHTOWN, PENNSYLVANIA	
.000 ± .015				APPD		NAME	
MATERIAL: MOLDED GLASS EPOXY				APPD		LGH-4 FLANGED RECEPTACLE ASS'Y	
FINISH: BLACK				DSGN APPD <i>S. Wilson</i> 6-12-69		RECESSED TERMINAL MOUNT	
NEXT ASSY				OTHER APPD		(FOR BULKHEAD APPLICATION)	
FINAL ASSY				SIZE B		CODE IDENT NO. 00779	
NEXT ASSY				NUMBER 850912		REV G	
USED ON				SCALE <i>H</i>		WT	
QTY REQD				SHEET 1 OF 1			
APPLICATION							

PRINT DIST L 37

# Mouser Electronics

Authorized Distributor

Click to View Pricing, Inventory, Delivery & Lifecycle Information:

[TE Connectivity:](#)

[5-850912-1](#)