

QUICK START GUIDE FOR DEMONSTRATION CIRCUIT 432

HIGH EFFICIENCY SYNCHRONOUS STEP-DOWN REGULATOR

LTC1875 or LTC1879

DESCRIPTION

Demonstration circuit 432 is a step-down converter, featuring either the LTC1875 or LTC1879 high frequency monolithic switching regulators. With an input voltage range from 2.65V to 6V, the LTC1875 is ideal for Li-Ion applications, such as PDAs, cellular phones, and digital cameras. For applications with higher input voltages, the LTC1879 is the choice with its maximum input voltage limit of 10V. Both devices have switch current limits over 1A (LTC1875-1.6A, LTC1879-1.8A), which allows these

ICs to deliver high(er) power to small, low-profile applications. While the standard operating frequency of both parts is 550 kHz, the switching can be externally set as high as 750 kHz. All these features make the LTC1879 (DC432A) or LTC1875 (DC432B) perfectly suited for battery-powered, surface mount applications.

Design files for this circuit board are available. Call the LTC factory.

Table 1. Performance Summary

PARAMETER	CONDITION	VALUE
Minimum Input Voltage		2.65V
Maximum Input Voltage (LTC1875) Maximum Input Voltage (LTC1879)		6V 10V
V_{OUT} (LTC1875) V_{OUT} (LTC1879)	$I_{OUT} = 0A$ to 1.5A $I_{OUT} = 0A$ to 1.2A	$0.8V \pm 2\%$ to $V_{IN} \pm 2\%$ $0.8V \pm 2\%$ to $V_{IN} \pm 2\%$
I_{OUT} (LTC1875) I_{OUT} (LTC1879)		1.5A 1.2A
Nominal Switching Frequency		550kHz

QUICK START PROCEDURE

Demonstration circuit 432 is easy to set up to evaluate the performance of the LTC1875 or LTC1879. Refer to Figure 1 for proper measurement equipment setup and follow the procedure below:

When measuring the input or output voltage ripple, care must be taken to avoid a long ground lead on the oscilloscope probe. Measure the input or output voltage ripple by touching the probe tip directly across the Vin or Vout and GND terminals. Refer to Figure 2 for proper placement of the scope probe.

1. Place jumper JP2 in the SHDN position.
2. Select the desired output voltage, using jumper JP3. The fixed output options are 1.8V, 2.5V, and 3.3V. To set the output voltage to a custom value, insert a resistor into RFB5.

3. Connect the load between the Vout and GND terminals on the bottom right-side of the board.
4. With power off, connect the input power supply to Vin and GND (which are at the bottom left-side of the board). Turn on the power at the input.

NOTE: If evaluating the LTC1875, do not exceed 6V input; if evaluating the LTC1879, do not exceed 10V in.

5. Place jumper JP2 in the RUN position.
6. Check for the proper output voltages.
If there is no output, temporarily disconnect the load to make sure that the load is not set too high.
7. Once the proper output voltages are established, adjust the loads within the operating range and observe the output voltage regulation, ripple voltage, efficiency and other parameters.

QUICK START GUIDE FOR DEMONSTRATION CIRCUIT 432 HIGH EFFICIENCY SYNCHRONOUS STEP-DOWN REGULATOR

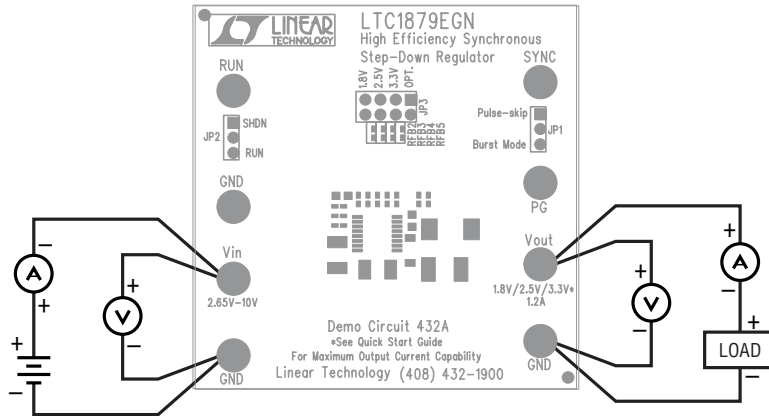

Figure 1. Proper Measurement Equipment Setup for both versions of the board: LTC1879 (DC432A) and LTC1875 (DC432B)

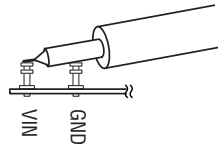
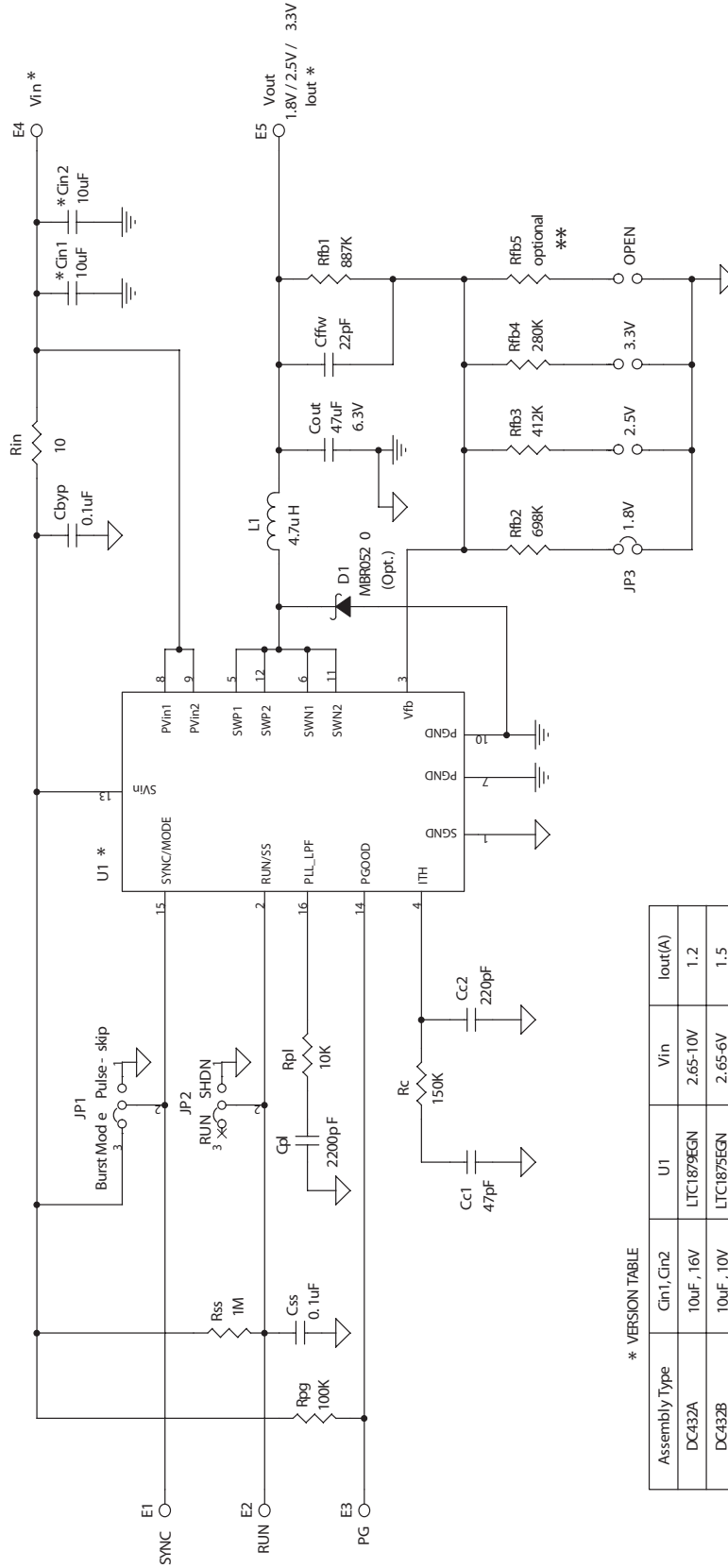

Figure 2. Scope Probe Placement for Measuring Input or Output Ripple

QUICK START GUIDE FOR DEMONSTRATION CIRCUIT 432

HIGH EFFICIENCY SYNCHRONOUS STEP-DOWN REGULATOR



* VERSION TABLE

Assembly Type	Cin1, Cin2	U1	Vin	Iout(A)
DC432A	10μF, 16V	LTC1875EGN	2.65-10V	1.2
DC432B	10μF, 10V	LTC1875EGN	2.65-6V	1.5

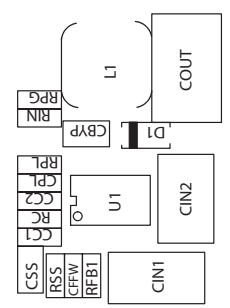

PCB SILKSCREEN

** Space Provided for an Optional Resistor to Program a Custom Output Voltage

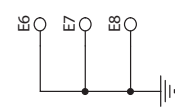

Item	Qty	Reference	Part Description	Manufacture / Part #
1	2	Cbyp,Css	CAP., X7R, 0.1uF, 16V, 20% 0603	AVX, 0603YC104MAT
2	1	Cc1	CAP., NPO, 47pF, 50V, 10% 0402	AVX, 04025A470KAT
3	1	Cc2	CAP., X7R, 220pF, 50V, 20% 0402	AVX, 04025C221MAT
4	1	Cffw	CAP., NPO, 22pF, 50V, 10% 0402	AVX, 04025A220KAT
5	2	Cin1,Cin2	CAP., X5R, 10uF, 16V, 20% 1210	TAIYO YUDEN, EMK325BJ106MN
6	1	Cout	CAP., X5R, 47uF, 6.3V, 20% 1812	TDK, C4532X5R0J476M
7	1	Cpl	CAP., X7R, 2200pF, 50V, 20% 0402	AVX, 04025C222MAT
8	0	D1 (OPT.)	DIODE, MBR0520	
9	8	E1-E7	TURRET,	MILL-MAX2501-2
10	2	JP1,JP2	JUMPER, 0.079, 3 PIN	COMM CON2802S-03G1
11	1	JP3	JUMPER, DOUBLE ROW 0.079X4	COMM CON2202S-08G1
12	3	JP1,JP2,JP3	SHUNT,	COMM CON. CCIJ2MM-138G
13	1	L1	INDUCTOR,4.7uH, D63LCB	TOKO, A921CY-4R7M
14	1	Rc	RES.,CHIP, 150K, 1/16W, 5% 0402	AAC, CR05-154JM
15	1	Rfb1	RES.,CHIP, 887K, 1/16W, 1% 0402	AAC, CR05-8873FM
16	1	Rfb2	RES.,CHIP, 698K, 1/16W, 1% 0402	AAC, CR05-6983FM
17	1	Rfb3	RES.,CHIP, 412K, 1/16W, 1% 0402	AAC, CR05-4123FM
18	1	Rfb4	RES.,CHIP, 280K, 1/16W, 1% 0402	AAC, CR05-2803FM
19	0	Rfb5 (optional)	RES.,CHIP, 0402	
20	1	Rin	RES.,CHIP, 10, 1/16W, 1% 0402	AAC, CR05-10R0FM
21	1	Rpg	RES.,CHIP, 100K, 1/16W, 5% 0402	AAC, CR05-104JM
22	1	Rpl	RES.,CHIP, 10K, 1/16W, 5% 0402	AAC, CR05-103JM
23	1	Rss	RES.,CHIP, 1M, 1/16W, 5% 0402	AAC, CR05-105JM
24	1	U1	I.C., LTC1879EGN, SSOP-16GN	LINEAR, LTC1879EGN
25	1		PRINTED CIRCUIT BOARD	DEMO BOARD DC432A

Mouser Electronics

Authorized Distributor

Click to View Pricing, Inventory, Delivery & Lifecycle Information:

[Analog Devices Inc.:](#)

[DC432B](#) [DC432A](#)