

**MATERIALS & FINISHES**

BODY: BRASS  
PLATED: SEE TABLE

CONTACT: BERYLLIUM COPPER  
PLATED: GOLD

INSULATOR: TEFLON

KAPTON: POLYIMIDE FILM  
(ON -1355 ONLY)

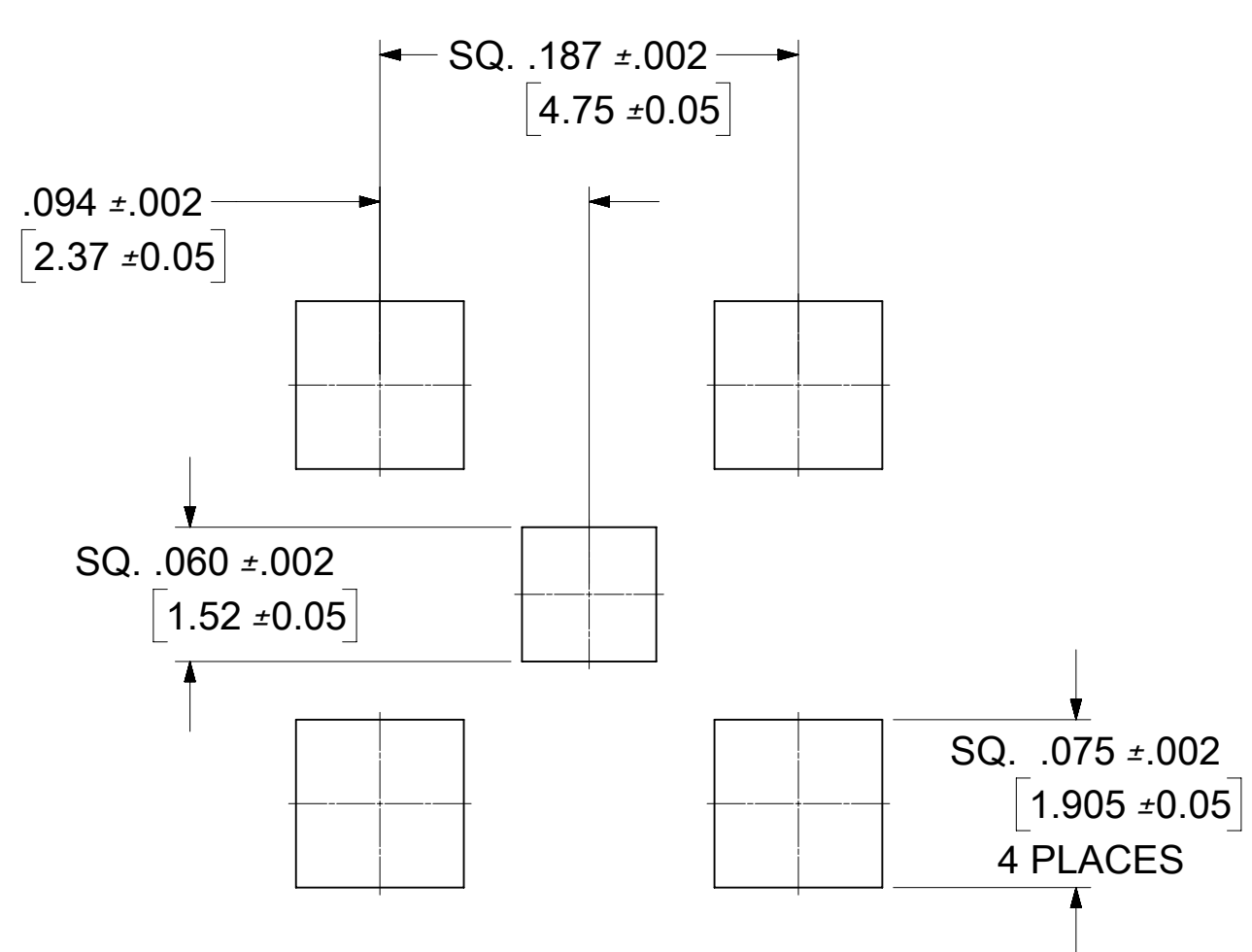
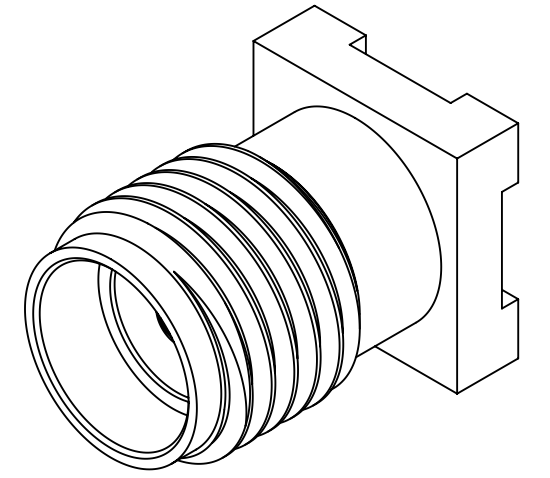

RECOMMENDED PCB LAYOUT

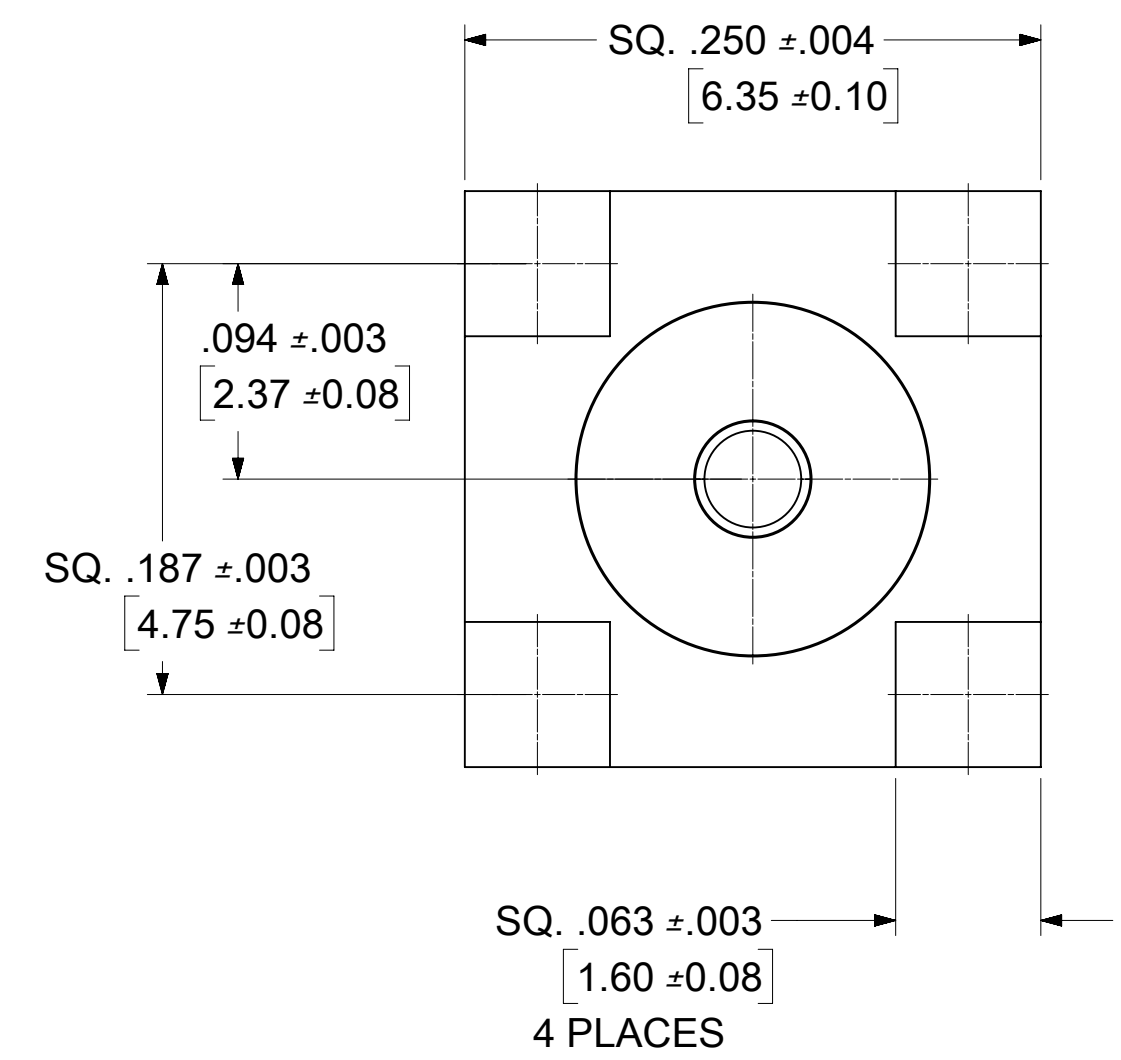
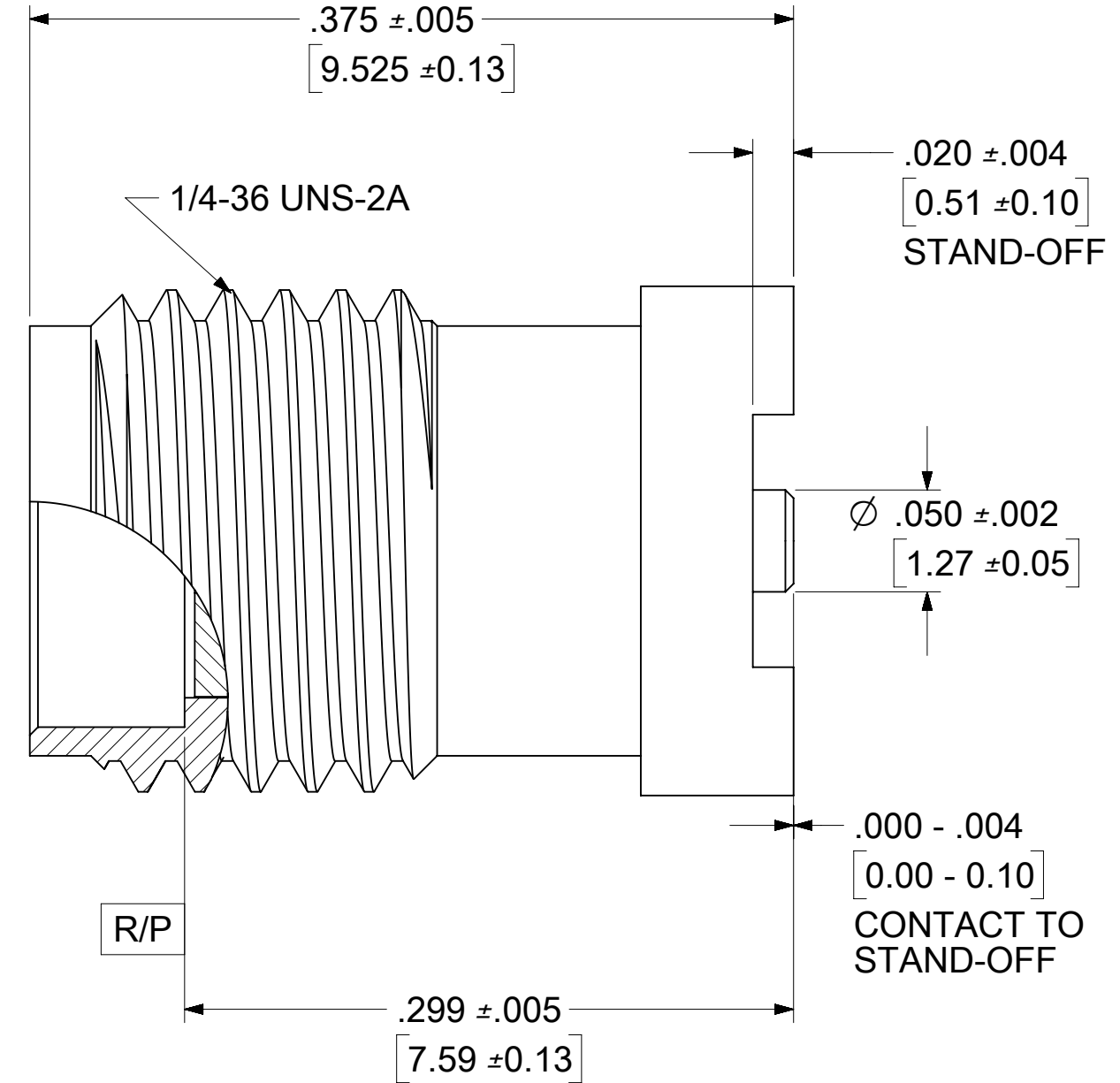

73251-1356	BODY/CONTACT GOLD (5μ" MIN.)	TAPE & REEL (400 PCS / REEL)
73251-1355	SAME AS 73251-1350	TAPE & REEL WITH KAPTON (400 PCS / REEL)
73251-1354	SAME AS 73251-1353	TAPE & REEL (400 PCS / REEL)
73251-1353	BODY NICKEL(100μ" MIN.)/ CONTACT GOLD (10μ" MIN.)	TRAY PACK (80 PCS / TRAY)
73251-1352	SAME AS 73251-1350	ONE PIECE 73251-1350 PER BAG
73251-1351	SAME AS 73251-1350	TAPE & REEL (400 PCS / REEL)
73251-1350	BODY/CONTACT GOLD (10μ" MIN.)	TRAY PACK (80 PCS / TRAY)
PART NO.	PLATING	PACKAGING DESCRIPTION

PS-89675-3460	ELEC/MECH PERFORMANCE
MIL-STD-348A, FIG. 310.2	INTERFACE
SPECIFICATION	DESCRIPTION

C3	2019/08/22	ADD -1351 & 1353 PKG PER EWR13301-A
C2	2018/12/27	ADD PACKAGING TOL. PER EWR12756-A
REV.	DATE	DESCRIPTION

THIS DRAWING CONTAINS INFORMATION THAT IS PROPRIETARY TO MOLEX ELECTRONIC TECHNOLOGIES, LLC AND SHOULD NOT BE USED WITHOUT WRITTEN PERMISSION											
SYMBOLS		DIMENSION UNITS		SCALE		CURRENT REV DESC:					
▽ = 0	▽ = 0	▽ = 0	▽ = 0	▽ = 0	▽ = 0	▽ = 0	▽ = 0	▽ = 0	▽ = 0	▽ = 0	▽ = 0
HYBRID		NTS		GENERAL TOLERANCES (UNLESS SPECIFIED)		ANGULAR TOL ± 2.0°		EC NO: 622824		DRWN: CWEI02	
4 PLACES ±		3 PLACES ±		2 PLACES ±		1 PLACE ±		0 PLACES ±		DRAFT WHERE APPLICABLE MUST REMAIN WITHIN DIMENSIONS	
THIRD ANGLE PROJECTION		DRAWING		SERIES		MATERIAL NUMBER		CUSTOMER		SHEET NUMBER	
C-SIZE		73251		SEE TABLE		GENERAL MARKET		1 OF 4		1	

**molex**

SMA, JACK  
VERTICAL PCB SMT SMA-J/PCB, EWR-2107

PRODUCT CUSTOMER DRAWING

DOCUMENT NUMBER	DOC TYPE	DOC PART	REVISION
SD-73251-135	PSD	001	C3

NOTE:  
TAPE AND REEL PACKAGING (SHEET 2 & 3) FOR  
73251-1351, 73251-1354, 73251-1355 AND 73251-1356.

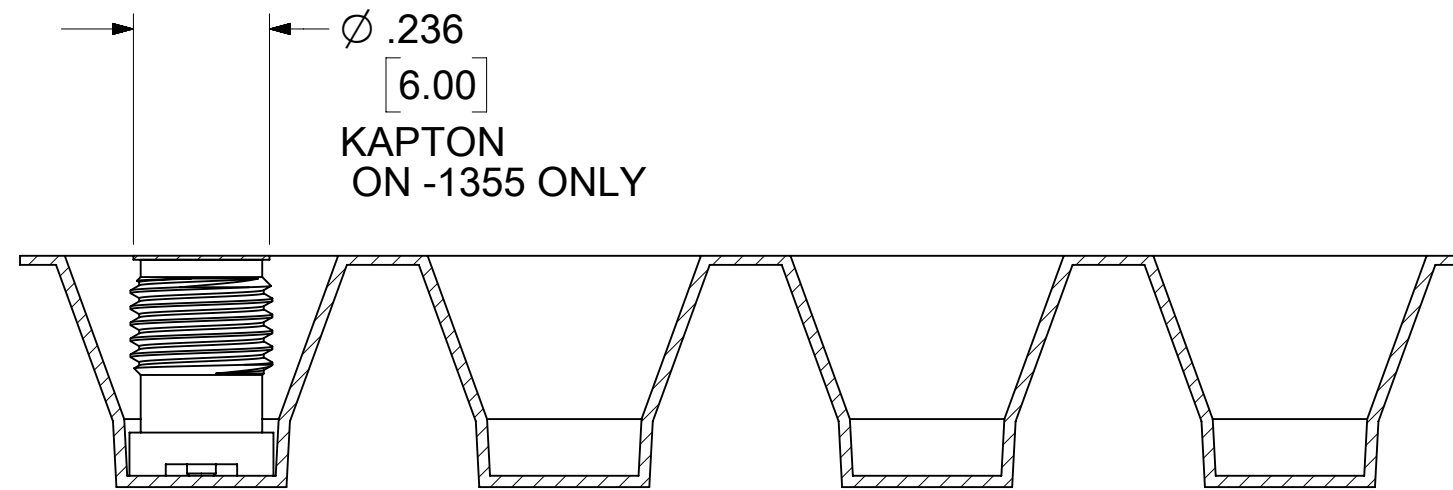
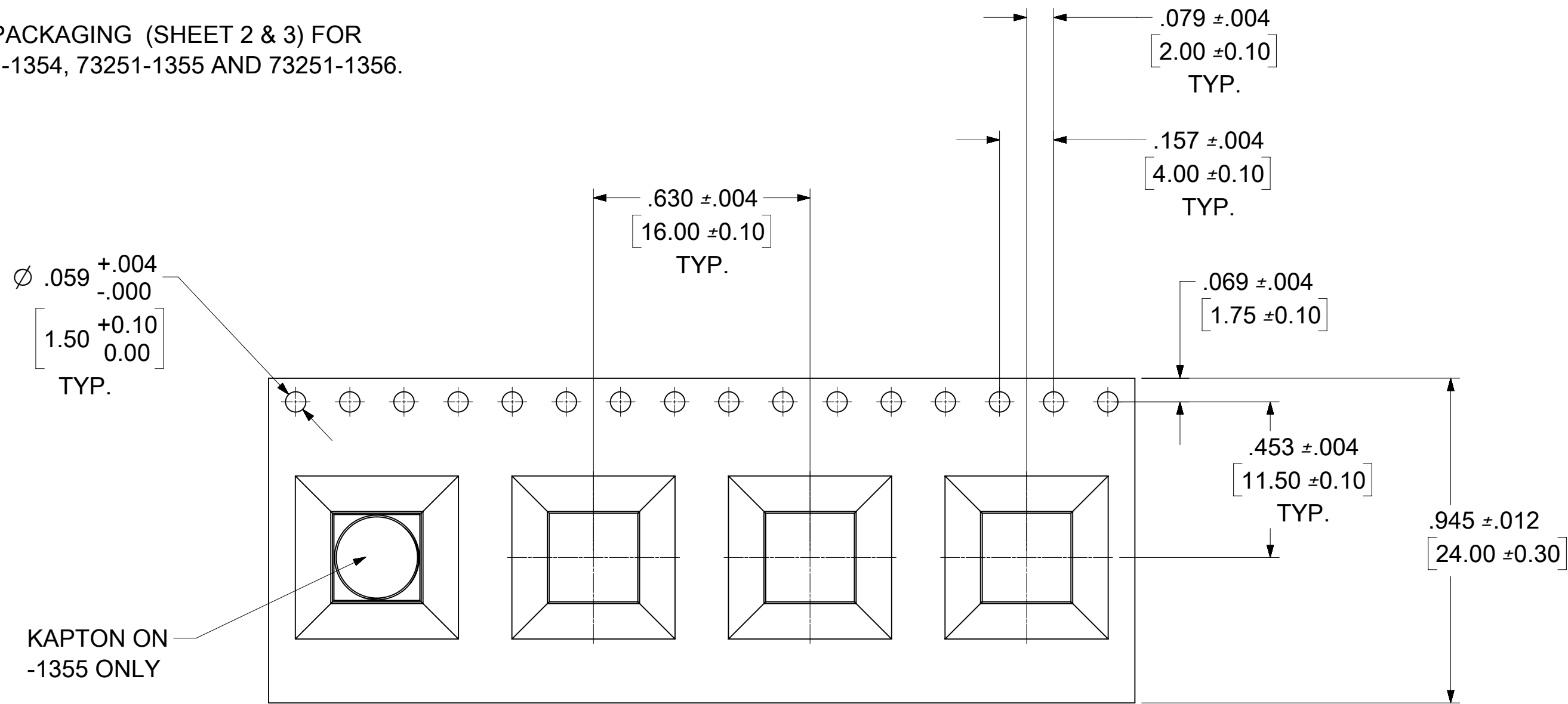

SYMBOLS		THIS DRAWING CONTAINS INFORMATION THAT IS PROPRIETARY TO MOLEX ELECTRONIC TECHNOLOGIES, LLC AND SHOULD NOT BE USED WITHOUT WRITTEN PERMISSION	
DIMENSION UNITS	SCALE	CURRENT REV DESC:	
$\nabla = 0$	HYBRID	EC NO: 622824	2019/08/22
$\nabla = 0$	NTS	DRWN: CWEI02	2019/08/23
$\nabla = 0$	GENERAL TOLERANCES (UNLESS SPECIFIED)	CHK'D: YCHENG	2019/08/23
$\nabla = 0$	ANGULAR TOL $\pm 2.0^\circ$	APPR: YCHENG	2019/08/23
$\nabla = 0$	4 PLACES $\pm$	INITIAL REVISION:	
$\nabla = 0$	3 PLACES $\pm$	DRWN: SSS	2000/05/16
$\nabla = 0$	2 PLACES $\pm$	APPR: GMH	2000/05/16
$\nabla = 0$	1 PLACE $\pm$	THIRD ANGLE PROJECTION	
$\nabla = 0$	0 PLACES $\pm$	DRAWING SERIES	
$\nabla = 0$	DRAFT WHERE APPLICABLE MUST REMAIN WITHIN DIMENSIONS	C-SIZE	73251

  

DOCUMENT NUMBER		SD-73251-135		DOC TYPE	DOC PART	REVISION
		PSD	001	C3		
MATERIAL NUMBER		CUSTOMER		SHEET NUMBER		
SEE TABLE		GENERAL MARKET		2 OF 4		

**molex**

SMA, JACK  
VERTICAL PCB SMT SMA-J/PCB, EWR-2107

PRODUCT CUSTOMER DRAWING

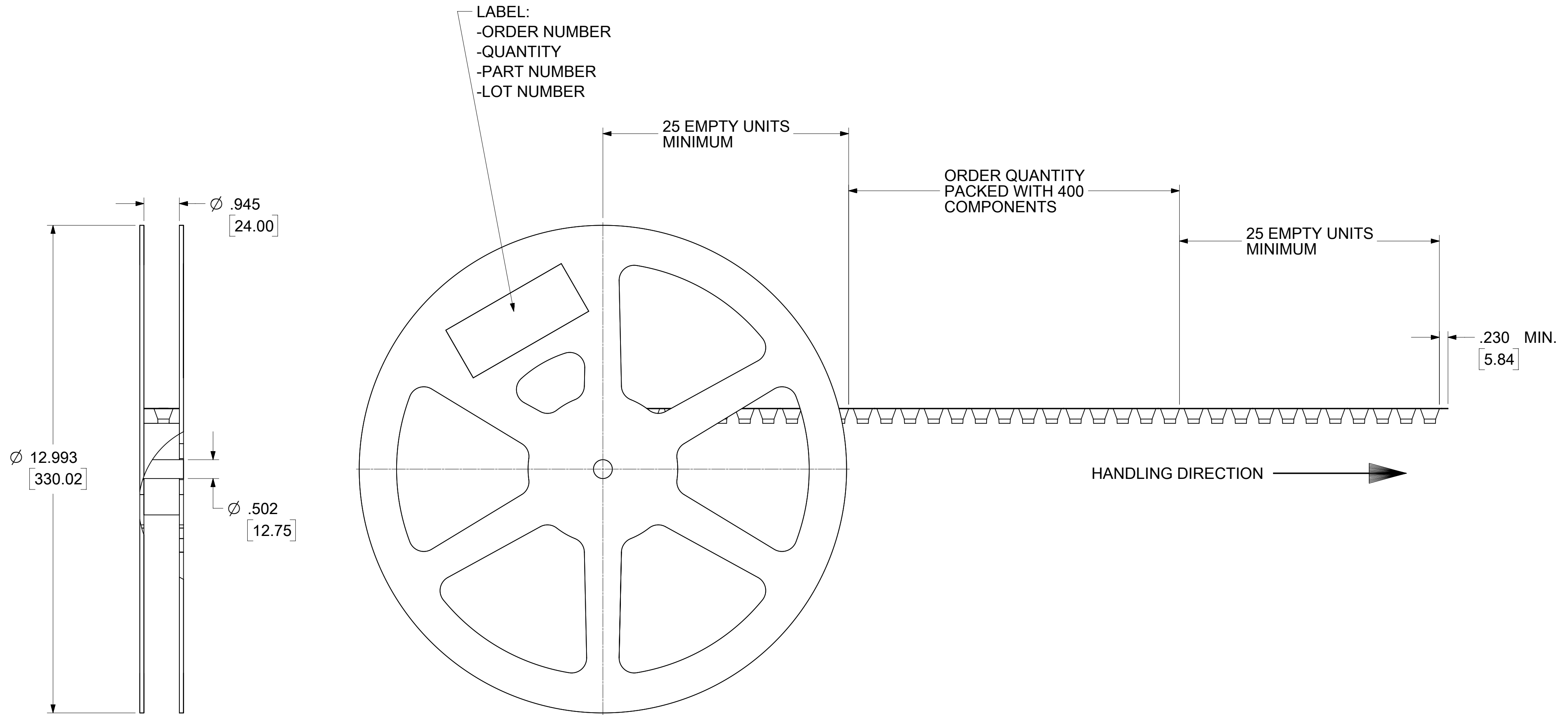

<b>SYMBOLS</b> ▽ = 0 ▽ = 0 ▽ = 0 ▽ = 0 ▽ = 0 ▽ = 0 ▽ = 0 ▽ = 0 ▽ = 0 ▽ = 0	THIS DRAWING CONTAINS INFORMATION THAT IS PROPRIETARY TO MOLEX ELECTRONIC TECHNOLOGIES, LLC AND SHOULD NOT BE USED WITHOUT WRITTEN PERMISSION					
	DIMENSION UNITS	SCALE	CURRENT REV DESC:			
	HYBRID	NTS				
	GENERAL TOLERANCES (UNLESS SPECIFIED)					
	ANGULAR TOL	± 2.0°	EC NO: 622824			
	4 PLACES	±	DRWN: CWEI02 2019/08/23			
	3 PLACES	±	CHK'D: YCHENG 2019/08/23			
	2 PLACES	±	APPR: YCHENG 2019/08/23			
	1 PLACE	±	INITIAL REVISION:			
	0 PLACES	±	DRWN: SSS 2000/05/16			
DRAFT WHERE APPLICABLE MUST REMAIN WITHIN DIMENSIONS						
THIRD ANGLE PROJECTION	DRAWING	SERIES	DOCUMENT NUMBER	DOC TYPE	DOC PART	REVISION
	C-SIZE	73251	SD-73251-135	PSD	001	C3
MATERIAL NUMBER		CUSTOMER	SHEET NUMBER			
SEE TABLE		GENERAL MARKET	3 OF 4			

DOCUMENT STATUS	P1	RELEASE DATE	2019/08/23 02:10:14
-----------------	----	--------------	---------------------

NOTE:  
TRAY PACKAGING FOR 73251-1350 AND 73251-1353

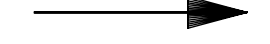
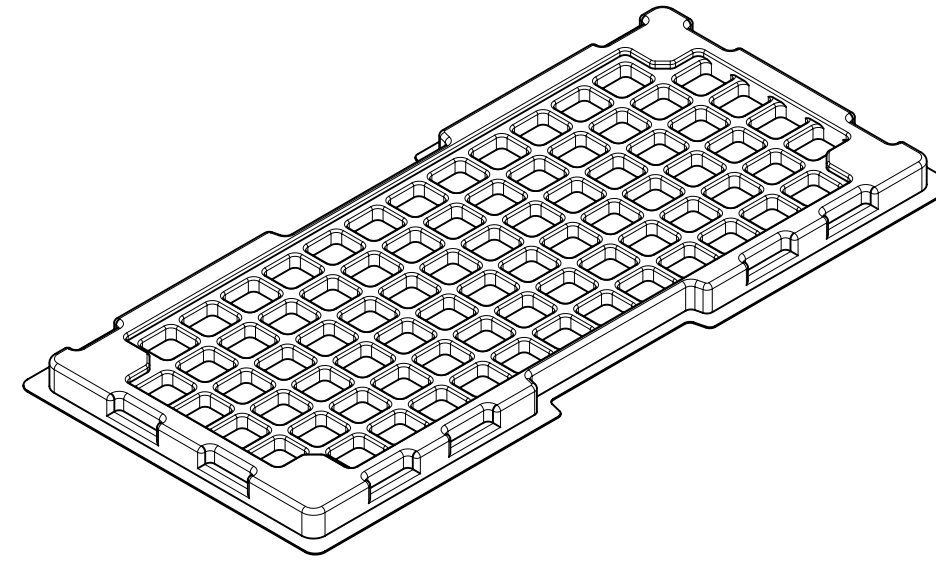
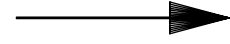
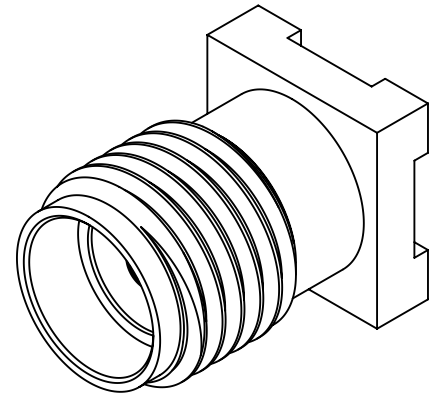

80 SETS PER TRAY  
P/N: 89707-0190

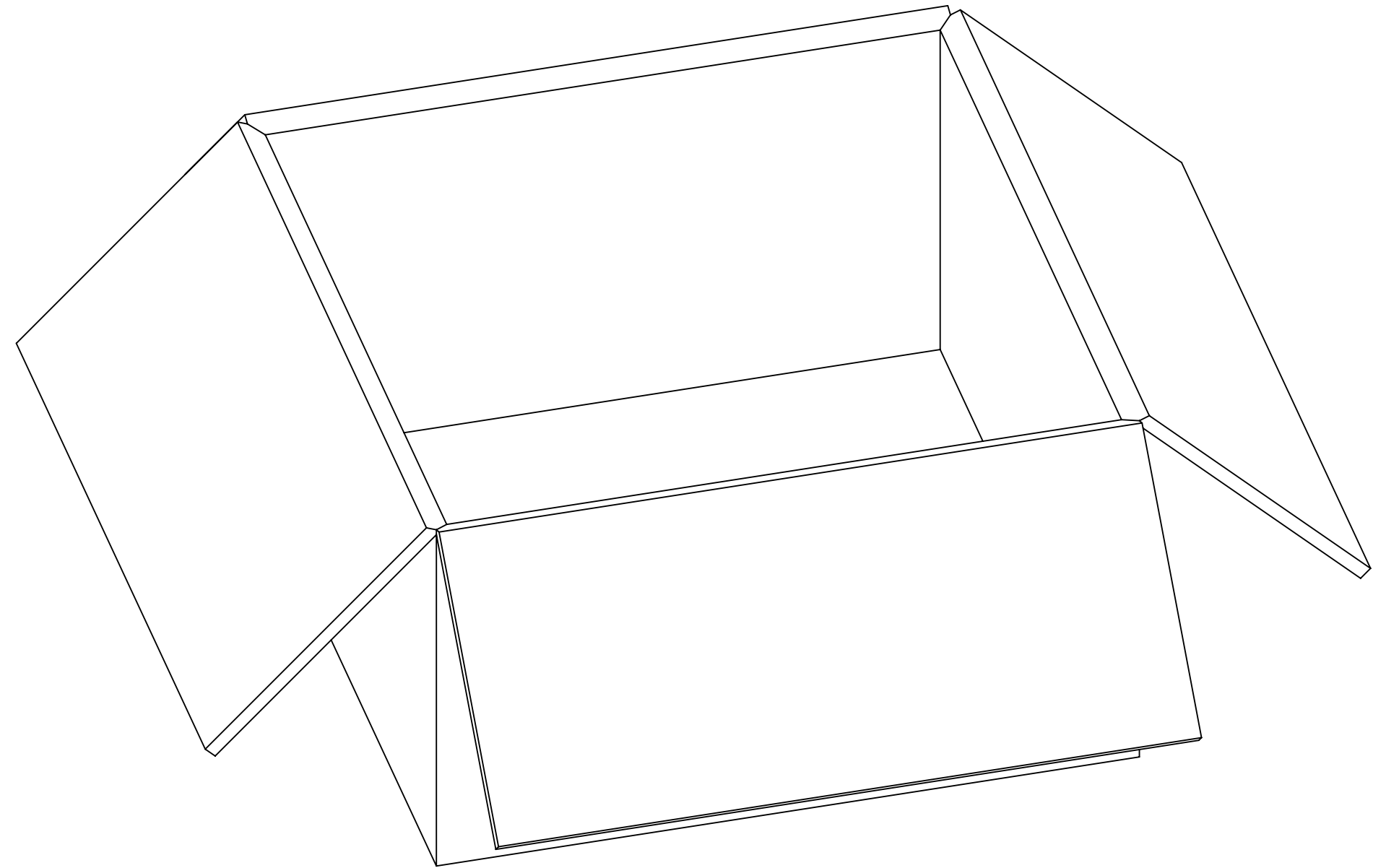
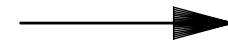
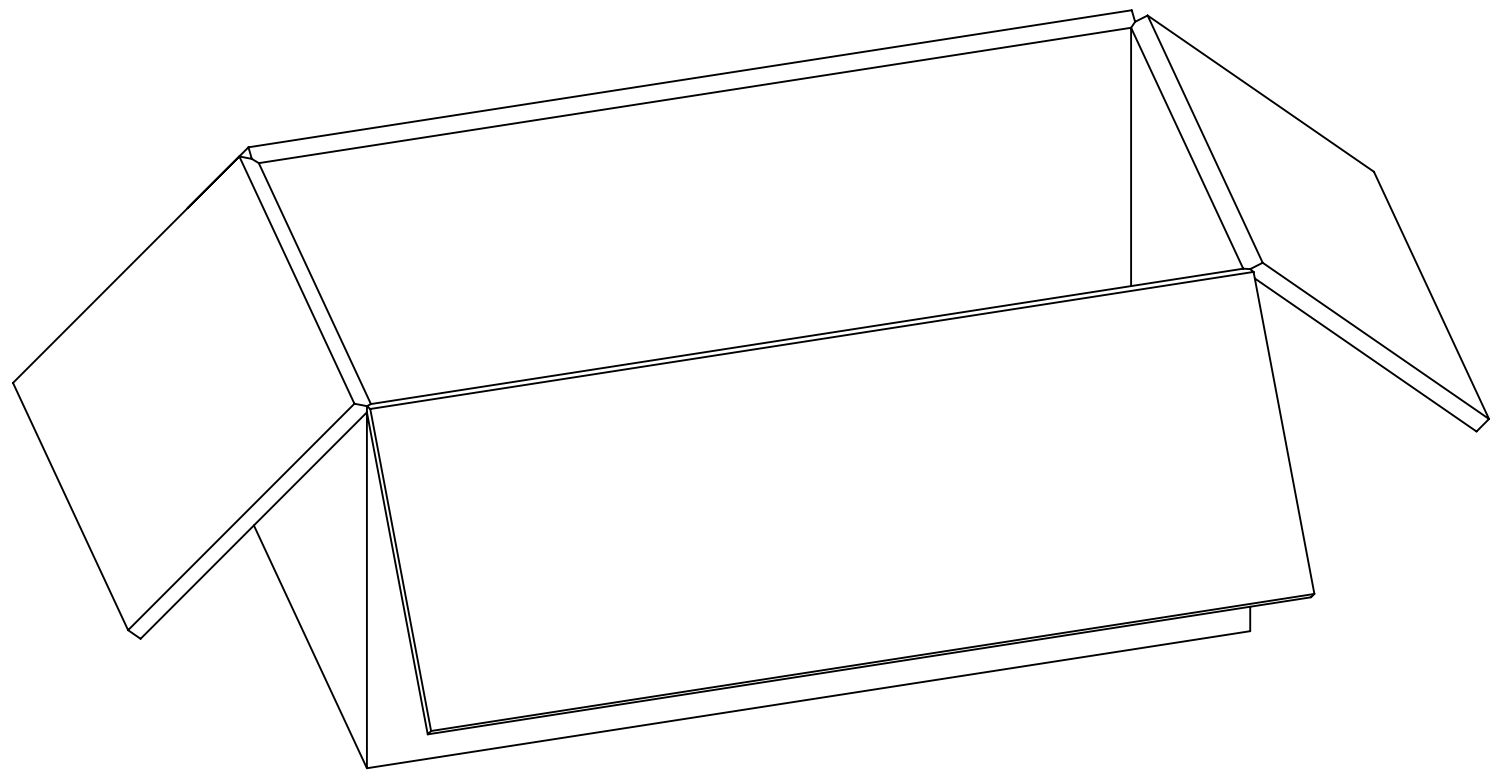

1600 SETS PER INNER  
CARTON BOX  
P/N: 96707-0001

3200 SETS PER OUTER  
CARTON BOX  
P/N: 96708-0005

<b>SYMBOLS</b> = 0 = 0 = 0 = 0 = 0 = 0 = 0 = 0 = 0	THIS DRAWING CONTAINS INFORMATION THAT IS PROPRIETARY TO MOLEX ELECTRONIC TECHNOLOGIES, LLC AND SHOULD NOT BE USED WITHOUT WRITTEN PERMISSION																				
	DIMENSION UNITS		SCALE		CURRENT REV DESC:																
	HYBRID		NTS																		
	GENERAL TOLERANCES (UNLESS SPECIFIED)										EC NO: 622824										
	ANGULAR TOL ± 2.0°										DRWN: CWEI02		2019/08/22		SMA, JACK VERTICAL PCB SMT SMA-J/PCB, EWR-2107						
	4 PLACES ±				CHK'D: YCHENG		2019/08/23		PRODUCT CUSTOMER DRAWING												
	3 PLACES ±				APPR: YCHENG		2019/08/23														
	2 PLACES ±				INITIAL REVISION:						DOCUMENT NUMBER		DOC TYPE		DOC PART		REVISION				
	1 PLACE ±				DRWN: RFC_PLMIMP		2017/12/12		SD-73251-135				PSD		001		C3				
	0 PLACES ±				APPR: JWIENER		2005/07/25		MATERIAL NUMBER		CUSTOMER		SHEET NUMBER								
DRAFT WHERE APPLICABLE MUST REMAIN WITHIN DIMENSIONS										THIRD ANGLE PROJECTION		DRAWING		SERIES		SEE TABLE		GENERAL MARKET		4 OF 4	
												C-SIZE		73251							

DOCUMENT STATUS	P1	RELEASE DATE	2019/08/23	02:10:14
-----------------	----	--------------	------------	----------