

THIS DRAWING IS UNPUBLISHED. RELEASED FOR PUBLICATION  
 © COPYRIGHT BY TYCO ELECTRONICS CORPORATION. ALL RIGHTS RESERVED.

LOC	DIST	REVISIONS			
P	LTR	DESCRIPTION	DATE	DWN	APVD
-	-	A	REV PER ECO 10-023341	11-16-10	CT KH

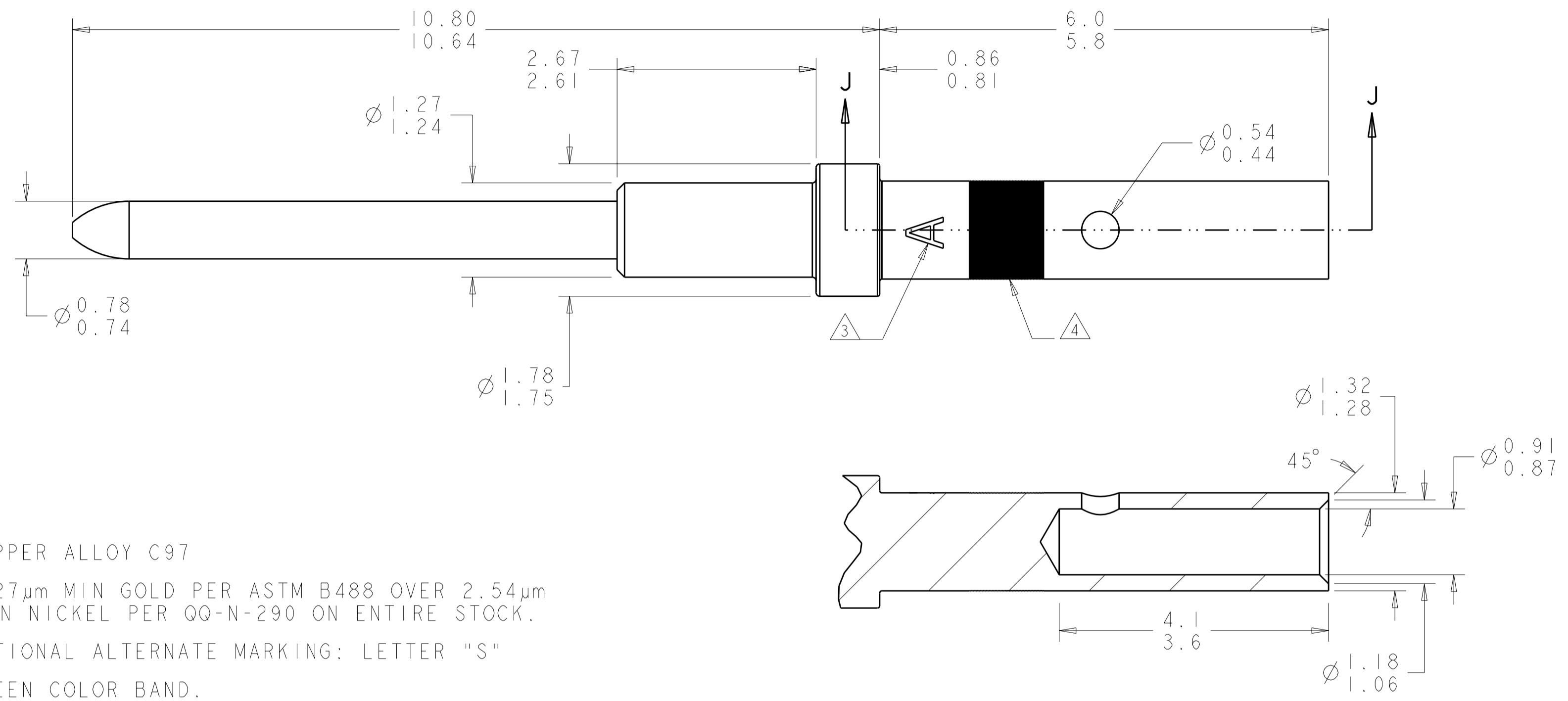

- ① COPPER ALLOY C97
- ② 1.27µm MIN GOLD PER ASTM B488 OVER 2.54µm MIN NICKEL PER QQ-N-290 ON ENTIRE STOCK.
- ③ OPTIONAL ALTERNATE MARKING: LETTER "S"
- ④ GREEN COLOR BAND.
- 5. APPLICABLE WIRE SIZE: 22-24-26 AWG  
 WIRE INSULATION DIAMETER: 1.4 MAX  
 INSULATION STRIP LENGTH: 3.08-3.58
- 6. APPLICATION TOOLING:  
 CRIMPING TOOL: TYCO PART NUMBER 601966-1 (M22520/2-01)  
 POSITIONER: TYCO PART NUMBER 601966-8 (M22520/2-23)  
 SELECTOR POSITION: AWG 22: 4  
                                   AWG 24: 3  
                                   AWG 26: 3  
 CONTACT INSERTION/EXTRCTION TOOL: 91066-1 (M81969/1-01)
- 7. THIS PRODUCT IS SOLD BY TYCO ELECTRONICS UNDER A LICENSE FROM RADIALL SA.

SECTION J-J

1738007-1  
 PART NUMBER

THIS DRAWING IS A CONTROLLED DOCUMENT FOR TYCO ELECTRONICS CORPORATION. IT IS SUBJECT TO CHANGE AND THE CONTROLLING ENGINEERING ORGANIZATION SHOULD BE CONTACTED FOR THE LATEST REVISION.		DWN BH	12AUG2004	Tyco Electronics Harrisburg, PA 17105-3608	
DIMENSIONS: mm		CHK JPM	12AUG2004		
TOLERANCES UNLESS OTHERWISE SPECIFIED: 0 PLC ± 1 PLC ± 2 PLC ± 3 PLC ± 4 PLC ± ANGLES ±30' FINISH		APVD JPM	12AUG2004	NAME PIN CONTACT, SIZE 22, GPR	
MATERIAL		PRODUCT SPEC	-	SIZE	A2
①		APPLICATION SPEC	-	CAGE CODE	00779
②		WEIGHT	-	DRAWING NO	1738007
CUSTOMER DRAWING		SCALE: 20:1		SHEET	1 OF 1
				REV	A

# Mouser Electronics

Authorized Distributor

Click to View Pricing, Inventory, Delivery & Lifecycle Information:

[TE Connectivity:](#)

[1738007-1](#)