

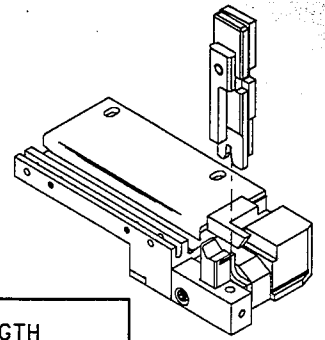

APPLICATION TOOLING TERMINATOR DIE SPECIFICATION SHEET



TERMINAL SPECIFICATION

TERMINAL SERIES	WIRE SIZE		INSULATION DIAMETER		STRIP LENGTH	
	AWG		ENGLISH	(METRIC)	ENGLISH	(METRIC)
- VER.	MIN	MAX				
43375-0001	18	14	.093 - .140	(2.36 - 3.56)	.156 - .218	(3.96 - 5.54)
			-	(-)	-	(-)
			-	(-)	-	(-)
			-	(-)	-	(-)
			-	(-)	-	(-)
			-	(-)	-	(-)
			-	(-)	-	(-)

TOOLING INFORMATION

ITEM	ORDER NO.	SIZE	ENG. NO.	DESCRIPTION	REQ'D
4	634430002	B	634430002	FRONT CUT-OFF PLUNGER	1
6	634442513	B	634442513	CONDUCTOR PUNCH	1
7	634452562	B	634452562	CONDUCTOR ANVIL	1
8	634463937	B	634463937	INSULATION PUNCH	1
9	634453947	B	634453947	INSULATION ANVIL	1
***	6384050-70		6384050-70	TOOL KIT (ALL THE ABOVE ITEMS)	1

CRIMP SPECIFICATION

WIRE AWG	CRIMP HEIGHT		CRIMP WIDTH (REF.)		PULL FORCE MINIMUM	
	ENGLISH	(METRIC)	ENGLISH	(METRIC)	LBS.	(N)
14	.065 - .069	(1.65 - 1.75)	.098	(2.50)	60	(266)
16	.058 - .062	(1.47 - 1.57)	.098	(2.50)	30	(133)
18	.053 - .056	(1.35 - 1.43)	.098	(2.50)	20	(88.9)
	-	(-)		()		()
	-	(-)		()		()

NOTES:

1. WE RECOMMEND AN EXTRA SET OF PERISHABLE TOOLING BE MAINTAINED IN YOUR FACTORY.
2. VERIFY TOOLING ALIGNMENT BY MANUALLY CYCLING THE PRESS AND DIE BEFORE CRIMPING UNDERPOWER. CHECK THAT ALL SCREWS ARE TIGHT.
3. SLUGS, TERMINALS, DIRT AND OIL SHOULD BE KEPT CLEAR OF WORK AREA.
4. CRIMP HEIGHT MAY VARY DEPENDING ON STYLE AND WIRE TYPE.
5. TO PREVENT INJURY - NEVER OPERATE THIS TOOL WITHOUT THE GUARDING SUPPLIED WITH THE PRESS IN PLACE.

CRIMP

DD-MMM-YY
HH:MM

WORK AREA

REV. BDL OF MATERIALS

PERMFCN 04C9160A

09-13-97 KDP

REVISIONS

MFG. SH. REV. C

LTR.

DIMENSIONS SHOWN (METRIC) INCH

UNLESS OTHERWISE SPECIFIED TOLERANCES: ANGULAR ± 1/2°

	INCH	METRIC
3 PLACE	± ---	---
2 PLACE	± ---	± ---
1 PLACE	---	± ---

DRAFT WHERE APPLICABLE MUST REMAIN WITHIN DIMENSIONS

DRWG. BY: SMT CHK'D. BY: VS

APP'D. BY: SCALE: / : /

▽ = ▼ =

REVISIONS

TITLE

TERMINATOR DIE ASSEMBLY

MOLEX INCORPORATED SHEET NO. DATE

LISLE, ILL. 60532 U.S.A. 1 of 4 03/03/95

PART NO. DRWG. NO.

6384050-00 6384050-00

FILE NAME THIS DRAWING CONTAINS INFORMATION THAT IS PROPRIETARY TO MOLEX INC. AND SHOULD NOT BE USED WITHOUT WRITTEN PERMISSION. DIV. SIZE

6384050 580 AT A



APPLICATION TOOLING TERMINATOR DIE SPECIFICATION SHEET

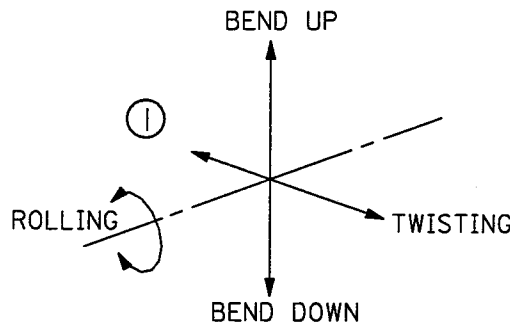
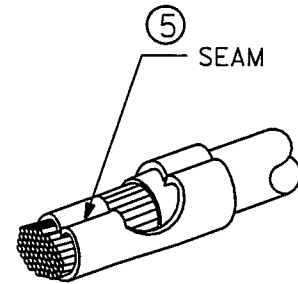
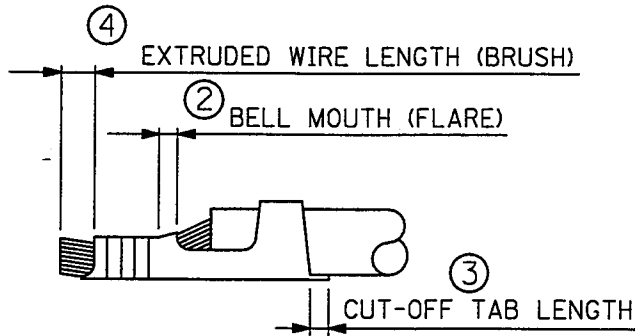
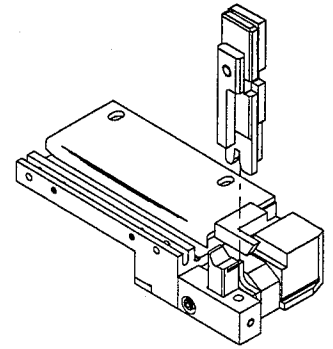

CRIMP SPECIFICATION

NO. OF FIG.	ITEM	REQUIREMENT
1	BEND UP	5° MAX
	BEND DOWN	2° MAX
	TWISTING	5° MAX
	ROLLING	5° MAX
2	BELL MOUTH (FLARE)	0.2 - 0.5mm
3	CUT-OFF TAB LENGTH	0.2mm MAX
4	EXTRUDED WIRE LENGTH (BRUSH)	0.0 - 0.5 mm
5	SEAM	SEAM SHALL NOT BE OPENED AND NO WIRE ALLOWED OUT OF THE CRIMPING AREA.

CRIMP

DD-MMM-YY
 HH:MM
 REV. BRN. OF MATERIALS
 PENN. ECN 09/16/04
 09-15387 KDP
 REV. 08/04
 WORK IN PROGRESS
 MFG. SH. C LTR.

DIMENSIONS SHOWN (METRIC) INCH

UNLESS OTHERWISE SPECIFIED TOLERANCES: ANGULAR ± 1/2°

	INCH	METRIC
3 PLACE	± ---	---
2 PLACE	± ---	± ---
1 PLACE	---	± ---

DRAFT WHERE APPLICABLE MUST REMAIN WITHIN DIMENSIONS

DRWG. BY SMT CHK'D. BY VS

APP'D. BY SCALE / : /

▽ = ▼ = REVISE ONLY ON CAD SYSTEM

TITLE: TERMINATOR DIE ASSEMBLY

MOLEX INCORPORATED SHEET NO. 2 of 4 DATE 03/03/95
 LISLE, ILL. 60532 U.S.A.

PART NO. 6384050-00 DRWG. NO. 6384050-00

FILE NAME 6384050 S81 THIS DRAWING CONTAINS INFORMATION THAT IS PROPRIETARY TO MOLEX INC. AND SHOULD NOT BE USED WITHOUT WRITTEN PERMISSION. DIV. AT SIZE A



APPLICATION TOOLING TERMINATOR DIE SPECIFICATION SHEET

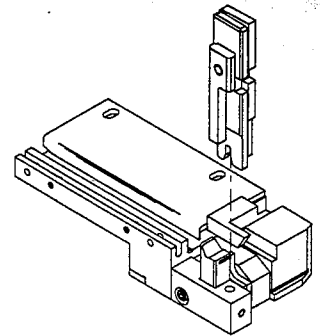

TOOLING INFORMATION

ITEM	ORDER NO.	SIZE	ENG. NO.	DESCRIPTION	REQ'D
4	634430002	B	634430002	FRONT CUT-OFF PLUNGER	1
6	634442513	B	634442513	CONDUCTOR PUNCH	1
7	634452562	B	634452562	CONDUCTOR ANVIL	1
8	634463937	B	634463937	INSULATION PUNCH	1
9	634453947	B	634453947	INSULATION ANVIL	1
***	6384050-70		6384050-70	TOOL KIT (ALL THE ABOVE ITEMS)	1

TERMINATOR ASSEMBLY - PARTS LIST

ITEM	ORDER NO.	SIZE	ENG. NO.	DESCRIPTION	REQ'D
5	634430012	B	634430012	CUT-OFF PLUNGER RETAINER	1
10	11-40-4039	B	8302-5	PLUNGER STRIKER	1
11	634430021	B	634430021	MOUNTING KEY	1
12	638405012	B	638405012	ANVIL MOUNT	1
13	11-40-4068	B	8302-102	DRAG FINGER (L.H.)	1
14	638405014	B	638405014	DRAG FINGER (R.H.)	1
15					
16					
17	638405017	B	638405017	COVER	1
18	11-24-1067	A	4996-4	CUT-OFF PLUNGER SPRING	1
19	638405019	B	638405019	WIRE STOP	1
20	638405020	C	638405020	TERMINAL TRACK	1
21					
22	11-40-4144	B	8302-110	TORSION SPRING, DRAG FINGER	2
23					
24	11-40-4069	B	8302-103	PIVOT PIN	2
25					
26					
27					
28					
29					

CRIMP

DD-MMM-YY
HH:MM

REV. BDL OF MATERIALS
PER ECN 01091804
09-15-87 KDP

WORK IN PROGRESS

REVISIONS

MFG. SH. REV. C

LTR.

DIMENSIONS SHOWN (METRIC) INCH

UNLESS OTHERWISE SPECIFIED
TOLERANCES: ANGULAR ± 1/2°

	INCH	METRIC
3 PLACE	± ---	---
2 PLACE	± ---	± ---
1 PLACE	---	± ---

DRAFT WHERE APPLICABLE MUST
REMAIN WITHIN DIMENSIONS

DRWG. BY SMT CHK'D. BY VS

APP'D. BY SCALE / : /

▽ = ▼ =

REVISE ONLY ON CAD SYSTEM

TITLE

TERMINATOR DIE ASSEMBLY

MOLEX INCORPORATED SHEET NO. DATE

LISLE, ILL. 60532 U.S.A. 3 of 4 03/03/95

PART NO. DRWG. NO.

6384050-00 6384050-00

FILE NAME THIS DRAWING CONTAINS INFORMATION THAT IS PROPRIETARY TO MOLEX INC. AND SHOULD NOT BE USED WITHOUT WRITTEN PERMISSION.

6384050 S82 DIV. SIZE

AT A

Mouser Electronics

Authorized Distributor

Click to View Pricing, Inventory, Delivery & Lifecycle Information:

Molex:

[63840-5070](#) [63840-5020](#)