

NHD-C12864A1Z-FSW-FBW-HTT

COG (Chip-On-Glass) Liquid Crystal Display Module

| | |
|---------|----------------------------------|
| NHD- | Newhaven Display |
| C12864- | 128 x 64 Pixels |
| A1Z- | Model |
| F- | Transflective |
| SW- | Side White LED Backlight |
| F- | FSTN (+) |
| B- | 6:00 Optimal View |
| W- | Wide Temp |
| HTT- | With 12V Heater (-40°C to +70°C) |
| | RoHS Compliant |

Newhaven Display International, Inc.

2661 Galvin Ct.

Elgin IL, 60124

Ph: 847-844-8795

Fax: 847-844-8796

www.newhavendisplay.com

nhtech@newhavendisplay.com

nhsales@newhavendisplay.com

Document Revision History

| Revision | Date | Description | Changed by |
|----------|------------|--|------------|
| 0 | 7/17/2008 | Initial Release | - |
| 1 | 9/28/2009 | User guide reformat | BE |
| 2 | 10/14/2009 | Updated Electrical Characteristic | MC |
| 3 | 11/20/2009 | Updated backlight supply current | MC |
| 4 | 10/26/2010 | Updated backlight current | BE |
| 5 | 10/27/2010 | Supply current updated | BE |
| 6 | 08/31/2015 | Electrical characteristics, Optical characteristics, Mechanical drawings updated | SB |
| 7 | 8/3/2016 | Updated Electrical Characteristics and Quality Info | TM |
| 8 | 9/23/16 | Updated Electrical Characteristics | TM |
| 9 | 3/30/17 | Updated Electrical Characteristics | TM |

Functions and Features

- 128 x 64 pixels
- Built-in ST7565P controller
- +3.3V power supply
- 1/65 duty cycle; 1/9 bias
- Built-in Heater
- RoHS Compliant

Mechanical Drawing

| Rev | Description | Date |
|-----|-------------|------|
| | | |

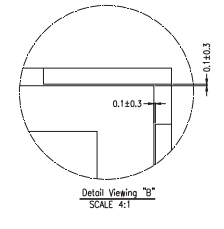
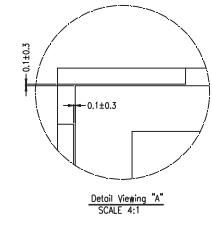
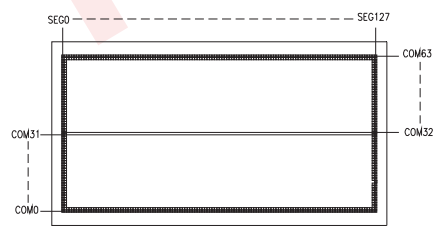
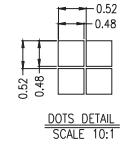
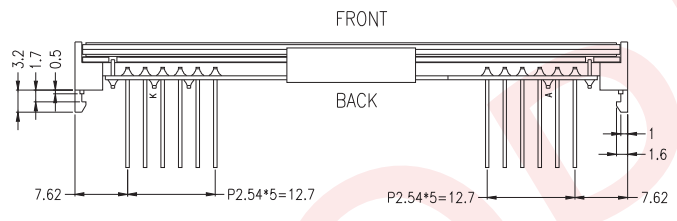
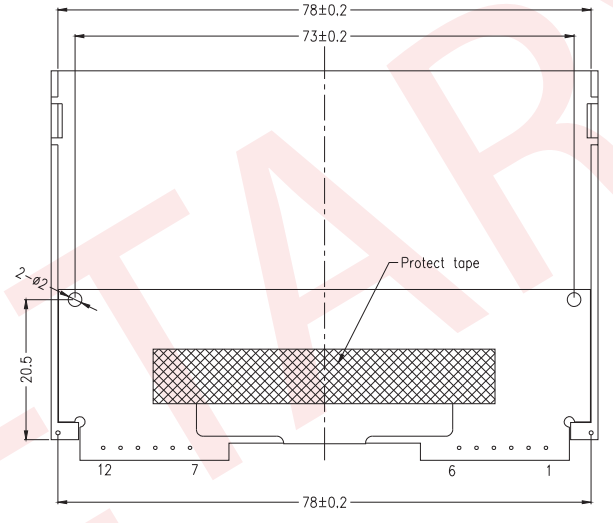
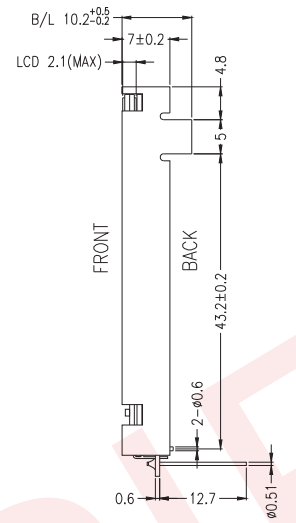
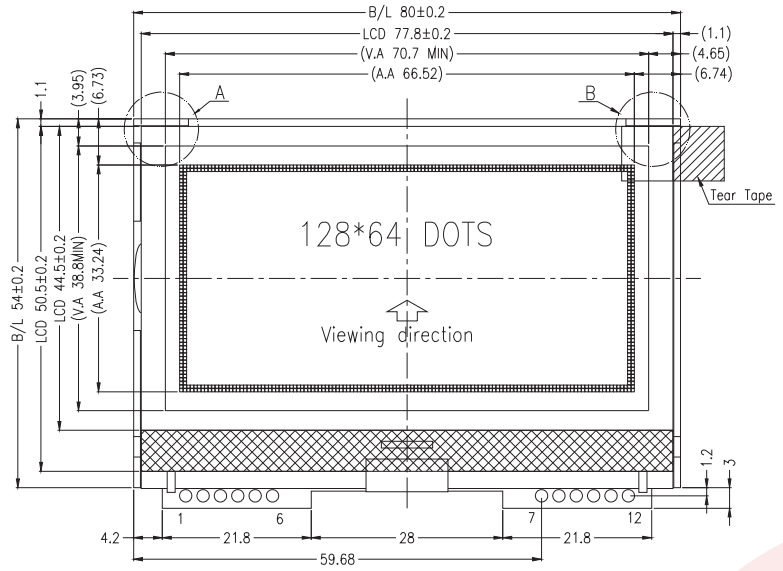

- Notes:**
- Driving: 1/65 duty, 1/9 bias
 - Voltage: 3.3V V_{DD}, 9V V_{LCD}
 - Display Type: FSTN Positive / Transflective
 - Optimal View: 6:00
 - Backlight: White Edge light LED
 - Driver IC: ST7565 2-Line SPI Interface
 - Built-in Heater & Temp Control

| Pin assignment | |
|----------------|--------|
| NO. | Symbol |
| 1 | SCL |
| 2 | SI |
| 3 | VDD |
| 4 | A0 |
| 5 | /RESET |
| 6 | /CS |
| 7 | VSS |
| 8 | H- |
| 9 | H+ |
| 10 | LED- |
| 11 | LED+ |
| 12 | NC |

| | | |
|-------------------|---|---|
| Unit mm |  | |
| Gen. Tol. ±0.3 | Date 3/30/17 | Part Number: NHD-C12864A1Z-FSW-FBW-HTT |

Pin Description and Wiring Diagram

| Pin No. | Symbol | External Connection | Function Description |
|---------|--------|---------------------|--|
| 1 | SCL | MPU | Serial Clock input |
| 2 | SI | MPU | Serial Data input |
| 3 | VDD | Power Supply | Supply Voltage for LCD and logic (+3.3V) |
| 4 | A0 | MPU | Register Select. 0: instruction; 1: data |
| 5 | /RESET | MPU | Operation Active LOW Reset signal |
| 6 | /CS | MPU | Active LOW Chip Select Signal |
| 7 | Vss | Power Supply | Ground |
| 8 | H- | Power Supply | Ground for Heater |
| 9 | H+ | Power Supply | Power for Heater (+12V) |
| 10 | LED- | Power Supply | Backlight Cathode (Ground) |
| 11 | LED+ | Power Supply | Backlight Anode (+3.3V) |
| 12 | NC | - | No Connect |

Recommended LCD connector: 2.54mm pitch thru-hole connection on PCB

Backlight connector: --- **Mates with:** ---

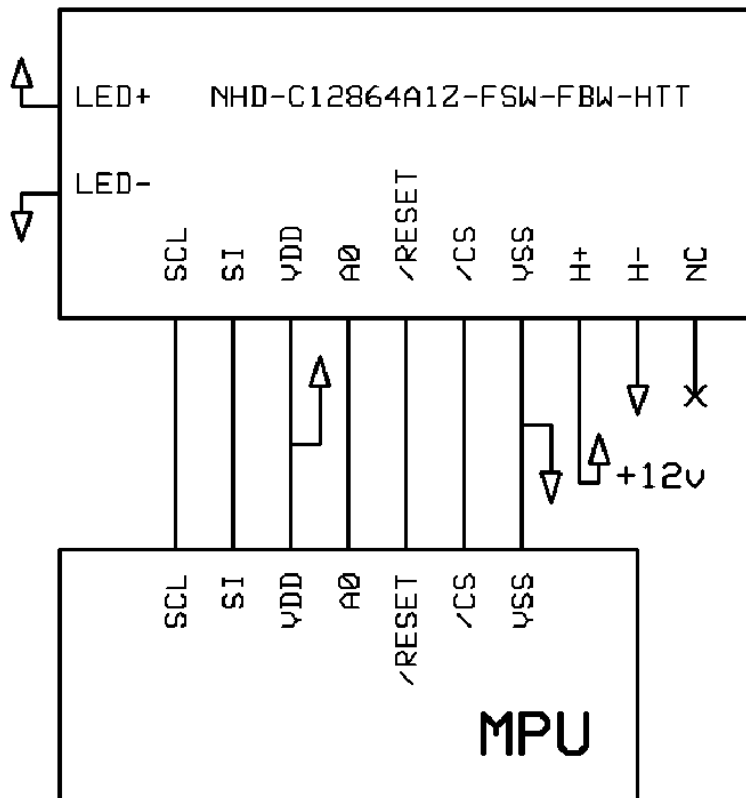

Electrical Characteristics

| Item | Symbol | Condition | Min. | Typ. | Max. | Unit |
|-----------------------------|-------------------|-------------------------|---------------------|------|---------------------|------|
| Operating Temperature Range | T _{OP} | V _H = 0V | -20 | - | +70 | °C |
| | | V _H = 12.0V | -40 | - | | |
| Storage Temperature Range | T _{ST} | - | --30 | - | +80 | °C |
| Supply Voltage | V _{DD} | - | 2.7 | 3.0 | 3.3 | V |
| Supply Current | I _{DD} | V _{DD} = 3.3V | 0.1 | 0.31 | 1.0 | mA |
| Supply for LCD (contrast) | V _{LCD} | T _{OP} = 25°C | 8.8 | 9.0 | 9.2 | V |
| "H" Level input | V _{IH} | - | 0.8*V _{DD} | - | V _{DD} | V |
| "L" Level input | V _{IL} | - | 0 | - | 0.2*V _{DD} | V |
| "H" Level output | V _{OH} | - | 0.8*V _{DD} | - | V _{DD} | V |
| "L" Level output | V _{OL} | - | V _{SS} | - | 0.2*V _{DD} | V |
| Backlight Supply Voltage | V _{LED} | - | - | 3.3 | - | V |
| Backlight Supply Current | I _{LED} | V _{LED} = 3.3V | 30 | 50 | 60 | mA |
| Heater panel resistance | R _{H+/-} | - | - | 20 | 25 | Ω |
| Heater Voltage Supply | V _H | - | - | 12V | - | V |
| Heater Current | I _H | V _H = 12.0V | 0.48 | 0.60 | 1 | A |

Optical Characteristics

| Item | Symbol | Condition | Min. | Typ. | Max. | Unit |
|------------------------|--------|----------------|------|------|------|------|
| Optimal Viewing Angles | Top | φY+ | - | 20 | - | ° |
| | Bottom | φY- | - | 40 | - | ° |
| | Left | θX- | - | 40 | - | ° |
| | Right | θX+ | - | 40 | - | ° |
| Contrast Ratio | CR | - | 2 | 4 | 10 | - |
| Response Time | Rise | T _R | 150 | 200 | 300 | ms |
| | Fall | T _F | 200 | 250 | 350 | ms |

Controller Information

Built-in ST7565P controller.

Please download specification at http://www.newhavendisplay.com/app_notes/ST7565.pdf

Timing Characteristics

The Serial Interface

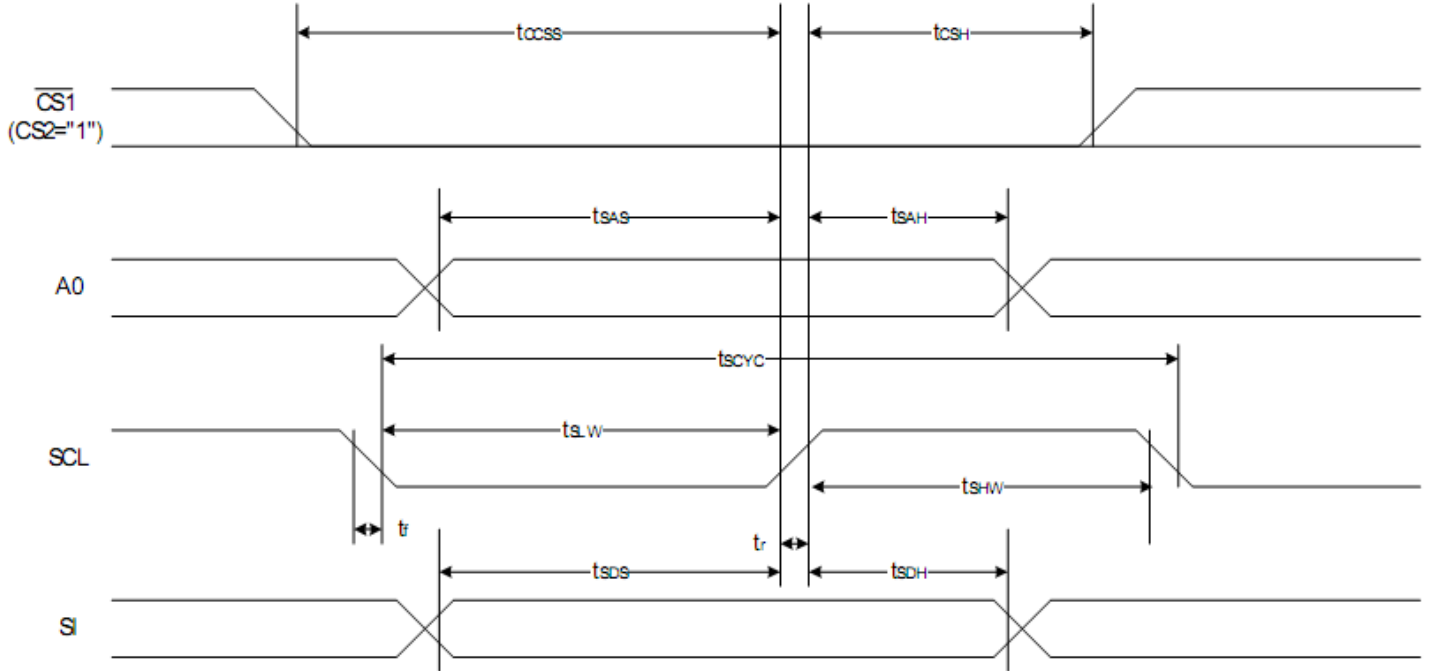

| Item | Signal | Symbol | Condition | Rating | | Units |
|---------------------|--------|------------|-----------|--------|------|-------|
| | | | | Min. | Max. | |
| Serial Clock Period | SCL | t_{SCYC} | | 400 | — | ns |
| SCL "H" pulse width | | t_{SHW} | | 120 | — | |
| SCL "L" pulse width | | t_{SLW} | | 120 | — | |
| Address setup time | A0 | t_{SAS} | | 50 | — | |
| Address hold time | | t_{SAH} | | 50 | — | |
| Data setup time | SI | t_{SDS} | | 50 | — | |
| Data hold time | | t_{SDH} | | 50 | — | |
| CS-SCL time | CS | t_{CSS} | | 50 | — | |
| CS-SCL time | | t_{CSH} | | 150 | — | |

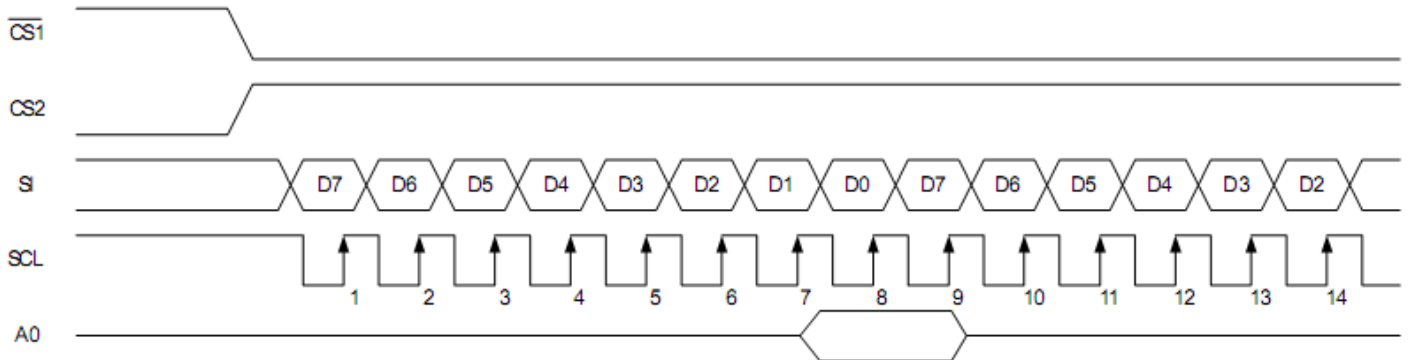

Table of Commands

| Command | Command Code | | | | | | | | Function | | | | |
|---|--------------|-----|-----|------------|----|-------------------------|----|----------------------------------|----------------|----|----|--|---|
| | A0 | /RD | /WR | D7 | D6 | D5 | D4 | D3 | | D2 | D1 | D0 | |
| (1) Display ON/OFF | 0 | 1 | 0 | 1 | 0 | 1 | 0 | 1 | 1 | 1 | 0 | 1 | LCD display ON/OFF 0: OFF, 1: ON |
| (2) Display start line set | 0 | 1 | 0 | 0 | 1 | Display start address | | | | | | Sets the display RAM display start line address | |
| (3) Page address set | 0 | 1 | 0 | 1 | 0 | 1 | 1 | Page address | | | | Sets the display RAM page address | |
| (4) Column address set upper bit | 0 | 1 | 0 | 0 | 0 | 0 | 1 | Most significant column address | | | | Sets the most significant 4 bits of the display RAM column address. | |
| Column address set lower bit | 0 | 1 | 0 | 0 | 0 | 0 | 0 | Least significant column address | | | | Sets the least significant 4 bits of the display RAM column address. | |
| (5) Status read | 0 | 0 | 1 | Status | | | | 0 | 0 | 0 | 0 | 0 | Reads the status data |
| (6) Display data write | 1 | 1 | 0 | Write data | | | | | | | | Writes to the display RAM | |
| (7) Display data read | 1 | 0 | 1 | Read data | | | | | | | | Reads from the display RAM | |
| (8) ADC select | 0 | 1 | 0 | 1 | 0 | 1 | 0 | 0 | 0 | 0 | 0 | 0 | Sets the display RAM address SEG output correspondence 0: normal, 1: reverse |
| (9) Display normal/reverse | 0 | 1 | 0 | 1 | 0 | 1 | 0 | 0 | 1 | 1 | 0 | 1 | Sets the LCD display normal/reverse 0: normal, 1: reverse |
| (10) Display all points ON/OFF | 0 | 1 | 0 | 1 | 0 | 1 | 0 | 0 | 1 | 0 | 0 | 1 | Display all points 0: normal display 1: all points ON |
| (11) LCD bias set | 0 | 1 | 0 | 1 | 0 | 1 | 0 | 0 | 0 | 1 | 0 | 1 | Sets the LCD drive voltage bias ratio 0: 1/9 bias, 1: 1/7 bias (ST7565) |
| (12) Read/modify/write | 0 | 1 | 0 | 1 | 1 | 1 | 0 | 0 | 0 | 0 | 0 | 0 | Column address increment At write: +1 At read: 0 |
| (13) End | 0 | 1 | 0 | 1 | 1 | 1 | 0 | 1 | 1 | 1 | 0 | 0 | Clear read/modify/write |
| (14) Reset | 0 | 1 | 0 | 1 | 1 | 1 | 0 | 0 | 0 | 1 | 0 | 0 | Internal reset |
| (15) Common output mode select | 0 | 1 | 0 | 1 | 1 | 0 | 0 | 0 | 0 | * | * | * | Select COM output scan direction 0: normal direction 1: reverse direction |
| (16) Power control set | 0 | 1 | 0 | 0 | 0 | 1 | 0 | 1 | Operating mode | | | Select internal power supply operating mode | |
| (17) V _s voltage regulator internal resistor ratio set | 0 | 1 | 0 | 0 | 0 | 1 | 0 | 0 | Resistor ratio | | | Select internal resistor ratio(R _b /R _a) mode | |
| (18) Electronic volume mode set | 0 | 1 | 0 | 1 | 0 | 0 | 0 | 0 | 0 | 0 | 0 | 1 | Set the V _s output voltage electronic volume register |
| Electronic volume register set | | | | 0 | 0 | Electronic volume value | | | | | | | |
| (19) Static indicator ON/OFF | 0 | 1 | 0 | 1 | 0 | 1 | 0 | 1 | 1 | 0 | 0 | 0 | 0: OFF, 1: ON |
| Static indicator register set | | | | 0 | 0 | 0 | 0 | 0 | 0 | 0 | 0 | 1 | Set the flashing mode |
| (20) Power saver | | | | | | | | | | | | | Display OFF and display all points ON compound command |
| (21) NOP | 0 | 1 | 0 | 1 | 1 | 1 | 0 | 0 | 0 | 1 | 1 | 1 | Command for non-operation |
| (22) Test | 0 | 1 | 0 | 1 | 1 | 1 | 1 | * | * | * | * | * | Command for IC test. Do not use this command |

Example Initialization Program

```
.....  
Sub Command  
Reset P3.7  
Reset P3.4  
For Writecount = 1 To 8  
Rotate A , Left , 1  
Reset P3.1  
P1 = A  
Set P3.1  
Next Writecount  
Set P3.7  
End Sub  
.....
```

```
Sub Write  
Reset P3.7  
Set P3.4  
For Writecount = 1 To 8  
Rotate A , Left , 1  
Reset P3.1  
P1 = A  
Set P3.1  
Next Writecount  
Set P3.7  
End Sub  
.....
```

```
Sub Init  
Waitms 100  
A = &HA0  
Call Command  
A = &HAE  
Call Command  
A = &HC0  
Call Command  
A = &HA2  
Call Command  
A = &H2F  
Call Command  
A = &H26  
Call Command  
A = &H81  
Call Command  
A = &H11  
Call Command  
A = &HAF  
Call Command  
End Sub  
.....
```

Quality Information

| Test Item | Content of Test | Test Condition | Note |
|---------------------------------------|---|--|------|
| High Temperature storage | Endurance test applying the high storage temperature for a long time. | +80°C , 96hrs | 2 |
| Low Temperature storage | Endurance test applying the low storage temperature for a long time. | -40°C , 96hrs | 1,2 |
| High Temperature Operation | Endurance test applying the electric stress (voltage & current) and the high thermal stress for a long time. | +70°C , 96hrs | 2 |
| Low Temperature Operation | Endurance test applying the electric stress (voltage & current) and the low thermal stress for a long time. | -40°C /-20°C, 96hrs | 1,2 |
| High Temperature / Humidity Operation | Endurance test applying the electric stress (voltage & current) and the high thermal with high humidity stress for a long time. | +50°C , 90% RH , 96hrs | 1,2 |
| Thermal Shock resistance | Endurance test applying the electric stress (voltage & current) during a cycle of low and high thermal stress. | -40°C /-20°C , 60min --> 70°C , 60min = 1 cycle For 10 cycles | |
| Vibration test | Endurance test applying vibration to simulate transportation and use. | 10-50Hz , Acceleration of Gravity:5G 30 min in each of 3 directions X,Y,Z For 15 minutes | 3 |
| Static electricity test | Endurance test applying electric static discharge. | VS= ±4KV, RS=330Ω, CS=150pF For 5 times | |

Note 1: No condensation to be observed.

Note 2: Conducted after 4 hours of storage at 25°C, 0%RH.

Note 3: Test performed on product itself, not inside a container.

Precautions for using LCDs/LCMs

See Precautions at www.newhavendisplay.com/specs/precautions.pdf

Warranty Information and Terms & Conditions

http://www.newhavendisplay.com/index.php?main_page=terms

Mouser Electronics

Authorized Distributor

Click to View Pricing, Inventory, Delivery & Lifecycle Information:

[Newhaven Display:](#)

[NHD-C12864A1Z-FSW-FBW-HTT](#)