

EH-23149-000

SHT 1.1

NOTES:

- 1 A POSITIVE GOING VOLTAGE AT TERMINAL 2, RELATIVE TO TERMINAL 1, CAUSES A DECREASE IN PRESSURE AT THE SOUND OUTLET.
- 2 LOCATED FROM TWO SURFACES FOR CUSTOMER CONVENIENCE. ONLY APPLICABLE FROM ONE SURFACE, NOT TO BE USED TOGETHER. HORIZONTAL LOCATION FOR TERMINAL CENTERED TO $\pm 0,17$ [.007].

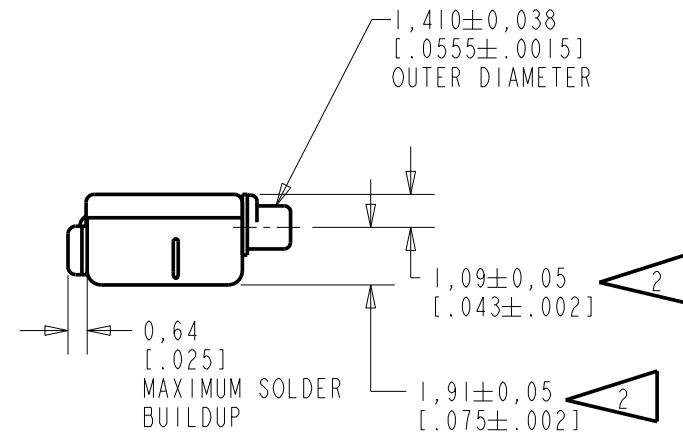
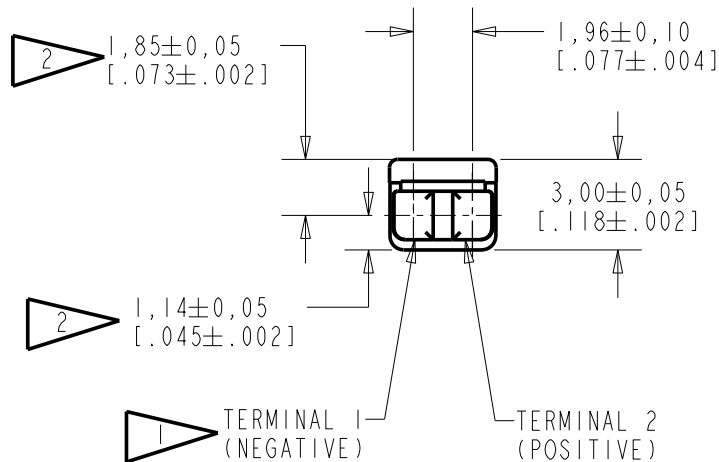
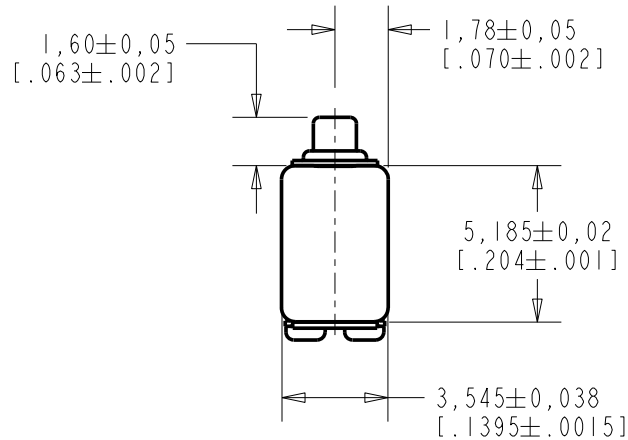

NOMINAL WEIGHT
.23 GRAMS DIMENSIONS IN MILLIMETERS [INCHES]

Revision	C.O. #	Implementation Date	RELEASE LEVEL	REVISION
C	C10109704	5-21-09	Active	C
B	C10108596	12-24-08		
A	C10103366	11-10-05		

SCALE:	4:1	DR. BY	DATE
DO NOT SCALE DRAWING		AB	11-10-05
TITLE:	RECEIVER	GJP	11-21-05
	EH-23149-000	APP. BY	DATE
	OUTLINE DRAWING	GJP	11-21-05
	SHT 1.1		

KNOWLES ELECTRONICS
ITASCA, ILLINOIS U.S.A.

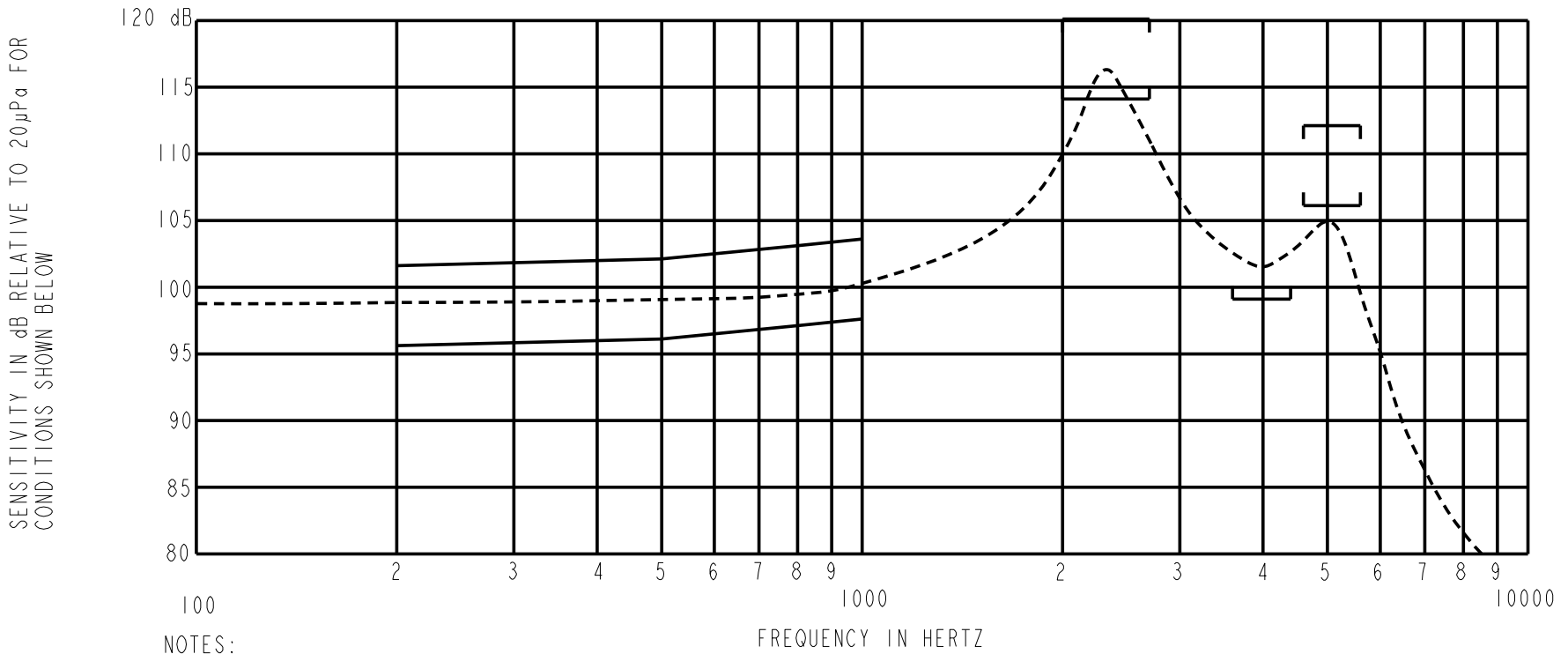

NOTES:

1. MEASUREMENTS MADE USING 10mm (.394") OF 1mm (.039") ID TUBE CONNECTED TO A SIMULATED ANSI S3.3-1960 TYPE HA-3 COUPLER. (T3479 AND B & K DB0138)

FREQUENCY	SENSITIVITY	
	MIN.	MAX.
200	95.5	101.5
500	96.0	102.0
800	96.5	102.5
1000	97.0	103.0
2250-2950	113.5	119.5
3600-4400	101.0	---
4500-5500	106.0	112.0

- RESPONSE, IMPEDANCE, AND DISTORTION MEASUREMENTS MADE USING THE ELECTRICAL TEST CONDITIONS SHOWN BELOW.
- ELECTRICAL SOURCE IMPEDANCE MUST BE GREATER THAN 20 TIMES 1KHz IMPEDANCE FOR TEST CONDITIONS SHOWN BELOW.
- INDIVIDUAL SPECIFICATIONS.

PORT LOCATION	IMPEDANCE OHMS ±15%		DCR @20°C OHMS ±10%	DISTORTION		ELECTRICAL TEST CONDITIONS	
	1KHz	500Hz		MAX. %	FREQ Hz	AC mA RMS	DC mA
12C	165	101	68	10	800	1.63	0.00

Revision	C.O. #	Implementation Date	RELEASE LEVEL	REVISION
C	C10109704	5-21-09	Active	C
B	C10108596	12-24-08		
A	C10103366	11-10-05		

KNOWLES ELECTRONICS
ITASCA, ILLINOIS U.S.A.

WHEN TEST LIMITS ARE USED TO ESTABLISH INCOMING INSPECTION ACCEPTANCE/REJECTION CRITERIA, CORRELATION OF TEST EQUIPMENT WITH KNOWLES IS ALSO REQUIRED FOR ELIMINATION OF EQUIPMENT AND TEST METHOD VARIATION

TITLE: **RECEIVER** **EH-23149-000**
PERFORMANCE SPECIFICATION **SHT 2.1**

DR. BY	DATE
AB	11-10-05
CK. BY	DATE
GJP	11-21-05
APP. BY	DATE
GJP	11-21-05

Mouser Electronics

Authorized Distributor

Click to View Pricing, Inventory, Delivery & Lifecycle Information:

Knowles:

[EH-23043-000](#) [EH-23048-000](#) [EH-23063-000](#) [FEH-29833-I02](#) [EH-23052-000](#) [EH-23053-000](#) [EH-23061-000](#) [FEH-23819-I02](#) [EH-23030-000](#) [EH-23050-000](#) [EH-23149-000](#) [EH-23066-000](#) [FEH-27318-I06](#) [EH-23067-000](#) [EH-23054-000](#) [FEH-26796-I02](#) [EH-23044-000](#) [FEH-26722-I06](#) [FEH-27233-I06](#) [DFG-30445-000](#) [DFG-30852-000](#) [FG-23329-D65](#) [EH-27479-000](#) [EH-26367-000](#) [EH-27418-000](#) [EH-27233-000](#) [DFG-30582-000](#) [FEH-27232-I06](#) [EH-27250-000](#) [EH-30854-000](#) [EH-29833-000](#) [EH-27827-000](#) [EH-27822-000](#) [EH-27374-000](#) [DFG-30581-000](#) [EH-27975-000](#) [EH-27418-111](#) [DFG-30851-000](#) [EH-27157-000](#) [EH-27318-000](#) [EH-27232-000](#) [EH-29921-000](#) [EH-27478-000](#) [EH-27232-111](#)