

## 600mA, 500kHz, Step-Down Switching Regulator in SOT-23

### ■ GENERAL DESCRIPTION

The NJW1933 is a switching regulator IC for buck converter that operates wide input voltage range from 4.5V to 40V. The wide input range makes the NJW1933 suitable for several applications such as 12V and/or 24V industrial supplies, automotive batteries and the other unregulated voltage sources.

It corresponds to Low ESR output capacitor (MLCC), high operating frequency of 500kHz, internally compensated and small SOT-23 package. Therefore, the NJW1933 can realize downsizing of applications with a few and tiny external parts so that adopts current mode control.

Also, it has a soft start function, over current protection and thermal shutdown circuit.

### ■ PACKAGE OUTLINE

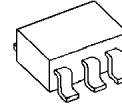

**NJW1933F1**

### ■ FEATURES

- Pin compatible with LT1933 and LT2842. Also it is possible to reduce an external part
- Maximum Rating Input Voltage: 45V
- Wide Operating Voltage Range: 4.5 V to 40V
- Switching Current: 0.8A (min.)
- Fixed Operating Frequency: 500kHz (A-version)
- Uses Tiny Capacitors and Inductors
- Soft Start Function
- Low Shutdown Current < 1 $\mu$ A
- Internally Compensated
- Under Voltage Lockout (UVLO)
- Output Adjustable Down to 1.25V
- Over Current Protection / Thermal Shutdown Protection
- Package Outline: SOT-23-6-1

### ■ PIN CONFIGURATION

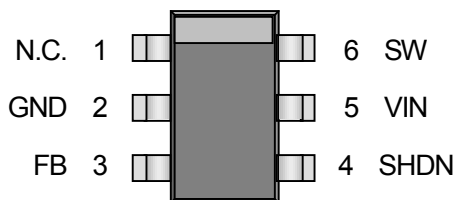

**NJW1933F1**

# NJW1933-T

## PIN DESCRIPTIONS

PIN NAME	PIN NUMBER	FUNCTION
N.C.	1	Unused pin
GND	2	GND pin
FB	3	Output Voltage Detecting pin Connects output voltage through the resistor divider tap to this pin in order to voltage of the FB pin become 1.245V.
SHDN	4	Standby Control pin Normal Operation at the time of High Level. Standby Mode at the time of Low Level or Open.
VIN	5	Power Supply pin for Power Line
SW	6	Switch Output pin of Power MOSFET

## BLOCK DIAGRAM

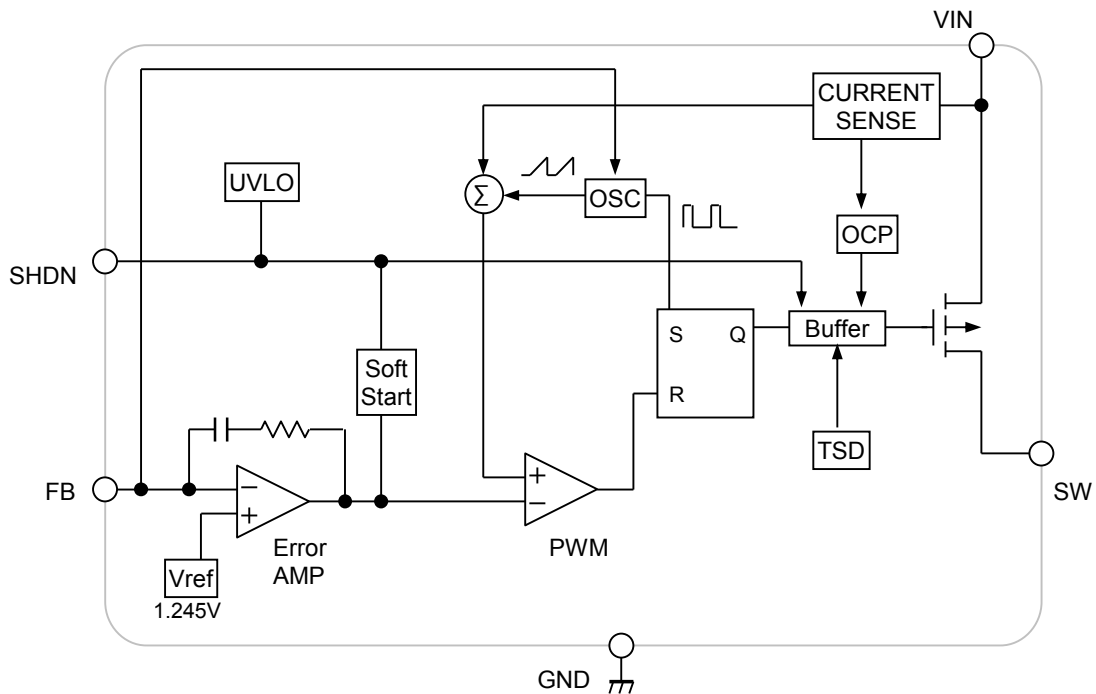

## ■ ABSOLUTE MAXIMUM RATINGS

(Ta=25°C)

PARAMETER	SYMBOL	RATINGS	UNIT
Input Voltage	V <sub>IN</sub>	-0.3 to +45	V
VIN-SW pin voltage	V <sub>V-SW</sub>	-0.3 to +45	V
SHDN Voltage	V <sub>SHDN</sub>	-0.3 to +45	V
Feedback Pin Voltage	V <sub>FB</sub>	-0.3 to +6	V
Power Dissipation	P <sub>D</sub>	510 (*1) 710 (*2)	mW
Junction Temperature	T <sub>j</sub>	-40 to +150	°C
Operating Temperature	T <sub>opr</sub>	-40 to +105	°C
Storage Temperature	T <sub>stg</sub>	-50 to +150	°C

(\*1): Mounted on glass epoxy board. (76.2×114.3×1.6mm:based on EIA/JDEC standard, 2Layers)

(\*2): Mounted on glass epoxy board. (76.2×114.3×1.6mm:based on EIA/JDEC standard, 4Layers),

internal Cu area: 74.2×74.2mm

## ■ RECOMMENDED OPERATING CONDITION

(Ta=25°C)

PARAMETER	SYMBOL	MIN.	TYP.	MAX.	UNIT
Input Voltage	V <sub>IN</sub>	4.5	—	40	V

# NJW1933-T

## ■ ELECTRICAL CHARACTERISTICS

(Specifications in standard type face are for  $T_a=+25^{\circ}\text{C}$  and those with boldface type apply over the below Operating Temperature Range ( $T_a=-40^{\circ}\text{C}$  to  $+105^{\circ}\text{C}$ ). Minimum and Maximum specs are guaranteed through test. Unless otherwise noted,  $V_{IN}=V_{SHDN}=12\text{V}$ ,  $T_a=+25^{\circ}\text{C}$ )

PARAMETER	SYMBOL	CONDITIONS	MIN.	TYP.	MAX.	UNIT
-----------	--------	------------	------	------	------	------

### Under Voltage Lockout Block

ON Threshold Voltage	$V_{T\_ON}$	$V_{IN} = L \rightarrow H$	4.2	4.35	4.5	V
OFF Threshold Voltage	$V_{T\_OFF}$	$V_{IN} = H \rightarrow L$	4.1	4.25	4.4	V
Hysteresis Width	$V_{HYS}$		–	100	–	mV

### Oscillation Block

Oscillation Frequency1	$f_{OSC1}$	$V_{FB}=1.1\text{V}$	400	500	600	kHz
Oscillation Frequency2	$f_{OSC2}$	$V_{FB}=0\text{V}$	–	80	–	kHz

### Error Amplifier Block

Feedback Voltage	$V_B$		<b>-1.6%</b>	1.245	<b>+1.6%</b>	V
FB Pin Bias Current	$I_B$	$V_{FB}=1.3\text{V}$	–	10	<b>100</b>	nA

### PWM Comparator Block

Maximum Duty Cycle	$M_{AX}D_{UTY}$	$V_{FB}=1.1\text{V}$	<b>88</b>	94	–	%
Minimum ON Time	$t_{ON\_min}$		–	100	160	ns

### Output Block

Switching Current Limit	$I_{LIM}$		0.8	1.1	1.5	A
Output ON Resistance	$R_{ON}$	$I_{SW}=400\text{mA}$	–	1	1.6	$\Omega$
Switch Leakage Current	$I_{LEAK}$	$V_{SHDN} = 0\text{V}$ , $V_{IN}=45\text{V}$ , $V_{SW}=0\text{V}$	–	–	1	$\mu\text{A}$

### SHDN Block

SHDN ON Control Voltage	$V_{SHDN(ON)}$	$V_{SHDN} = L \rightarrow H$	2.3	–	$V_{IN}$	V
SHDN OFF Control Voltage	$V_{SHDN(OFF)}$	$V_{SHDN} = H \rightarrow L$	0	–	0.3	V
SHDN Bias Current1	$I_{SHDN\_BIAS1}$	$V_{SHDN} = 2.3\text{V}$	–	5	10	$\mu\text{A}$
SHDN Bias Current2	$I_{SHDN\_BIAS2}$	$V_{SHDN} = 0\text{V}$	–	0.01	0.1	$\mu\text{A}$

### General

Quiescent Current1	$I_{DD1}$	Not Switching, $V_{FB}=1.3\text{V}$	–	1.6	2.5	mA
Quiescent Current2	$I_{DD2}$	No Load, $V_{FB}=1.1\text{V}$	–	2.2	3.2	mA
Quiescent Current in SHDN	$I_{DD\_SHDN}$	$V_{SHDN} = 0\text{V}$	–	–	1	$\mu\text{A}$

## ■ THERMAL CHARACTERISTICS

PARAMETER	SYMBOL	VALUE	UNIT
Junction-to-ambient thermal resistance	$\theta_{ja}$	245 (*3)	°C/W
		175 (*4)	
Junction-to-Top of package characterization parameter	$\psi_{jt}$	70 (*3)	°C/W
		60 (*4)	

(\*3): Mounted on glass epoxy board. (76.2×114.3×1.6mm:based on EIA/JDEC standard, 2Layers)

(\*4): Mounted on glass epoxy board. (76.2×114.3×1.6mm:based on EIA/JDEC standard, 4Layers),

internal Cu area: 74.2×74.2mm

## ■ POWER DISSIPATION vs. AMBIENT TEMPERATURE

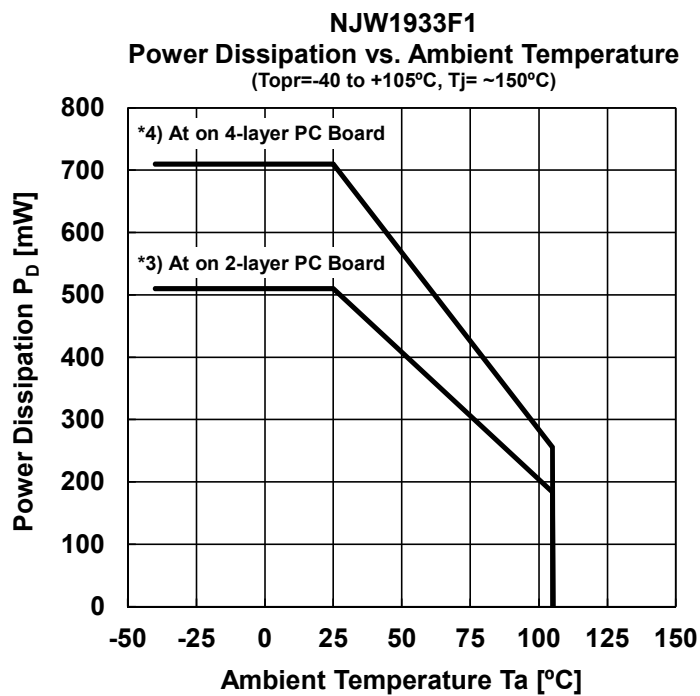

# NJW1933-T

## ■ TYPICAL APPLICATIONS

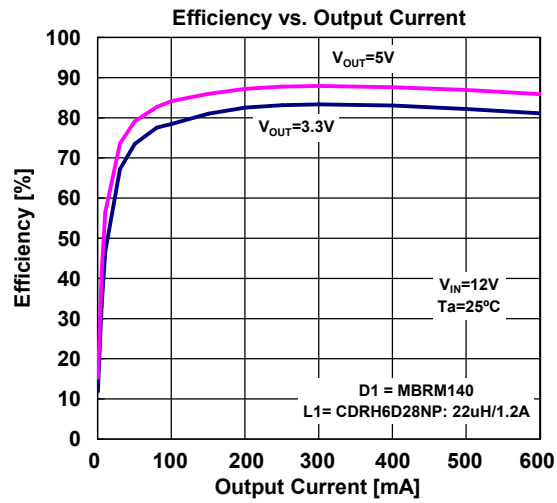
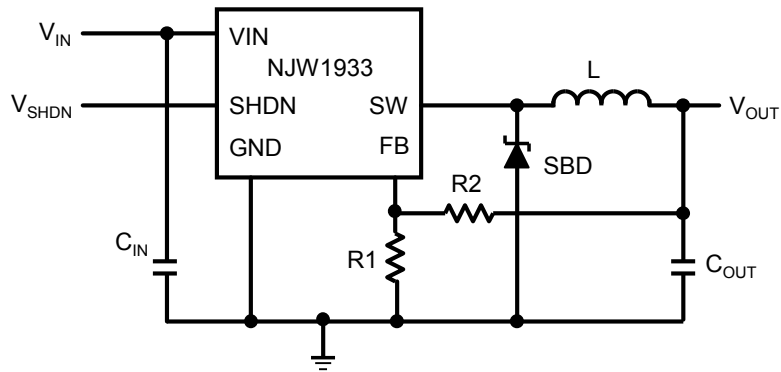

## ■ TYPICAL CHARACTERISTICS

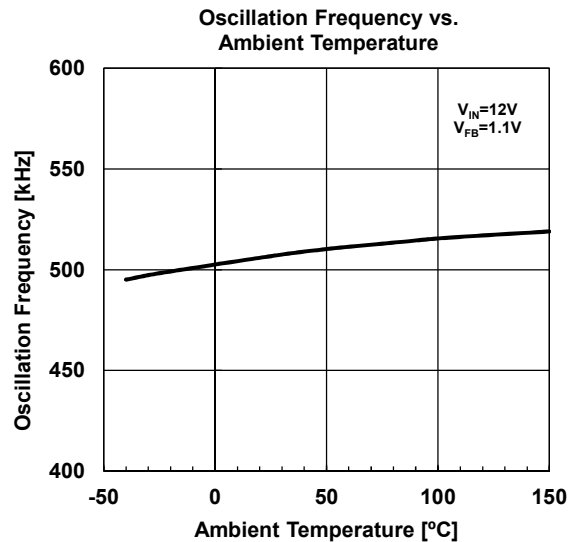
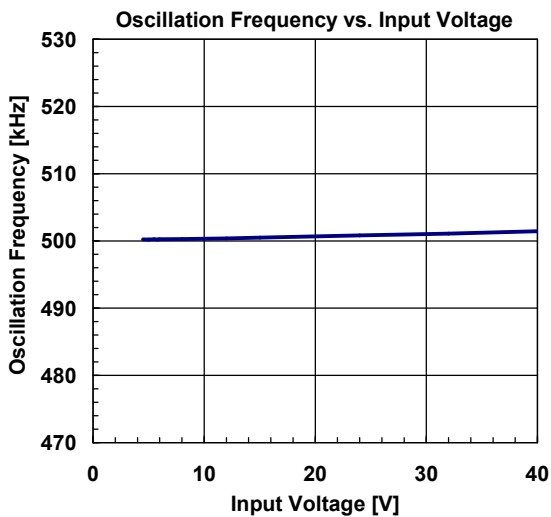
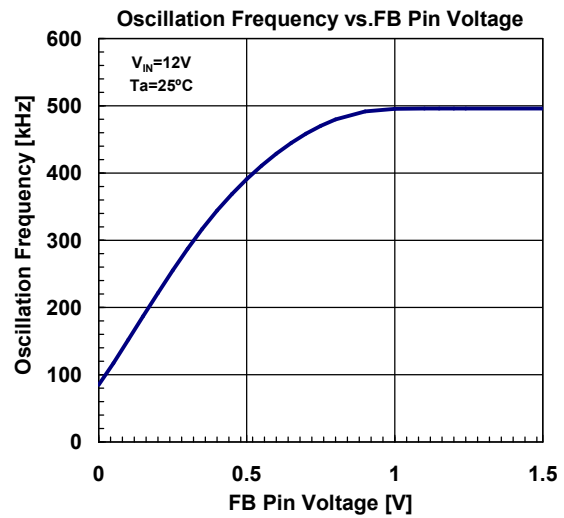
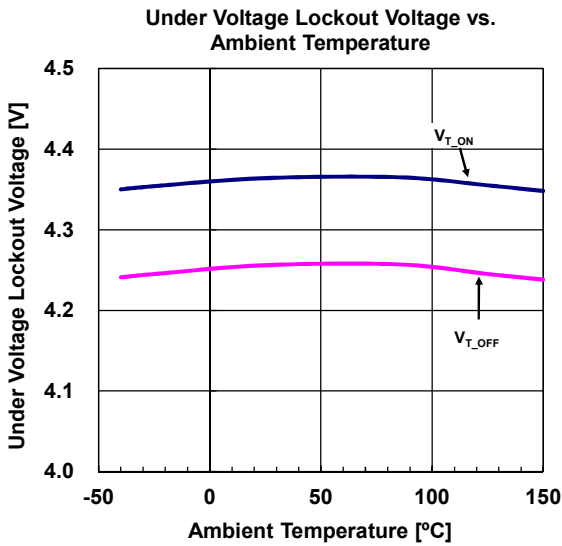
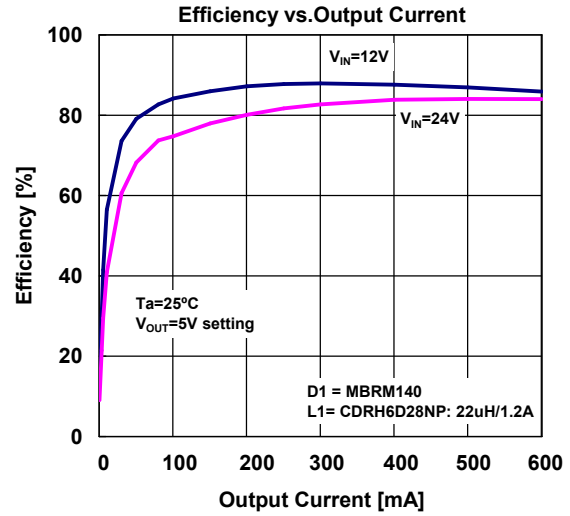
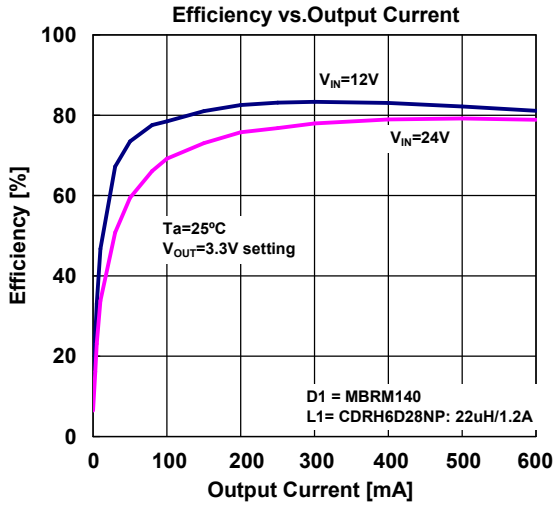

# NJW1933-T

## TYPICAL CHARACTERISTICS

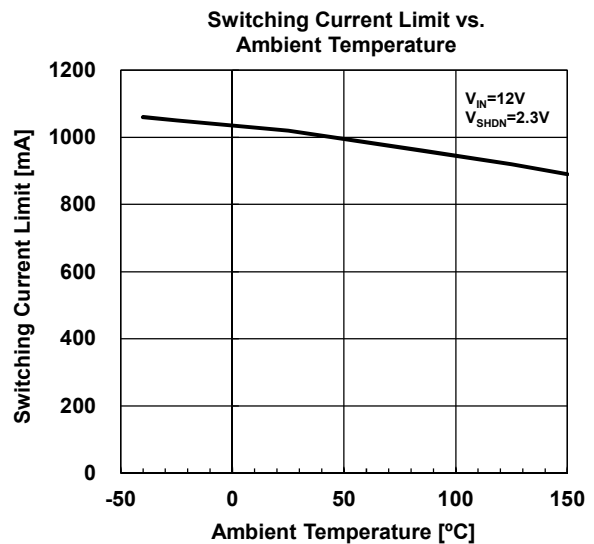
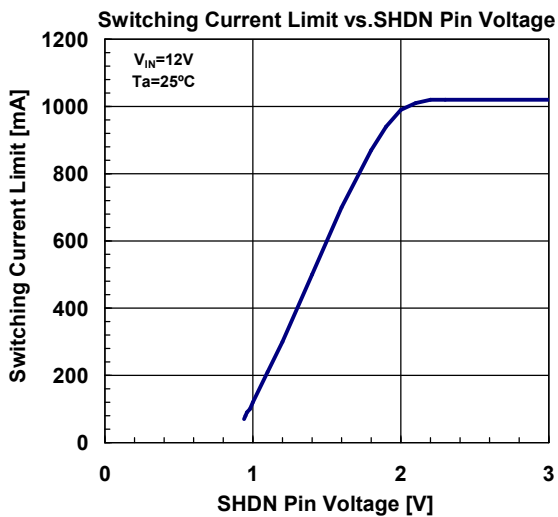
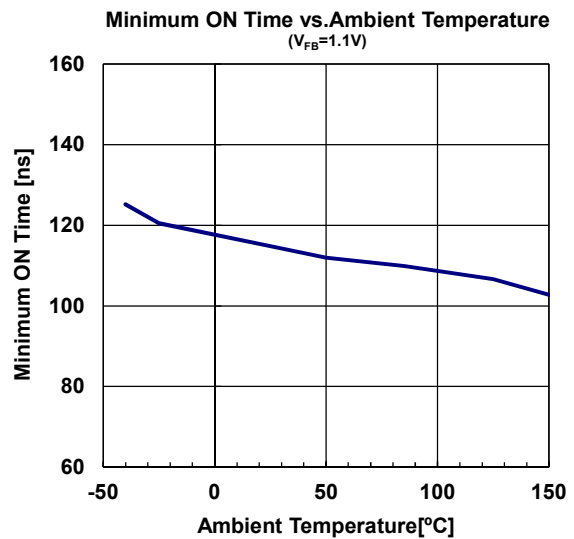
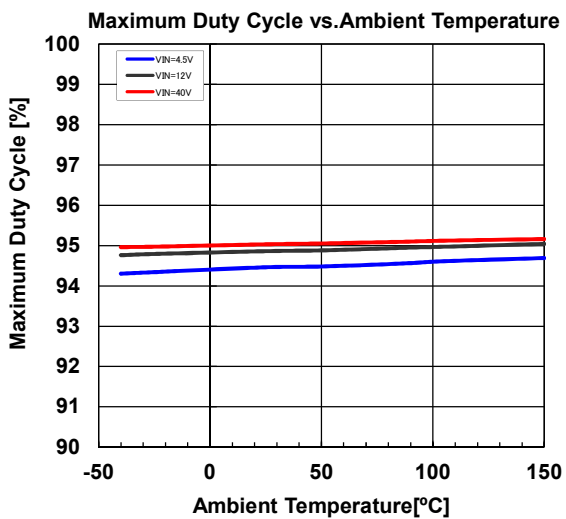
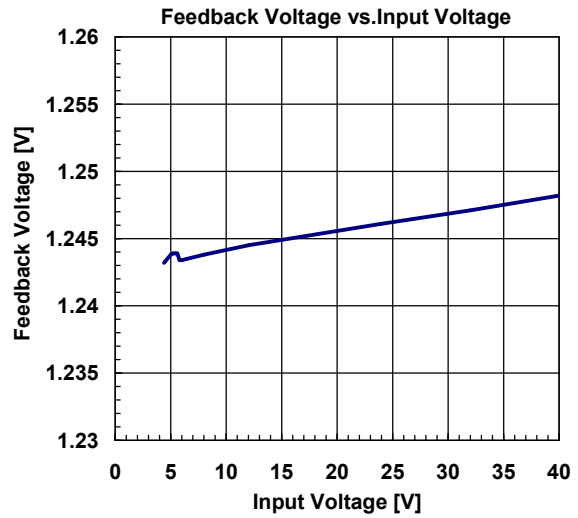
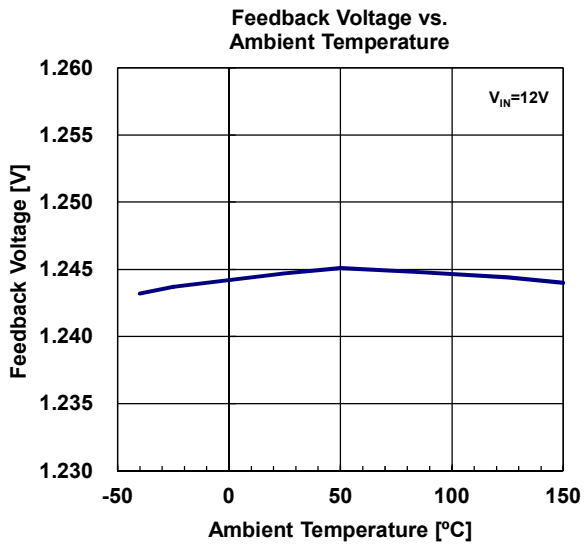



## ■ TYPICAL CHARACTERISTICS

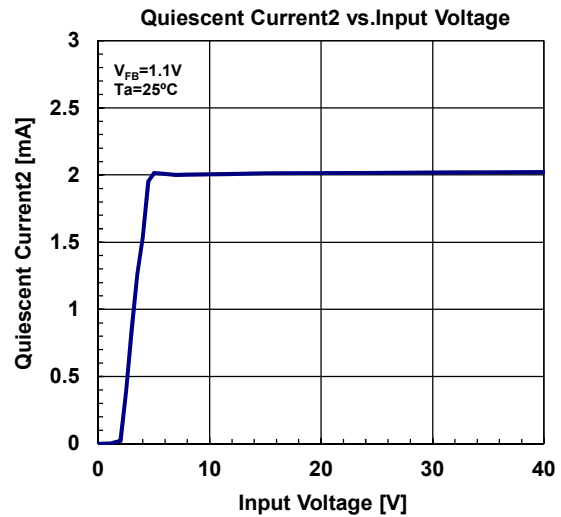
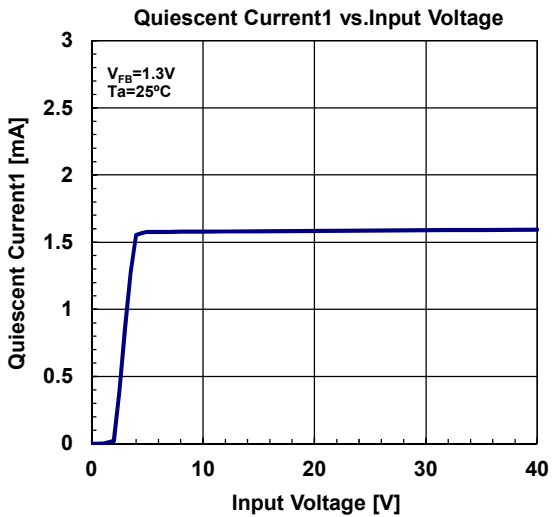
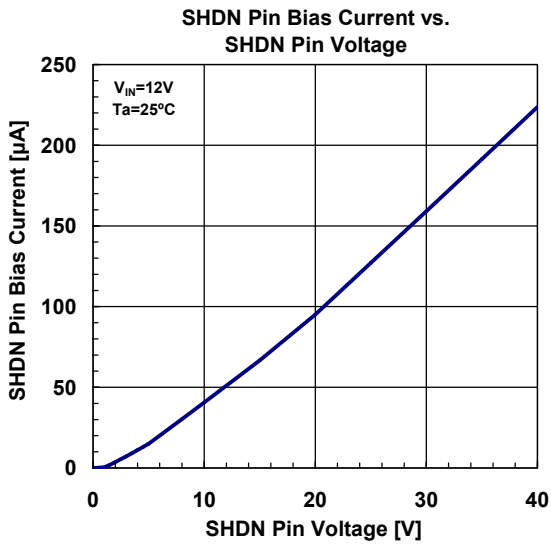
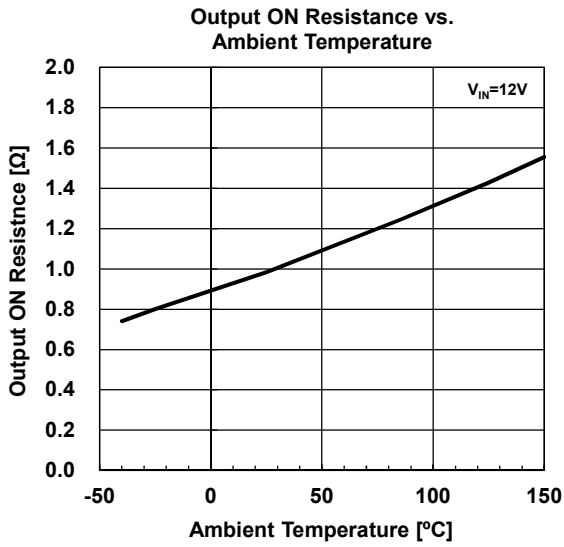

### ■ Description of Block Features

#### 1. Basic Functions / Features

- Error Amplifier Section (ER-AMP)

1.245V±1.6% (Ta= -40°C to +105°C) precise reference voltage is connected to the non-inverted input of this section. To set the output voltage, connects converter's output to inverted input of this section (FB pin). If requiring output voltage of more than 1.245V, should insert resistor divider. Because the optimized compensation circuit is built-in, the application circuit can be composed of minimum external parts.

- PWM Comparator Section (PWM), Oscillation Circuit Section (OSC)

The NJW1933 is a constant frequency, current mode step down regulator. The oscillation frequency is 500kHz (typ.) (A-version). The PWM signal is output by feedback of output voltage and slope compensation switching current at the PWM comparator block. The maximum duty ratio is 94% (typ.).

Table1. Minimum ON time of NJW1933

Product Name	NJW1933F1-AT (f <sub>OSC</sub> =500kHz)
Minimum ON-time	100ns (typ.)

The ON time of buck converter is decided with the following equation.

$$t_{on} = \frac{V_{OUT}}{V_{IN} \times f_{OSC}} [s]$$

V<sub>IN</sub> means the input voltage and V<sub>OUT</sub> means the output voltage.

When the ON time becomes below t<sub>ON-min</sub>, in order to maintain the stable output voltage, change of duty or pulse skip operation may be performed.

- Power MOSFET (SW Output Section)

The power is stored in the inductor by the switch operation of built-in power MOSFET. The output current is limited to 0.8A (min.) the overcurrent protection function. In case of step-down converter, the forward direction bias voltage is generated with inductance current that flows into the external regenerative diode when MOSFET is turned off.

The SW pin allows voltage between the VIN pin and the SW pin up to +45V. However, you should use an Schottky diode that has low saturation voltage.

- Power Supply, GND pin (VIN and GND)

Along with switching element drive according to oscillation frequency, a transient current flows into the NJW1933. If the power supply impedance of the power supply circuit is large the input voltage fluctuation occurs. As the result, it will not be possible to take sufficient advantage of the NJW1933 performance.

Therefore, you should insert a bypass capacitor close to the VIN pin and the GND pin in order to lower high frequency impedance.

### ■ Description of Block Features (Continued)

#### 2. Additional and Protection Functions / Features

- Under Voltage Lockout (UVLO)

The NJW1933 includes an undervoltage lockout to prevent switching when  $V_{IN}$  is less than 4.35V (typ.). The NJW1933 has 100mV (typ.) width hysteresis voltage at rise and decay of power supply voltage. The hysteresis prevents the malfunction at the time of UVLO operating and releasing.

- Soft Start Function (Soft Start)

The SHDN pin can be used to soft-start the NJW1933, reducing the maximum input current during start up. The SHDN pin is driven through an external RC filter to create a voltage ramp at this pin. By adjusting the RC time constant, the peak start up current can be reduced to the current that is required to regulate the output, with no overshoot. And the soft-start operation is able to adjust, too. Moreover, the switching current limit value is limited by applied voltage to the SHDN pin. When the applying voltage is 2.3V,  $I_{LIM}$  becomes maximum spec.

(Refer to "Switching Current Limit vs.SHDN Pin Voltage" characteristics on ELECTRICAL CHARACTERISTICS)

Choose the value of the resistor so that it can supply 20 $\mu$ A or more when the SHDN pin reaches 2.3V.

### ■ Description of Block Features (Continued)

#### ● Over Current Protection Circuit (OCP)

The NJW1933 contains overcurrent protection circuit. The overcurrent protection circuit is able to decrease heat generation at the overload. The NJW1933 output returns automatically along with release of the over current condition. At when the switching current becomes  $I_{LIM}$  or more, the overcurrent protection circuit is stopped the MOSFET output. Then at next switching period, the switching operation is returned. The oscillator reduces the NJW1933's operating frequency when the voltage at the FB pin is low. This frequency foldback helps to control the output current during startup and overload by decreasing minimum ON Duty.

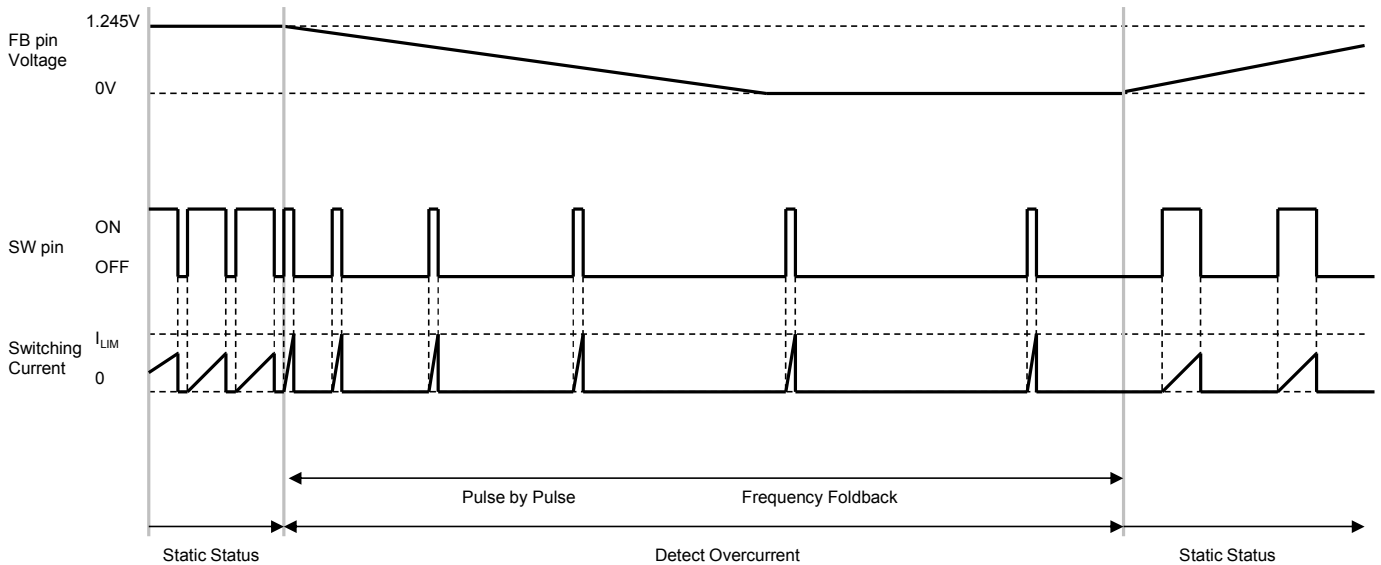

Fig. 1. Timing Chart at Over Current Detection

#### ● Thermal Shutdown Function (TSD)

When Junction temperature of the NJW1933 exceeds the  $175^{\circ}\text{C}^*$ , internal thermal shutdown circuit function stops SW function. When junction temperature decreases to  $145^{\circ}\text{C}^*$  or less, SW operation returns with soft start operation.

The purpose of this function is to prevent malfunctioning of IC at the high junction temperature. Therefore it is not something that urges positive use. You should make sure to operate within the junction temperature range rated ( $\sim 150^{\circ}\text{C}$ ). (\* Design value)

#### ● Standby Function

The SHDN pin is used to place the NJW1933 in shutdown, disconnecting the output and reducing the input current to less than  $1\mu\text{A}$ . The NJW1933 stops the operating and becomes standby status when the SHDN pin becomes less than  $0.3\text{V}$  or OPEN. You should connect to the VIN pin when you do not use standby function.

### ■ Application Information

#### ● Inductors

Because a large current flows to the inductor, you should select the inductor with the large current capacity not to saturate. Optimized inductor value is determined by the input voltage and output voltage.

The Inductor setting example is shown in Table 2.

When increasing inductor value, it is necessary to increasing capacity of an output capacitor and to secure the stability of application. The minimum of inductor value is restricted from the following equation, when ON duty exceeds 50%.

$$L \geq \frac{V_{IN} \times (2 \times D_{ON} - 1)}{0.4} [\mu\text{H}]$$

Reducing L decreases the size of the inductor. However a peak current increases and adversely affects the efficiency. (Fig.2)

Moreover, you should be aware that the output current is limited because it becomes easy to operating to the overcurrent limit.

The peak current is decided the following equation.

$$\Delta I_L = \frac{(V_{IN} - V_{OUT}) \times V_{OUT}}{L \times V_{IN} \times f_{OSC}} [\text{A}]$$

$$I_{pk} = I_{OUT} + \frac{\Delta I_L}{2} [\text{A}]$$

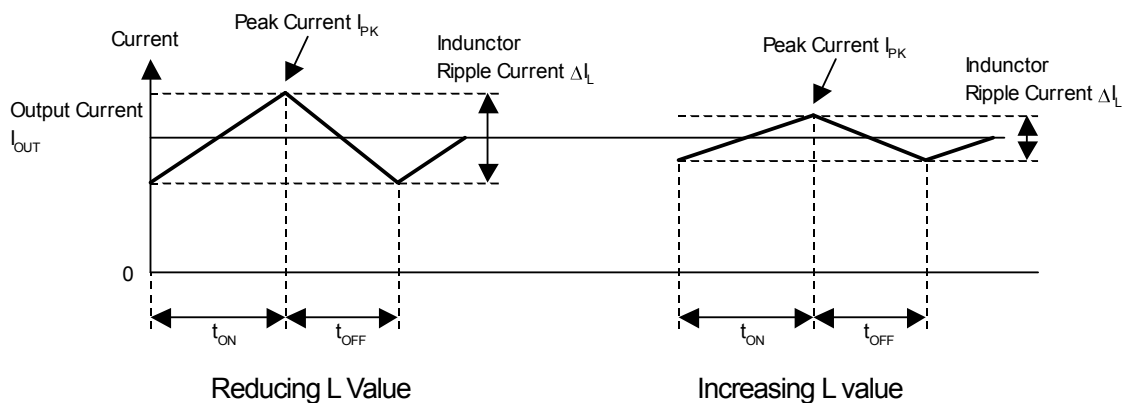

Fig.2 Inductor Current State Transition (Continuous Conduction Mode)

### ■ Application Information (Continued)

#### ● Input Capacitor

Transient current flows into the input section of a switching regulator responsive to frequency. If the power supply impedance of the power supply circuit is large the input voltage fluctuation occurs. As the result, it will not be possible to take sufficient advantage of the NJW1933 performance. Therefore insert an input capacitor as close to the MOSFET as possible. A ceramic capacitor is the optimal for input capacitor.

The effective input current can be expressed by the following equation.

$$I_{RMS} = I_{OUT} \times \frac{\sqrt{V_{OUT} \times (V_{IN} - V_{OUT})}}{V_{IN}} [A]$$

In the above equation, the maximum current is obtained when  $V_{IN} = 2 \times V_{OUT}$ , and the result in this case is  $I_{RMS} = I_{OUT(MAX)} \div 2$ .

When selecting the input capacitor, carry out an evaluation based on the application, and should use a capacitor that has adequate margin.

#### ● Output Capacitor

An output capacitor stores power from the inductor and stabilizes the voltage provided to the output.

Because the NJW1933 corresponds to the output capacitor of low ESR the ceramic capacitor is the optimal for compensation. Table.2 shown the output capacitor setting example.

Table2 Output Capacitor Setting Example

Input Voltage $V_{IN}$	Output Voltage $V_{OUT}$	Inductor $L$	Output Capacitor $C_{OUT}$	Part Number
12V	3.3V	22 $\mu$ H	$\geq 22\mu F \times 2 / 6.3V$	GRM31CB30J226ME18: Murata
	5.0V	22 $\mu$ H	$\geq 47\mu F / 6.3V$	GRM31CB30J476KE18: Murata
	8.0V	22 $\mu$ H	$\geq 22\mu F / 25V$	GRM32EB31E226KE15: Murata
24V	3.3V	22 $\mu$ H	$\geq 22\mu F \times 2 / 6.3V$	GRM31CB30J226ME18: Murata
	5.0V	33 $\mu$ H	$\geq 47\mu F / 6.3V$	GRM31CB30J476KE18: Murata
	8.0V	47 $\mu$ H	$\geq 22\mu F / 25V$	GRM32EB31E226KE15: Murata

To consider using output capacitor capacity bigger than Table2.

In addition, you should consider varied characteristics of capacitor (a frequency characteristic, a temperature characteristic, a DC bias characteristic and so on) and unevenness peculiar to a capacitor supplier enough. Therefore when selecting a capacitors, you should confirm the characteristics with supplier datasheets.

When selecting an output capacitor, you must consider Equivalent Series Resistance (ESR) characteristics, ripple current, and breakdown voltage. If using low ESR type capacitors, it is possible to reduce the ripple voltage.

The output ripple noise can be expressed by the following equation.

$$V_{\text{ripple}(p-p)} = ESR \times \Delta I_L [V]$$

The effective ripple current that flows in a capacitor ( $I_{rms}$ ) is obtained by the following equation.

$$I_{rms} = \frac{\Delta I_L}{2\sqrt{3}} [Arms]$$

### ■ Application Information (Continued)

#### ● Catch Diode

When the switch element is in OFF cycle, the stored power in the inductor flows via the catch diode to the output capacitor. Therefore during each cycle the current flows to the diode in response to load current. Because a diode forward saturation voltage and current accumulation are cause of power loss, a Schottky Barrier Diode (SBD), that has a low forward saturation voltage is ideal. An SBD also has a short reverse recovery time. If the reverse recovery time is long, shoot through current flows when the switching transistor transitions from OFF cycle to ON cycle. This current may lower efficiency and affect such factors as noise generation.

#### ● Setting Output Voltage, Compensation Capacitor

The output voltage  $V_{OUT}$  is determined by the relative resistances of R1/R2. The current that flows in R1/R2 must be a value that can ignore the bias current that flows in Error AMP.

$$V_{OUT} = \left( \frac{R2}{R1} + 1 \right) \times V_B \text{ [V]}$$

The zero points are formed by parallel addition CFB to R2, and it can improve the phase compensation of the NJW1933

The zero point is decided the following equation.

$$f_{z1} = \frac{1}{2 \times \pi \times R2 \times C_{FB}} \text{ [Hz]}$$

You should set the zero point as a guide from 40kHz to 70kHz.

### ■ Application Information (Continued)

#### ● Board Layout

In the switching regulator application, because the current flow corresponds to the oscillation frequency, the substrate (PCB) layout becomes an important.

You should attempt the transition voltage decrease by making a current loop area minimize as much as possible. Therefore, you should make a current flowing line thick and short as much as possible. Fig.3. shows a current loop at step-down converter. Especially, should lay out high priority the loop of  $C_{IN}$ -SW-SBD that occurs rapid current change in the switching. It is effective in reducing noise spikes caused by parasitic inductance.

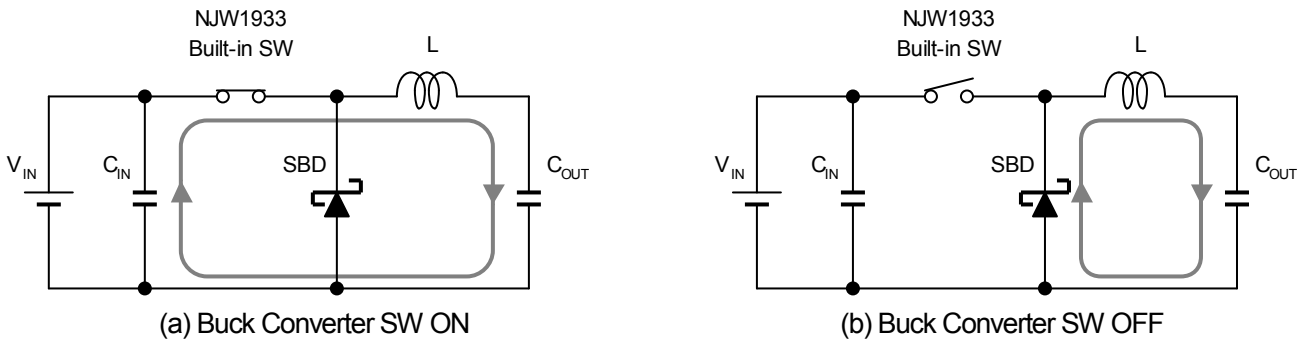

Fig.3 Current Loop at Buck Converter

Concerning the GND line, it is preferred to separate the power system and the signal system, and use single ground point. The voltage sensing feedback line should be as far away as possible from the inductance. Because this line has high impedance, it is laid out to avoid the influence noise caused by flux leaked from the inductance.

Fig.4 shows example of wiring at buck converter. Fig.5 shows the PCB layout example.

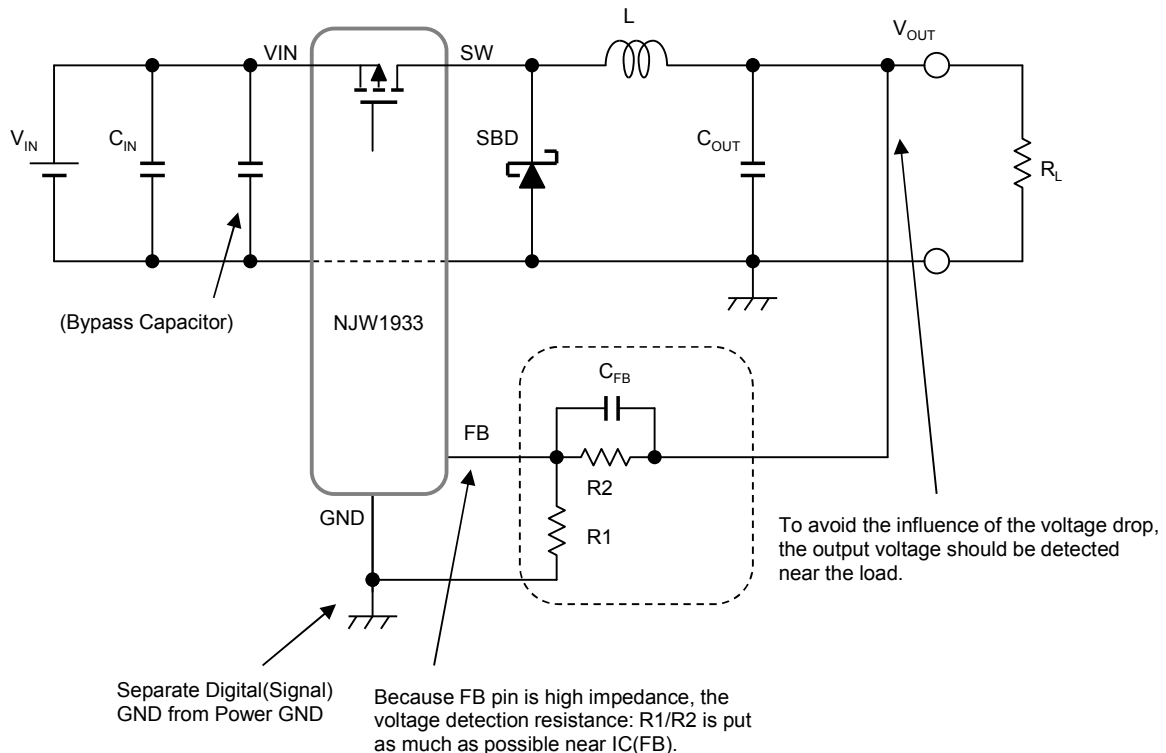
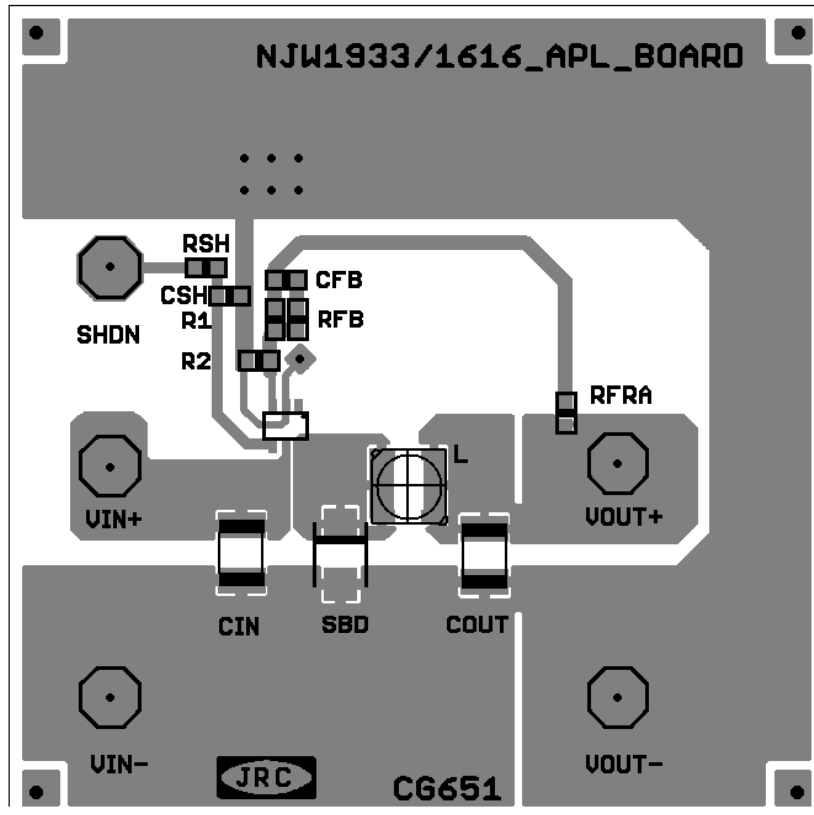

Fig.4 Board Layout at Buck Converter



### ■ Application Information (Continued)



Connect Signal GND line and Power GND line on backside pattern

Fig.5 Layout Example (upper view)

### ■ Calculation of Power Dissipation

A lot of the power consumption of buck converter occurs from the internal switching element (Power MOSFET). Power consumption of NJW1933 is roughly estimated as follows.

$$\begin{aligned} \text{Input Power:} & \quad P_{\text{IN}} = V_{\text{IN}} \times I_{\text{IN}} \quad [\text{W}] \\ \text{Output Power:} & \quad P_{\text{OUT}} = V_{\text{OUT}} \times I_{\text{OUT}} \quad [\text{W}] \\ \text{Diode Loss:} & \quad P_{\text{DIODE}} = V_{\text{F}} \times I_{\text{L(avg)}} \times \text{OFF duty} \quad [\text{W}] \\ \text{NJW1933 Power Consumption:} & \quad P_{\text{LOSS}} = P_{\text{IN}} - P_{\text{OUT}} - P_{\text{DIODE}} \quad [\text{W}] \end{aligned}$$

Where:

$V_{\text{IN}}$	: Input Voltage for Converter	$I_{\text{IN}}$	: Input Current for Converter
$V_{\text{OUT}}$	: Output Voltage of Converter	$I_{\text{OUT}}$	: Output Current of Converter
$V_{\text{F}}$	: Diode's Forward Saturation Voltage	$I_{\text{L(avg)}}$	: Inductor Average Current
OFF duty	: Switch OFF Duty		

The efficiency ( $\eta$ ) is calculated the following equation.

$$\eta = (P_{\text{OUT}} \div P_{\text{IN}}) \times 100 \quad [\%]$$

You should consider temperature derating to the calculated power consumption:  $P_{\text{D}}$ .

You should design power consumption in rated range referring to the Power Dissipation vs. Ambient Temperature characteristics.

### ■ APPLICATION EXAMPLE

#### ● Buck Converter Specification

IC : NJW1933F1-AT  
 Input Voltage :  $V_{IN}=12V$   
 Output Voltage :  $V_{OUT}=3.3V$   
 Output Current :  $I_{OUT}=0.6A$   
 Oscillation Frequency :  $f_{osc}=500kHz$

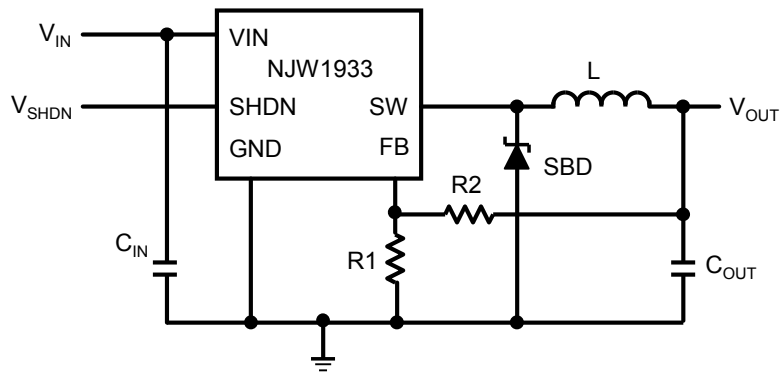

SYMBOL	QTY.	PART NUMBER	DESCRIPTION	MFR.
IC	1	NJW1933F1-AT	0.6A MOSFET built-in SW.REG IC	New JRC
L	1	CDRH6D28NP-220NC	Inductor 22 $\mu$ H, 1.2A	Sumida
SBD	1	MBRM140T3G	Schottky Diode 40V, 1A	ON Semiconductor
$C_{IN1}$	1	GRM31CB31H225KA87	Ceramic Capacitor 3216 2.2 $\mu$ F, 50V, B	Murata
$C_{OUT}$	1	GRM32EB31C476ME15	Ceramic Capacitor 3225 47 $\mu$ F, 16V, B	Murata
R1	1	3.3k $\Omega$	Resistor 1608 3.3k $\Omega$ , $\pm 1\%$ , 0.1W	Std.
R2	1	5.6k $\Omega$	Resistor 1608 5.6k $\Omega$ , $\pm 1\%$ , 0.1W	Std.

### ■ APPLICATION EXAMPLE

#### ● Buck Converter Specification

IC : NJW1933F1-AT  
 Input Voltage :  $V_{IN}=12V$   
 Output Voltage :  $V_{OUT}=5V$   
 Output Current :  $I_{OUT}=0.6A$   
 Oscillation Frequency :  $f_{osc}=500kHz$

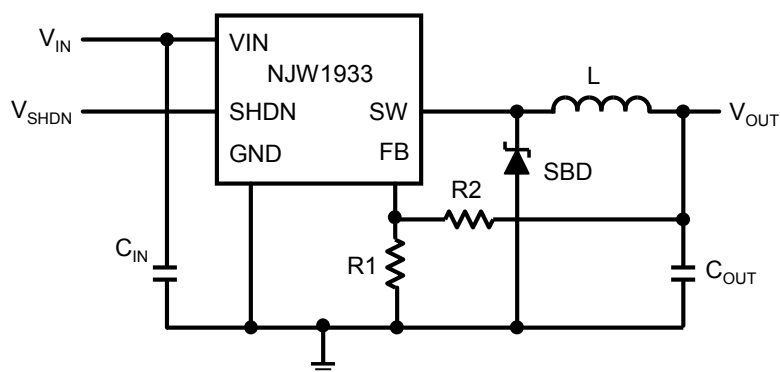

SYMBOL	QTY	PART NUMBER	DESCRIPTION	MFR
IC	1	NJW1933F1-AT	0.6A MOSFET built-in SW.REG IC	New JRC
L	1	CDRH6D28NP-220NC	Inductor 22 $\mu$ H, 1.2A	Sumida
SBD	1	MBRM140T3G	Schottky Diode 40V, 1A	ON Semiconductor
$C_{IN1}$	1	GRM31CB31H225KA87	Ceramic Capacitor 3216 2.2 $\mu$ F, 50V, B	Murata
$C_{OUT}$	1	GRM32EB31C476ME15	Ceramic Capacitor 3225 47 $\mu$ F, 16V, B	Murata
R1	1	3.9k $\Omega$	Resistor 1608 3.9k $\Omega$ , $\pm 1\%$ , 0.1W	Std.
R2	1	12k $\Omega$	Resistor 1608 12k $\Omega$ , $\pm 1\%$ , 0.1W	Std.

## PACKAGE OUT LINE

### SOT-23-6-1

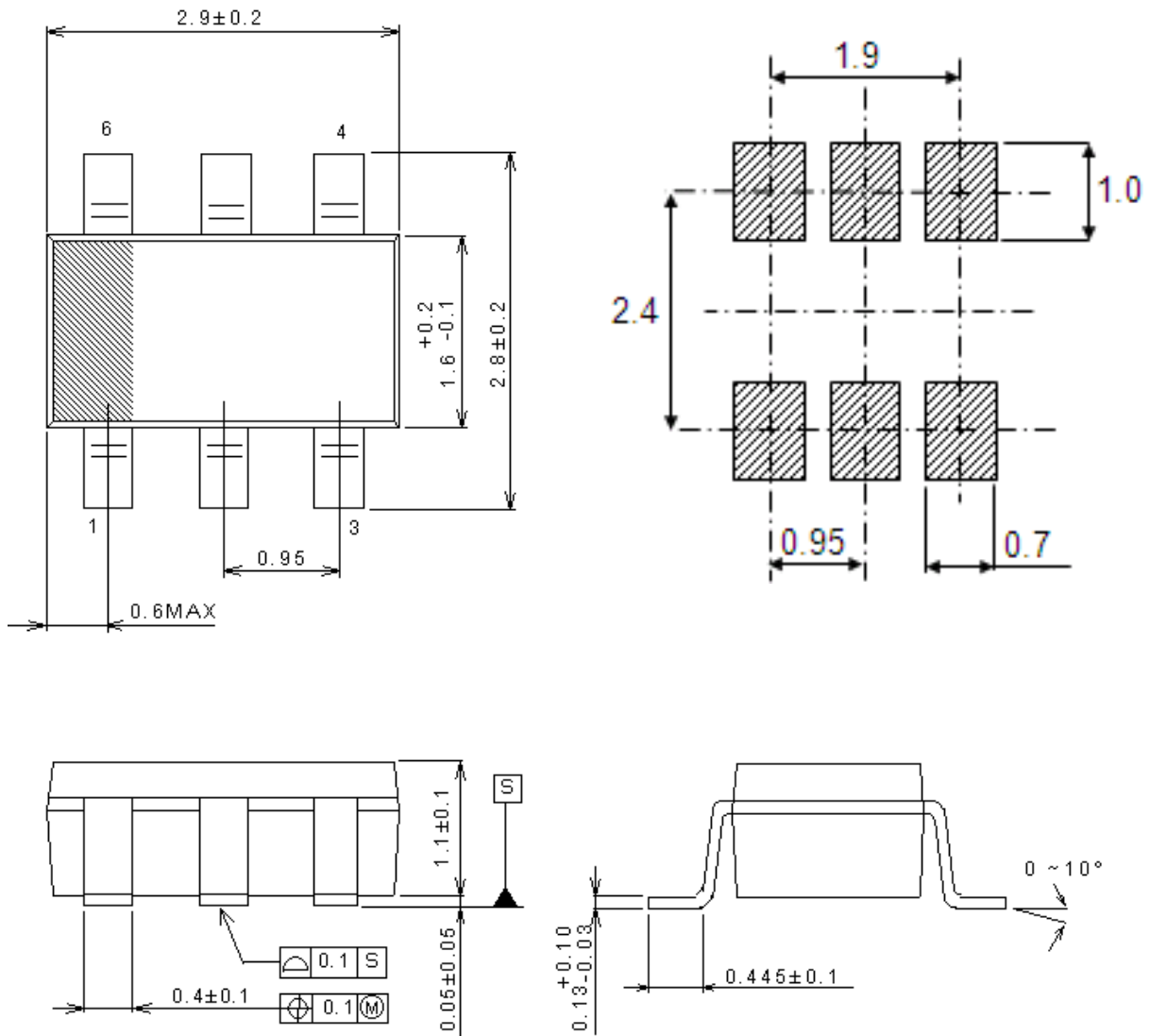

## NOTES

All linear dimensions are in millimeters.

This drawing is subject to change without notice.

### [CAUTION]

The specifications on this databook are only given for information, without any guarantee as regards either mistakes or omissions. The application circuits in this databook are described only to show representative usages of the product and not intended for the guarantee or permission of any right including the industrial rights. All other trademarks mentioned herein are property of their respective companies.

# Mouser Electronics

Authorized Distributor

Click to View Pricing, Inventory, Delivery & Lifecycle Information:

[NJR:](#)

[NJW1933F1-AT-TE2](#)