

RECOMMENDED MATING PIN DESIGN

REFER TO SPECIFIC PIN DRAWING FOR COMPLETE REQUIREMENTS (I.E. MATERIAL, PLATING, DIMENSIONS, ETC)

SYMBOL DEFINITION		MISSING SYMBOLS	
A DIMENSION WITHOUT AN INSPECTION REPORT SYMBOL DOES NOT REQUIRE INSPECTION. IT MAY BE CONTROLLED ON THE INDIVIDUAL COMPONENT DRAWING.	TOTAL NO OF INSPECTIONS REQUIRED	1 - 3	24
	LAST NO. USED		20

DATE	STG	REV	N/P	CHG	ZONE	REVISION HISTORY	AUTH	DR	APVD 1	APVD 2
30AU02	R	01	-	-		15445904 & 15445905 - RELEASED	228663	GLG	JVM	ADK
17FE03	R	02	-	-		ALL PARTS - REVISED	236064	JVM	JVM	ADK
25JN03	R	03	-	-		ALL PARTS - REVISED GRAPHICS, 0.49 ±0.05 WAS 0.45 ±0.05 AND 2X 1.8 ±0.075 WAS 1.8 ±0.075	242577	JAA	JAA	ADK
09OC03	R	04	-	-		ALL PARTS - REVISED GRAPHICS, REVISED NOTE #3 AND UPDATED PDM ATTRIBUTES	247214	EES	EES	AD
06N003	R	05	-	-		ALL PARTS - REVISED NOTES; REMOVED SYMBOLS 1, 2, 3	248579	SHH	SHH	NN
18FE04	R	06	-	-		UPDATED ATTRIBUTES	252025	END	END	AD
19OC04	-	07	-	-		ADDED P/N PE131690	260186	MB	MB	JD

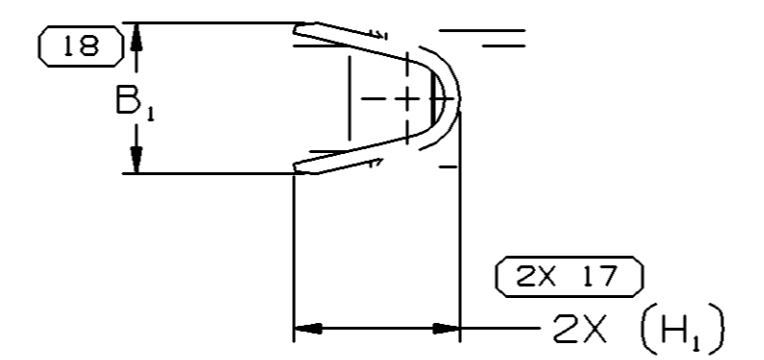
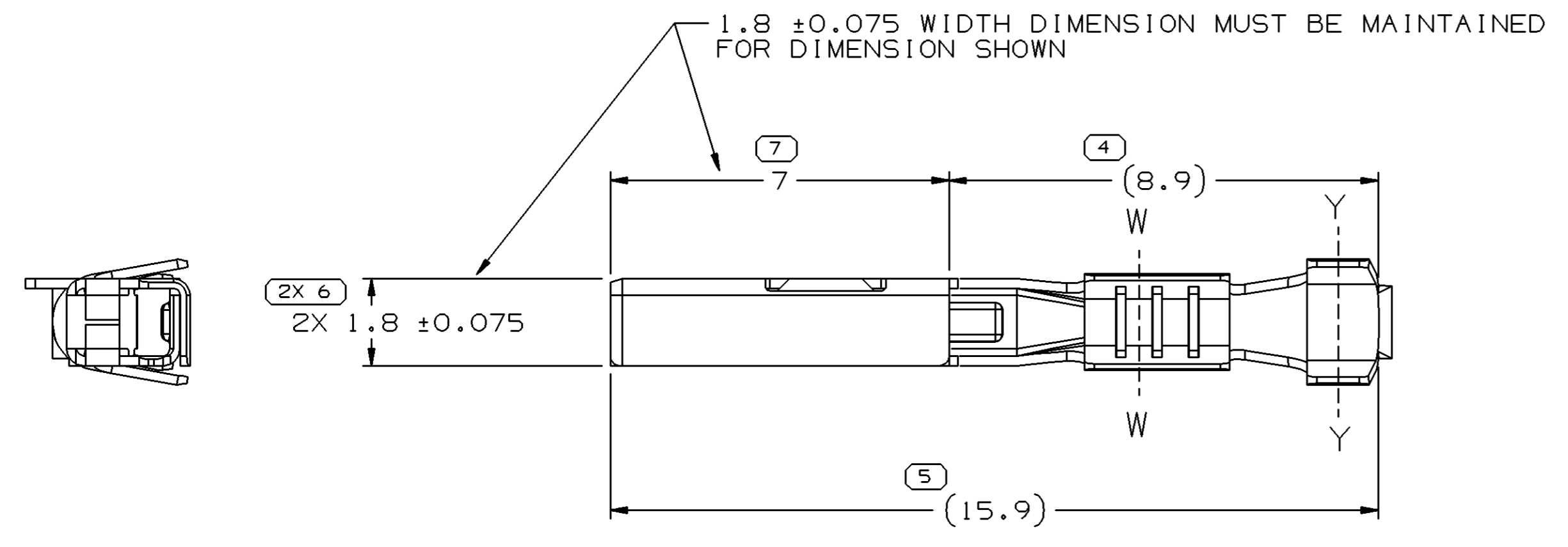

VIEW TO W - W

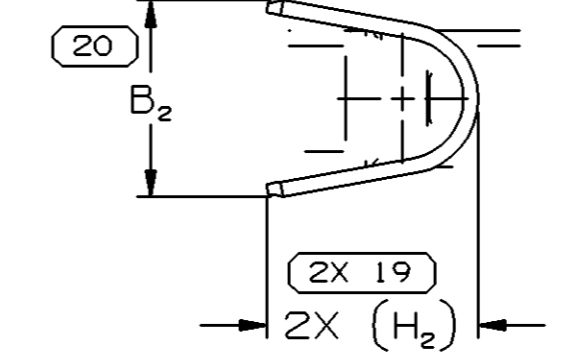

VIEW TO Y - Y

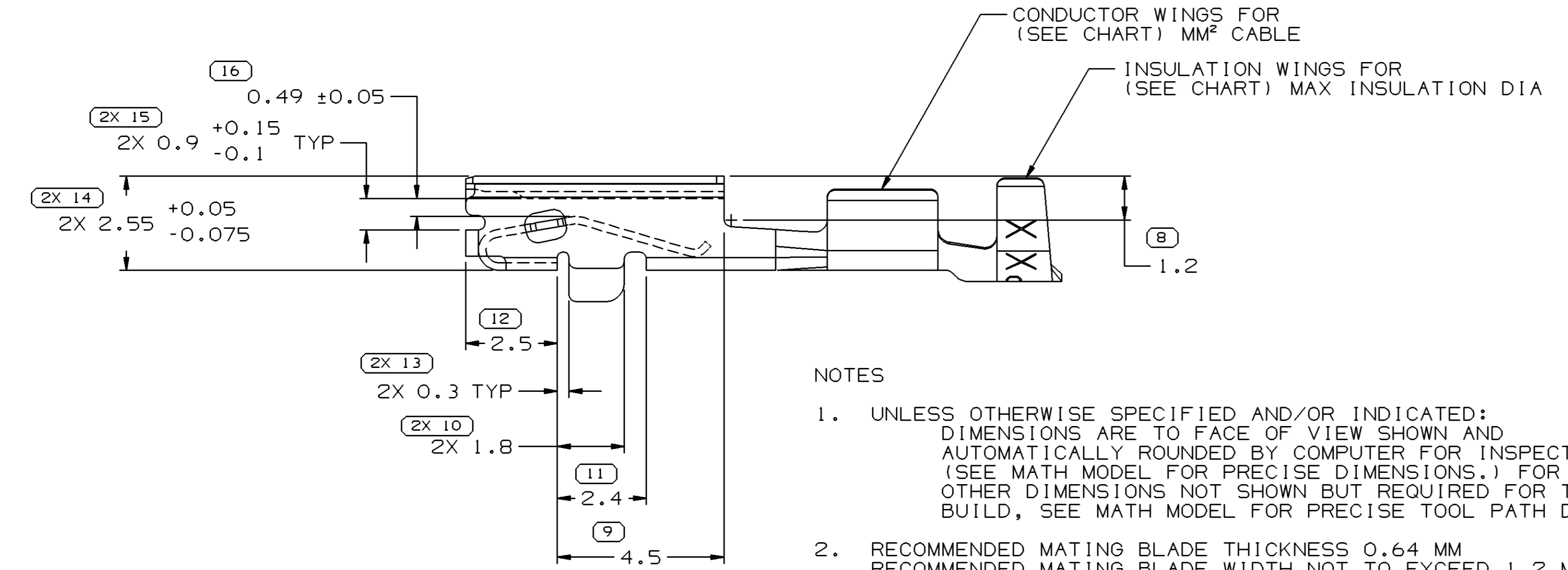

NOTES

- UNLESS OTHERWISE SPECIFIED AND/OR INDICATED: DIMENSIONS ARE TO FACE OF VIEW SHOWN AND AUTOMATICALLY ROUNDED BY COMPUTER FOR INSPECTION. (SEE MATH MODEL FOR PRECISE DIMENSIONS.) FOR ALL OTHER DIMENSIONS NOT SHOWN BUT REQUIRED FOR TOOL BUILD, SEE MATH MODEL FOR PRECISE TOOL PATH DATA.
- RECOMMENDED MATING BLADE THICKNESS 0.64 MM
RECOMMENDED MATING BLADE WIDTH NOT TO EXCEED 1.2 MM
- MAXIMUM CURRENT CAPACITY IS 7 AMPS
- MATING COMPONENTS OR EQUIVALENT:
CONNECTOR 15477027
PIN 15450119 (SEE RECOMMENDED MATING PIN DESIGN VIEW)
- MAX. INSULATION CRIMP WIDTH 1.9 MM
MAX. INSULATION CRIMP HEIGHT 2.8 MM
- REFER TO SAE/USCAR-2 APRIL 2001 (TEMPERATURE CLASS 1, VIBRATION FOR COMPONENTS NOT COUPLED TO ENGINE) FOR PRODUCT PERFORMANCE REQUIREMENTS.
- SEALING CODE 0 - UNSEALED

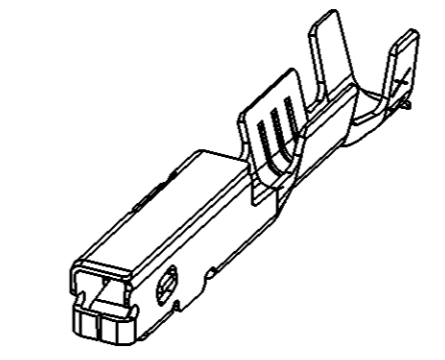
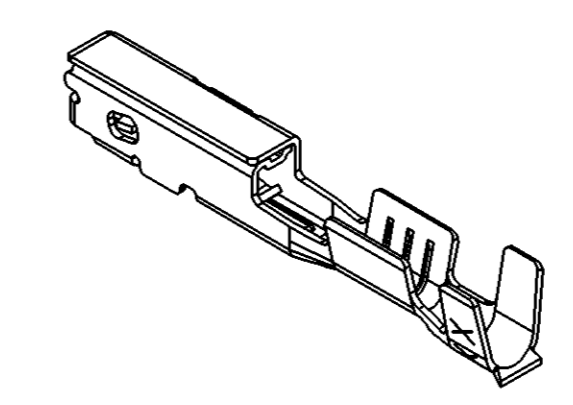

VIEWS SCALE DO NOT REFLECT ACTUAL PARTS SIZE

DWG TYPE		PART DRAWING	
STYLE		D	
VOLUME (CM ³)	DISTR CODE		
	D		
UNLESS OTHERWISE SPECIFIED			
THIS DOCUMENT IS IN ACCORDANCE WITH ASME Y14.5M-1994 AS AMENDED BY THE GM GLOBAL DIMENSIONING AND TOLERANCING ADDENDUM - 1997. ALL GEOMETRIC TOLERANCES AND RELATED DATUMS APPLY RFS. RULE #1 PERFECT FORM AT MMC DOES NOT APPLY WHEN RELATIONSHIP BETWEEN FEATURES IS ESTABLISHED BY ORIENTATION OR LOCATION TOLERANCES. SEPARATE POSITION CALLOUTS MAY BE GAGED SEPARATELY, REGARDLESS OF DATUM REFERENCE. ALL DIMENSIONS ARE IN MILLIMETERS			
REFERENCE			
THIRD ANGLE PROJECTION		DO NOT SCALE	
USE MATH DATA		UNIGRAPHICS	

DELPHI
DELPHI PACKARD ELECTRIC SYSTEMS
WARREN, OH

DR	DATE
APVD1 G. LOPEZ G.	30AU02
APVD2 J. VILLAMIL	02SE02
APVD3 KASEGNE ALEX	03SE02
APVD4	
APVD5	

SUBSTANCES OF CONCERN AND RECYCLED CONTENT PER DELPHI 10949001

MATERIAL SEE CHART

DRAWING NAME TAXI TERM F MICRO HVT

DRAWING NUMBER 15443837

SIZE A1	SCALE 10:1	FRAME NO 1 OF 1	SHEET NO 1 OF 2	STG -	REV 07	N/P -
---------	------------	-----------------	-----------------	-------	--------	-------

PE131690	U	01	-	-	0.2 X 27.5	M3659B76 C42500 EX HD	0.13 - 0.22	25	1.01 - 0.88	1.4	1.8	1.6	1.7
15445905	R	05	-	-	0.2 X 27.5	M3659B76 C42500 EX HD	0.75	18	1.9 - 1.7	2.5	2.6	2.7	2.9
15445904	R	05	-	-	0.2 X 27.5	M3659B76 C42500 EX HD	0.35 - 0.5	21	1.83 - 1.47	2	2.6	2.2	2.9
PART NO	STG	REV	N/P	STATUS	MAT'L SIZE	MAT'L SPEC	SIZE (MM ²)	ID	DIA	B ₁ ±0.2	B ₂ ±0.3	(H ₁)	(H)

6 PROCESS SENSITIVE DIMENSION	
DIMENSIONS ENCLOSED IN () INDICATE REFERENCE DIMENSIONS AND NO TOLERANCE LIMITS ARE ESTABLISHED	
DIMENSIONAL RANGE (MM)	CHART D
FROM 0 TO 12	> 12
TOLERANCE UNLESS OTHERWISE SPECIFIED ±0.1	±0.2
ANGULAR TOLERANCE ±2°	

Mouser Electronics

Authorized Distributor

Click to View Pricing, Inventory, Delivery & Lifecycle Information:

[Aptiv:](#)

[15445905](#) [15445904](#)