

MOD		LOC	DIST	REVISIONS			
P	F	ZONE	LTR	DESCRIPTION	DATE	APPD	
4		BD	39	AE	REDRAWN, ADDED 1--4 PER NPR 3506	5-9-91	RW
				AF	ADDED 1--5 PER NPR 4680	04/02/93	RSK
				AF1	REVISED PER ECO-09-020935	09SEP09	AEG

WHEN ORDERING CONTACT ASSEMBLY ON TAPE, ORDER BY THE TAPE NUMBER PLUS THE PACKAGING CODE AS FOLLOWS:

1. FOR USE WITH AMP TAPETRONIC, PNEUMATIC TOOL—
  - A. 1000 PARTS TO A BOX ADD PACKAGING CODE: 1MBOX
2. FOR USE WITH 4/8 INDENT STRIPPER CRIMPER—
  - A. 1000 PARTS TO A REEL ADD PACKAGING CODE: 1MREEL
  - B. 5000 PARTS TO A REEL ADD PACKAGING CODE: 5MREEL

3 OBSOLETE PARTS: OBSOLETE CIS STREAMLINING PER D.RENAUD/D.SINISI

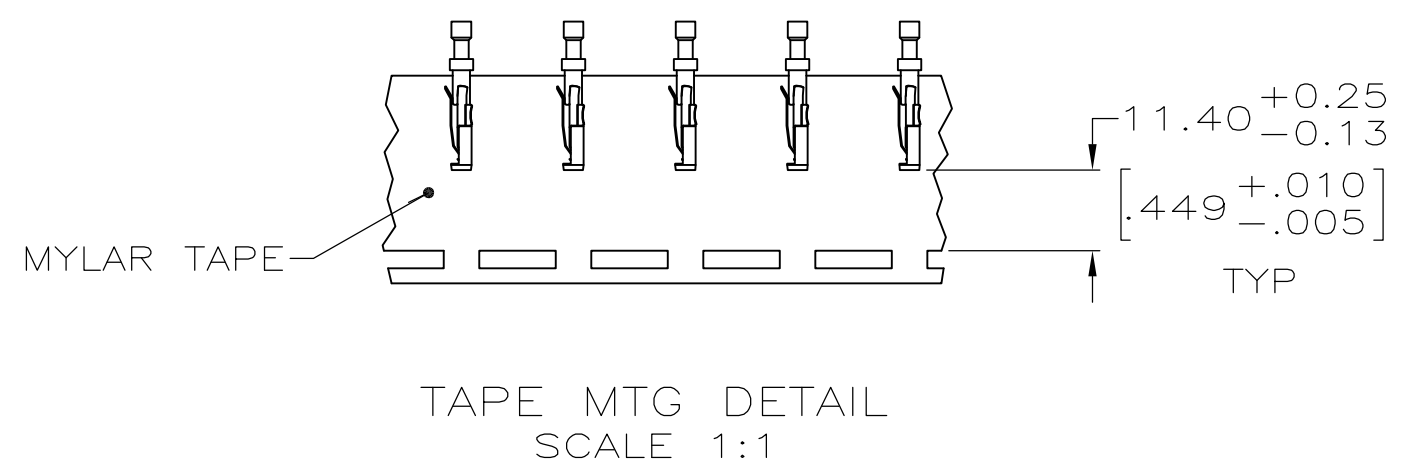
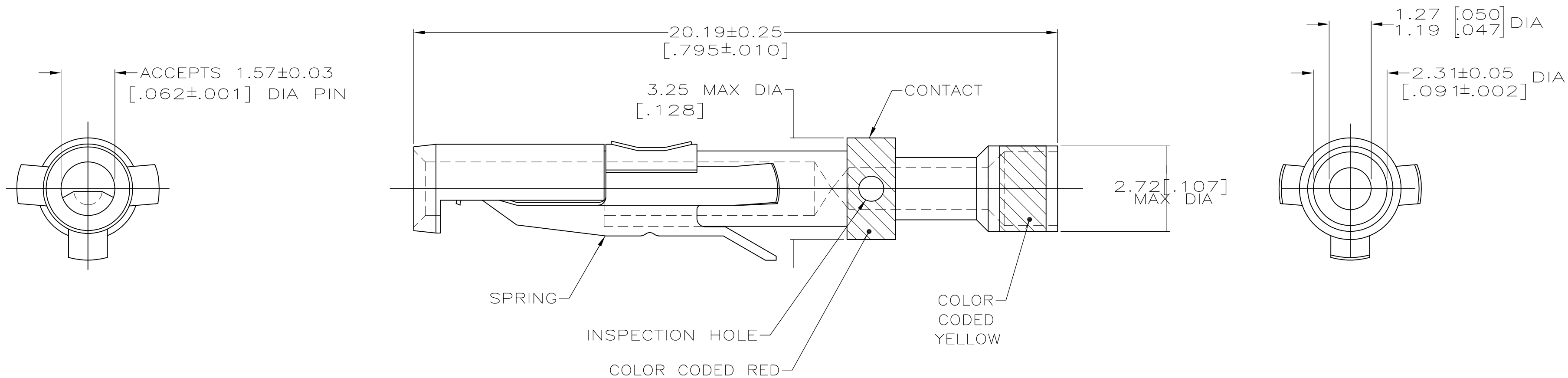

3 OBSOLETE	SMALL PACK KIT	1-201328-5 1-201328-4
	TAPE MTG SEE DETAIL	201328-9
	BULK	201328-1
	PACKAGING	PART NO

DO NOT SCALE PRINT. UNLESS SPECIFIED DIMENSIONS IN mm [INCHES] TOLERANCES ON :	DR 5-9-91 W.G.LENKER	AMP Incorporated Harrisburg, PA 17105-3608		
2 PLC DEC ± -	CHK 5-14-91 R.STONE			
3 PLC DEC ± -	APPD 5-14-91 R.WALTER	NAME		
ANGLES ± -	APPD -	SOCKET CONTACT ASSEMBLY, TYPE II		
MATERIAL	PRODUCT SPEC -			
CONTACT: BRASS	APPLICATION SPEC -	SIZE	CAGE CODE	DRAWING NO
SPRING: STAINLESS STEEL	WEIGHT -	00779	10:1	201328
FINISH		SCALE		SHEET
CONTACT: $0.76 \mu\text{m}$ [ $.000030$ ]				1 OF 1
MIN GOLD OVER $1.27 \mu\text{m}$ [ $.000050$ ] MIN NICKEL				

# Mouser Electronics

Authorized Distributor

Click to View Pricing, Inventory, Delivery & Lifecycle Information:

[TE Connectivity:](#)

[201328-9](#)