

Apr.1.2019 Copyright 2019 HIROSE ELECTRIC CO., LTD. All Rights Reserved.  
In case of consideration for using Automotive equipment / device which demand high reliability, kindly contact our sales window correspondents.

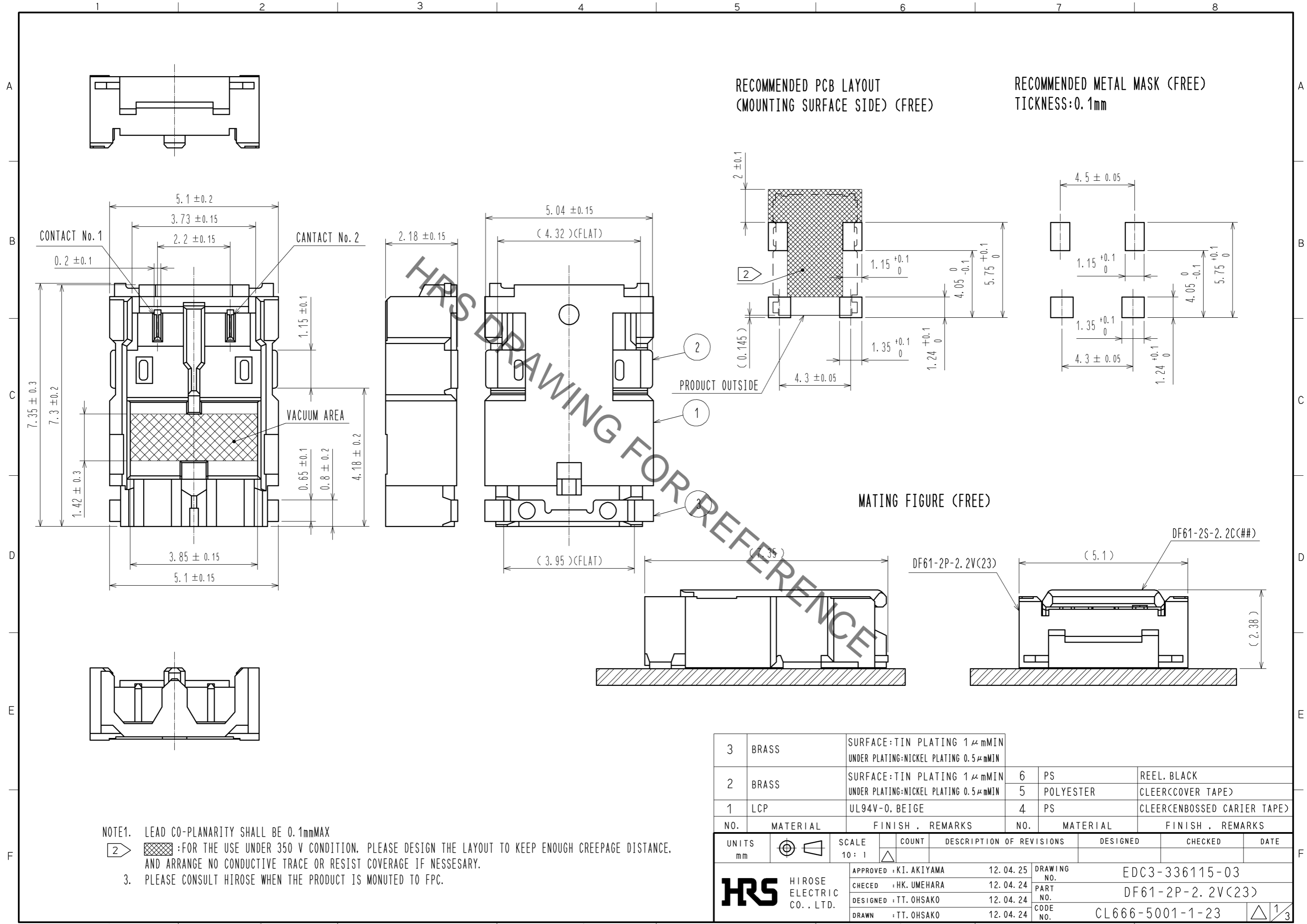

NOTE1. LEAD CO-PLANARITY SHALL BE 0.1mmMAX

2. :FOR THE USE UNDER 350 V CONDITION. PLEASE DESIGN THE LAYOUT TO KEEP ENOUGH CREEPAGE DISTANCE. AND ARRANGE NO CONDUCTIVE TRACE OR RESIST COVERAGE IF NECESSARY.

3. PLEASE CONSULT HIROSE WHEN THE PRODUCT IS MONUTED TO FPC.

3	BRASS	SURFACE:TIN PLATING 1 μmMIN UNDER PLATING:NICKEL PLATING 0.5 μmMIN			
2	BRASS	SURFACE:TIN PLATING 1 μmMIN UNDER PLATING:NICKEL PLATING 0.5 μmMIN	6	PS	REEL. BLACK
1	LCP	UL94V-0. BEIGE	5	POLYESTER	CLEER(COVER TAPE)
			4	PS	CLEER(CENBOSSED CARRIER TAPE)
NO.	MATERIAL	FINISH . REMARKS	NO.	MATERIAL	FINISH . REMARKS
UNITS mm		SCALE 10:1	COUNT		DESCRIPTION OF REVISIONS
					DESIGNED
					CHECKED
					DATE
APPROVED : KI. AKIYAMA			12.04.25		
CHECED : HK. UMEHARA			12.04.24		
DESIGNED : TT. OHSAKO			12.04.24		
DRAWN : TT. OHSAKO			12.04.24		
DRAWING NO.			EDC3-336115-03		
PART NO.			DF61-2P-2.2V(23)		
CODE NO.			CL666-5001-1-23		

Apr.1.2019 Copyright 2019 HIROSE ELECTRIC CO., LTD. All Rights Reserved.  
 In case of consideration for using Automotive equipment / device which demand high reliability, kindly contact our sales window correspondents.

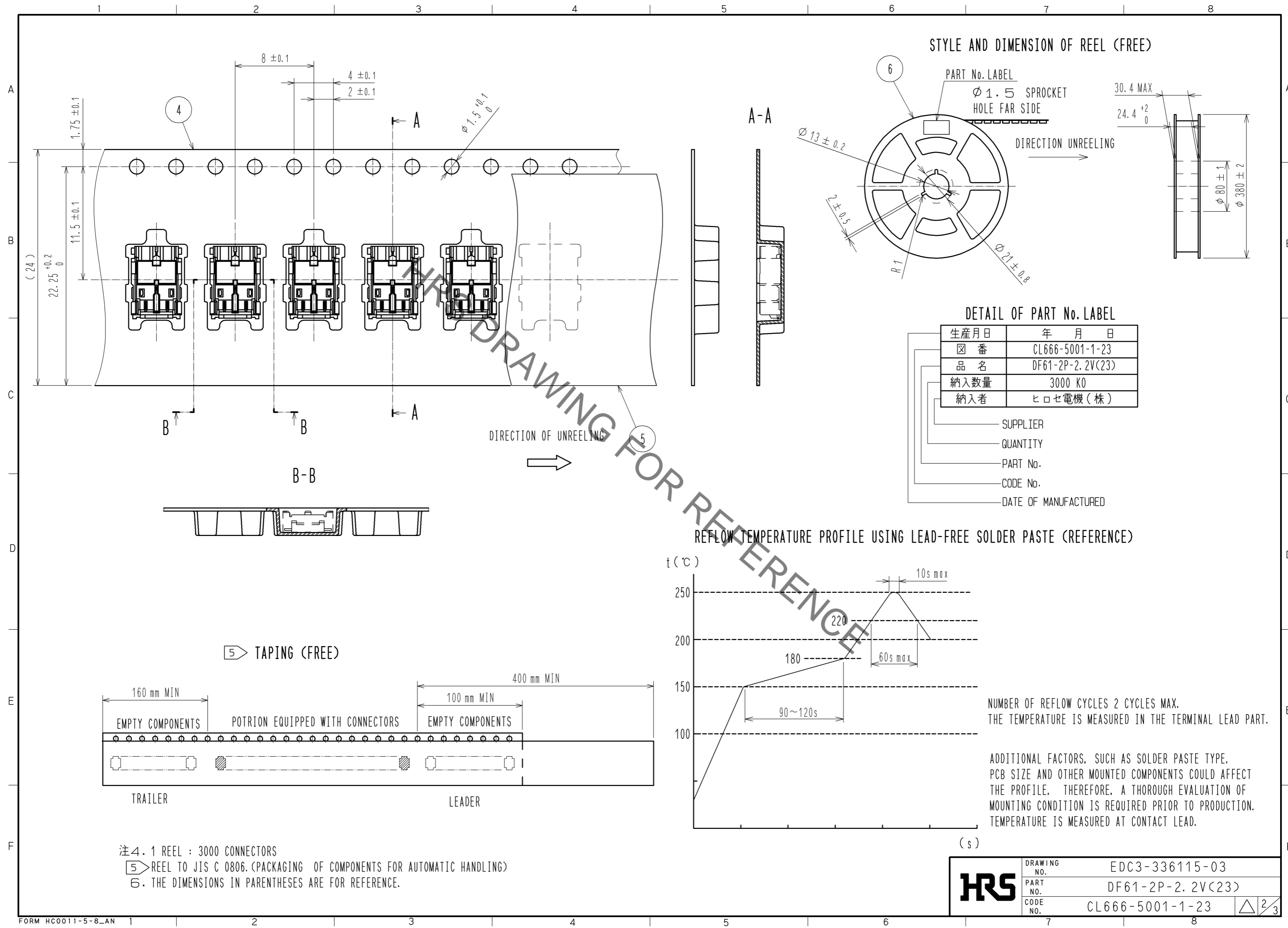

STYLE AND DIMENSION OF REEL (FREE)

PART No. LABEL

Ø 1.5 SPROCKET HOLE FAR SIDE

DIRECTION UNREELING

DETAIL OF PART No. LABEL

生産月日	年 月 日
☒ 番	CL666-5001-1-23
品名	DF61-2P-2.2V(23)
納入数量	3000 K0
納入者	ヒロセ電機(株)

- SUPPLIER
- QUANTITY
- PART No.
- CODE No.
- DATE OF MANUFACTURED

REFLOW TEMPERATURE PROFILE USING LEAD-FREE SOLDER PASTE (REFERENCE)

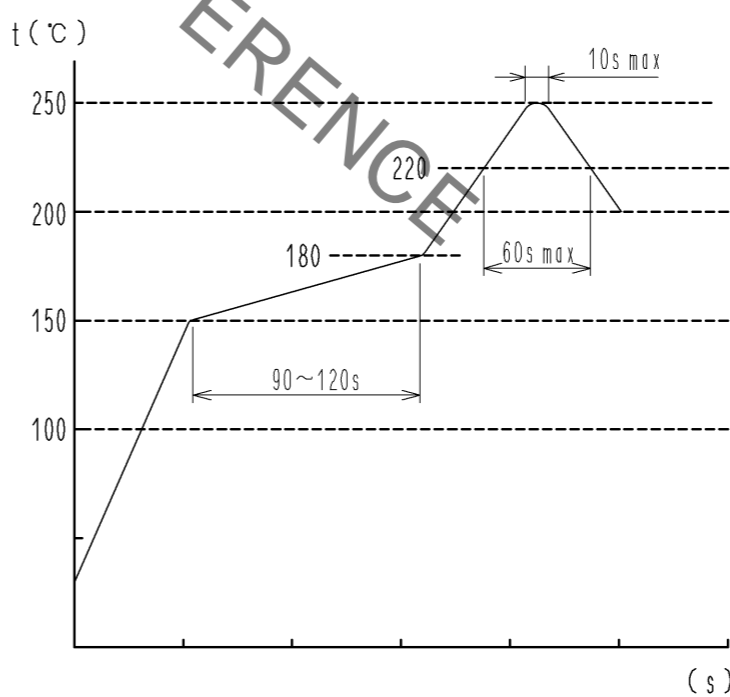

NUMBER OF REFLOW CYCLES 2 CYCLES MAX.  
 THE TEMPERATURE IS MEASURED IN THE TERMINAL LEAD PART.

ADDITIONAL FACTORS, SUCH AS SOLDER PASTE TYPE, PCB SIZE AND OTHER MOUNTED COMPONENTS COULD AFFECT THE PROFILE. THEREFORE, A THOROUGH EVALUATION OF MOUNTING CONDITION IS REQUIRED PRIOR TO PRODUCTION. TEMPERATURE IS MEASURED AT CONTACT LEAD.

注4. 1 REEL : 3000 CONNECTORS  
 ⑤ REEL TO JIS C 0806. (PACKAGING OF COMPONENTS FOR AUTOMATIC HANDLING)  
 ⑥ THE DIMENSIONS IN PARENTHESES ARE FOR REFERENCE.

<b>HRS</b>	DRAWING NO.	EDC3-336115-03
	PART NO.	DF61-2P-2.2V(23)
	CODE NO.	CL666-5001-1-23
		△ 2/3

# DF61 Series Mating / Unmating Operation Instruction

## Mating

① By positioning the convexity of the socket sides to the header concavity, align the centers of the socket and the header in pitch direction.

② Slightly press the socket down at cable side to tilted angle.

③ Press down at the lever side with stabilizing the cable side to insert. Mating completes.

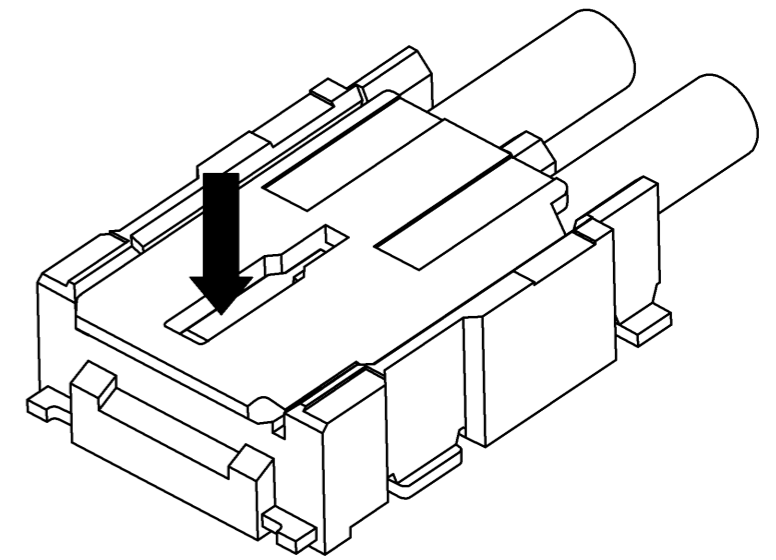
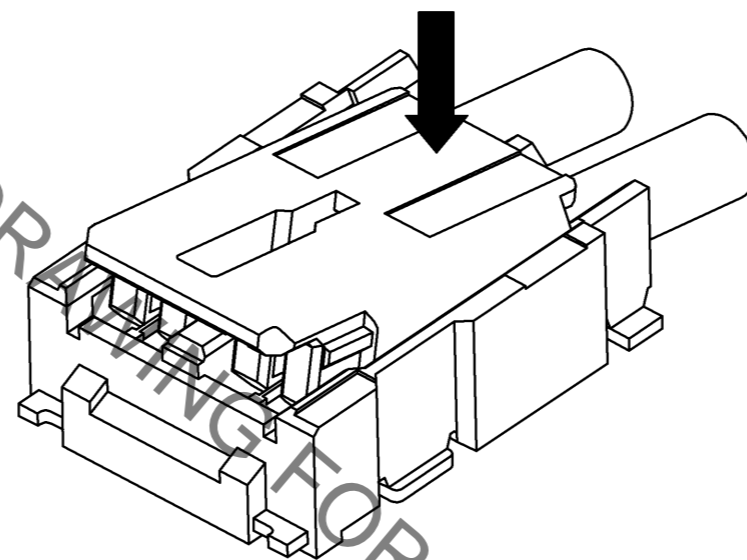
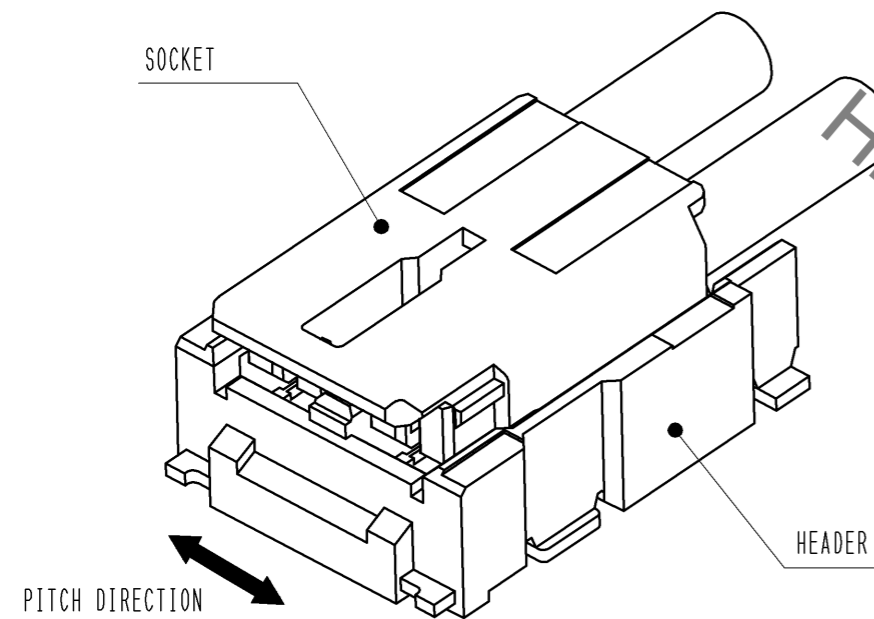

## Unmating

① Hook the lever with finger nail.

② Lift up to the upper direction and friction lock is released.

③ Lift up to the upper direction and positive lock is released. Removal completes.

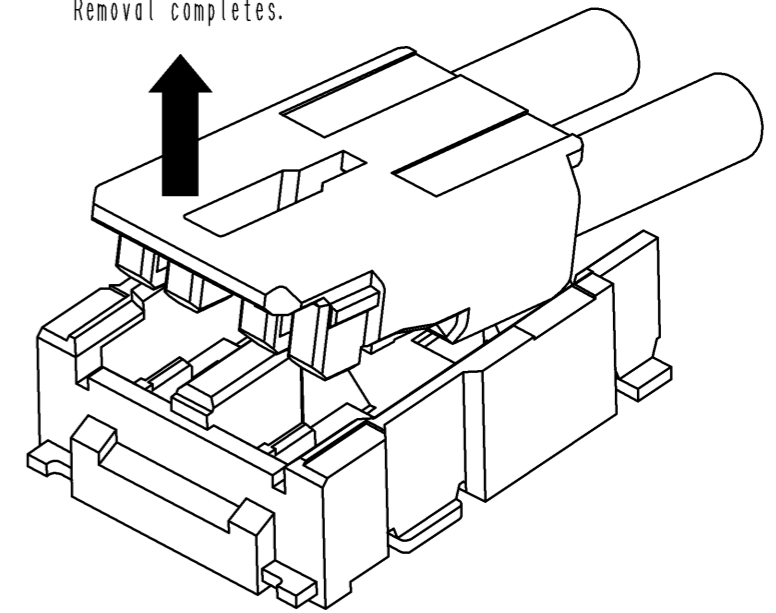
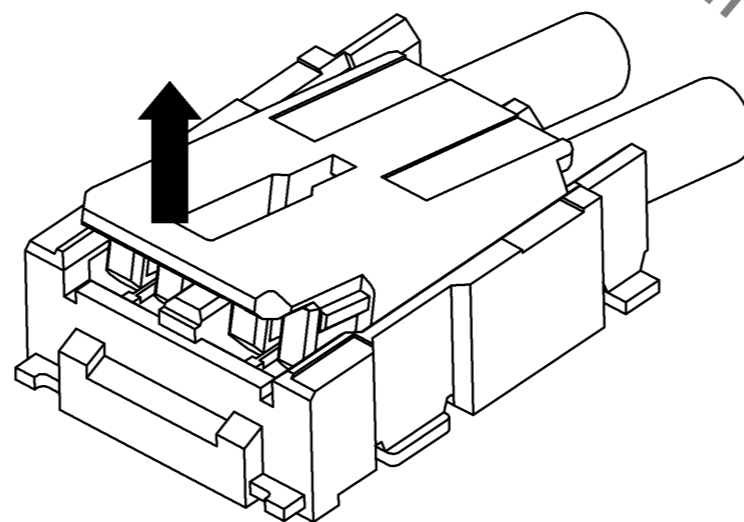
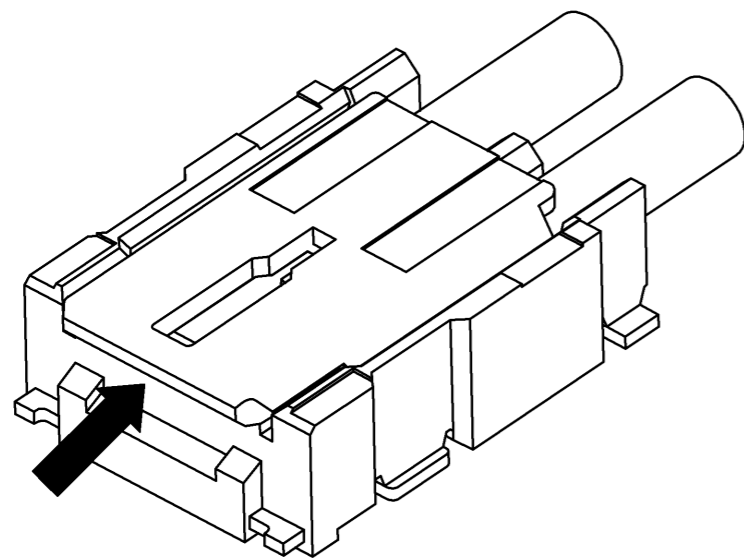

**HRS**

図番: EDC3-336115-03  
 製品名: DF61-2P-2.2V(23)  
 製品コード: CL666-5001-1-23

3/3