

REVISIONS				
P.	LTN	DESCRIPTION	DATE	APPV
A18	ECR-16-006173		04MAY2016	MB JK
A19	ECR-16-009404		22SEP2016	MB JK
A20	ECR-17-005648		21OCT2017	MB PST
A21	ECR-18-014391		24SEP2018	SCK RP

CONTACTS FOR FLR-CABLE
 Kontakte fuer FLR-Leitung

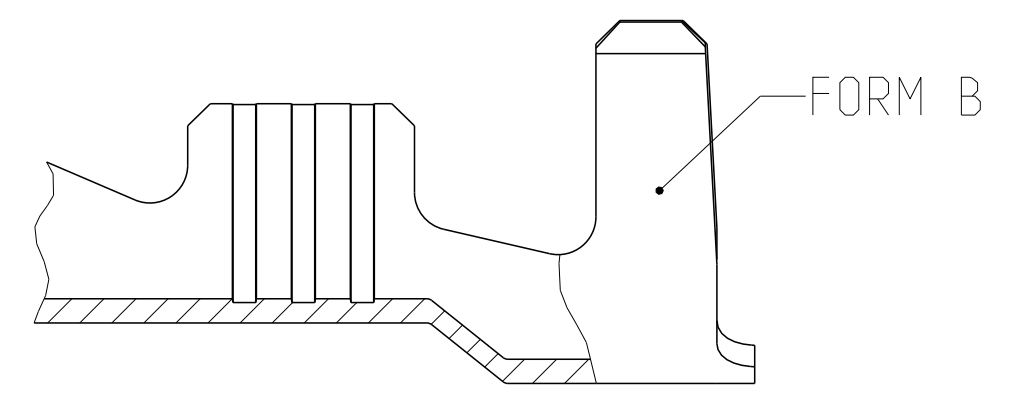

DESIGN 963898 / 963900 / 963904
 Ausfuehrung 963898 / 963900 / 963904

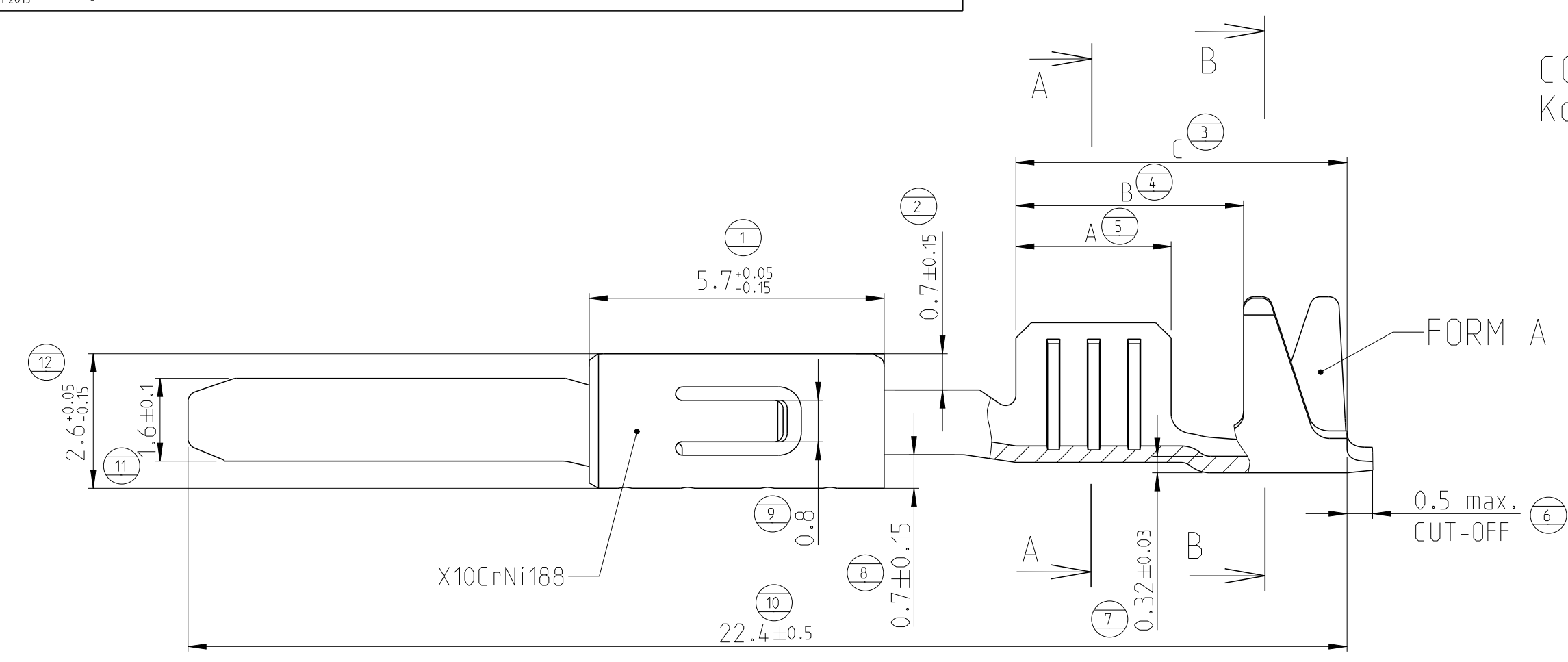
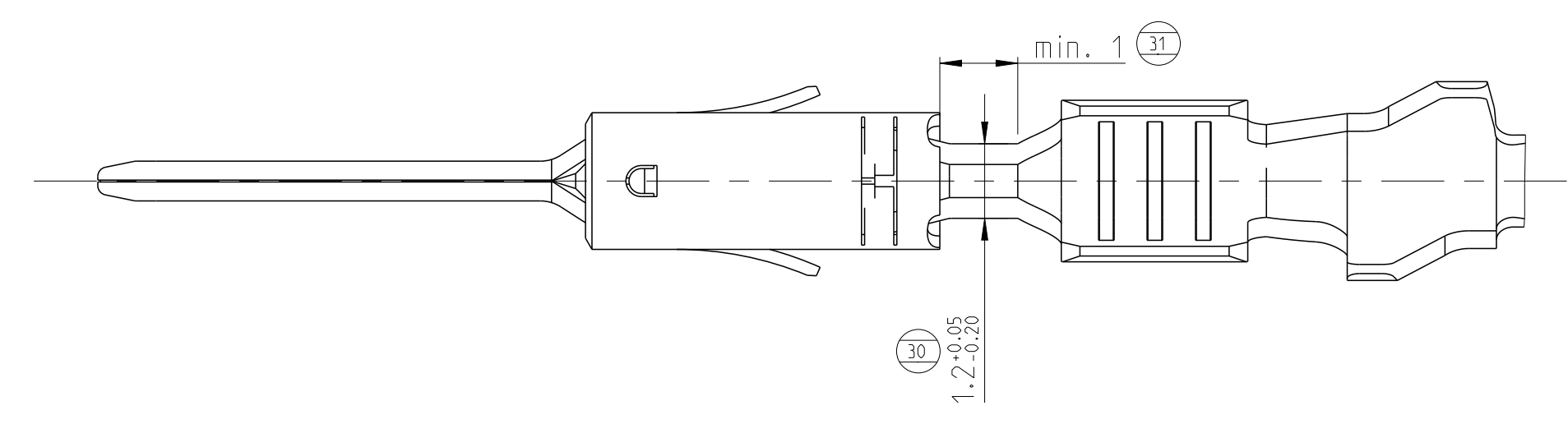
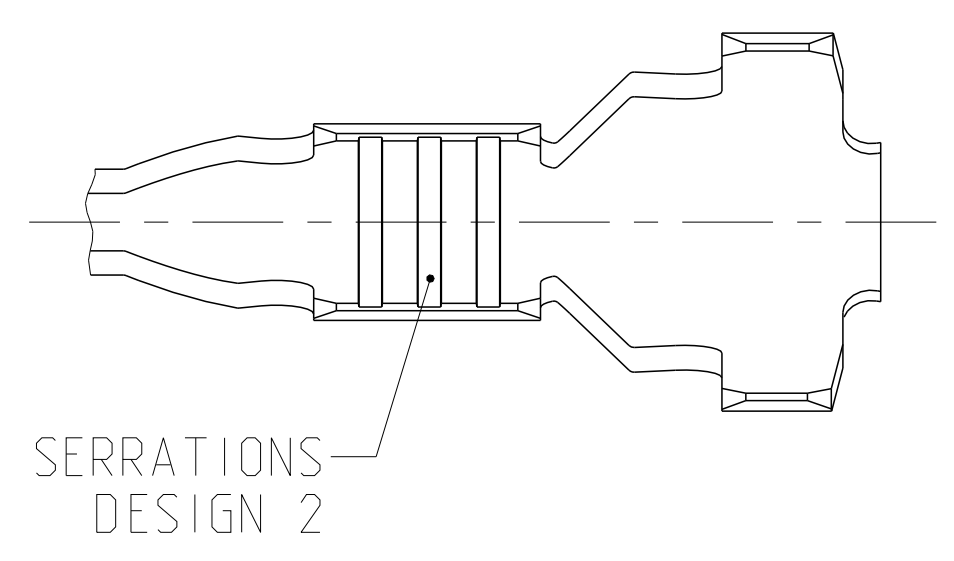
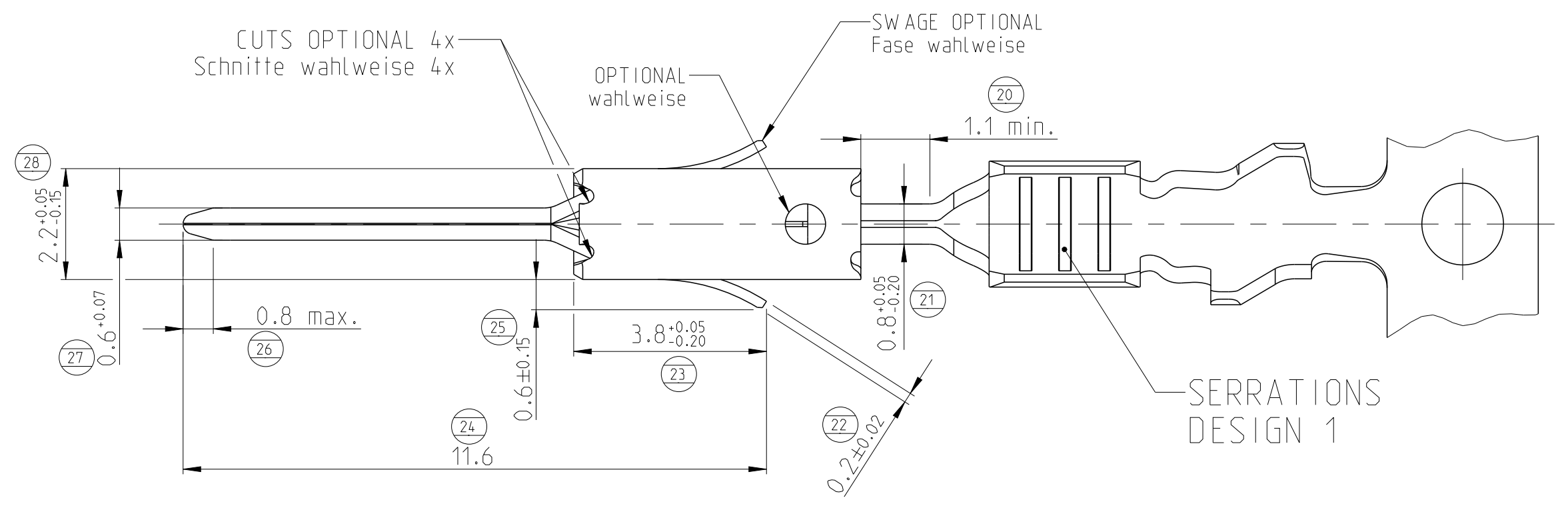
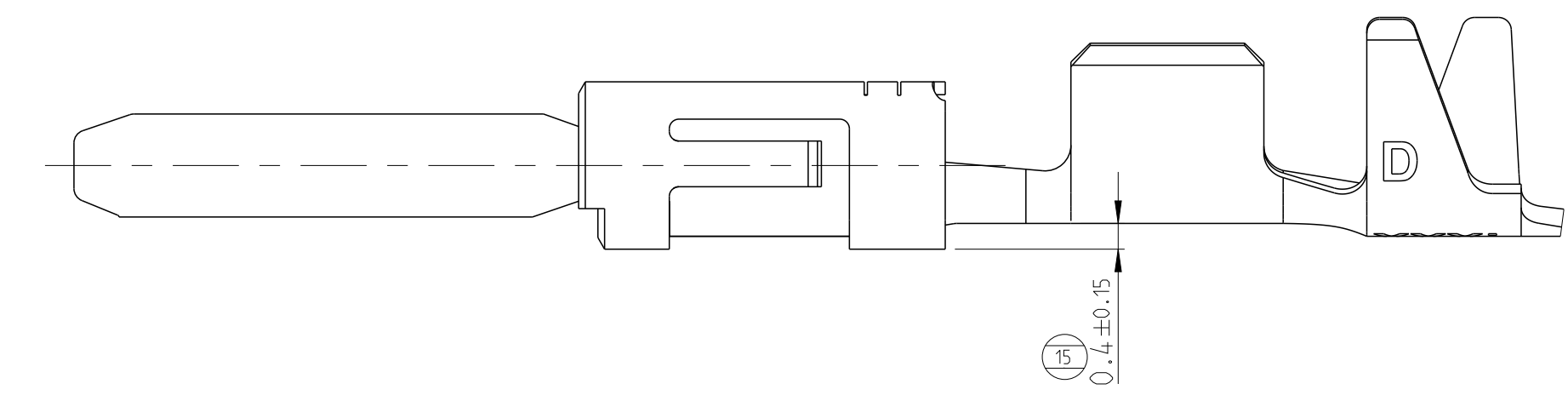

CONTACTS FOR SINGLE WIRE SEALING SYSTEM:
 FLR- AND FLK-CABLE
 Kontakte fuer Einzeldichtung-System:
 FLR- und FLK-Leitung

DIMENSIONS SEE FIGURE CONTACTS FOR FLR-CABLE
 Masse siehe Darstellung der Kontakte fuer FLR-Leitung

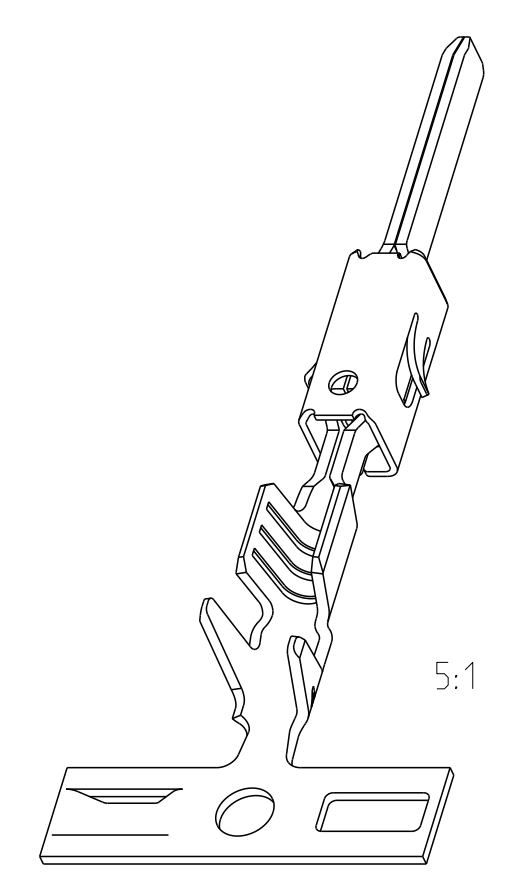
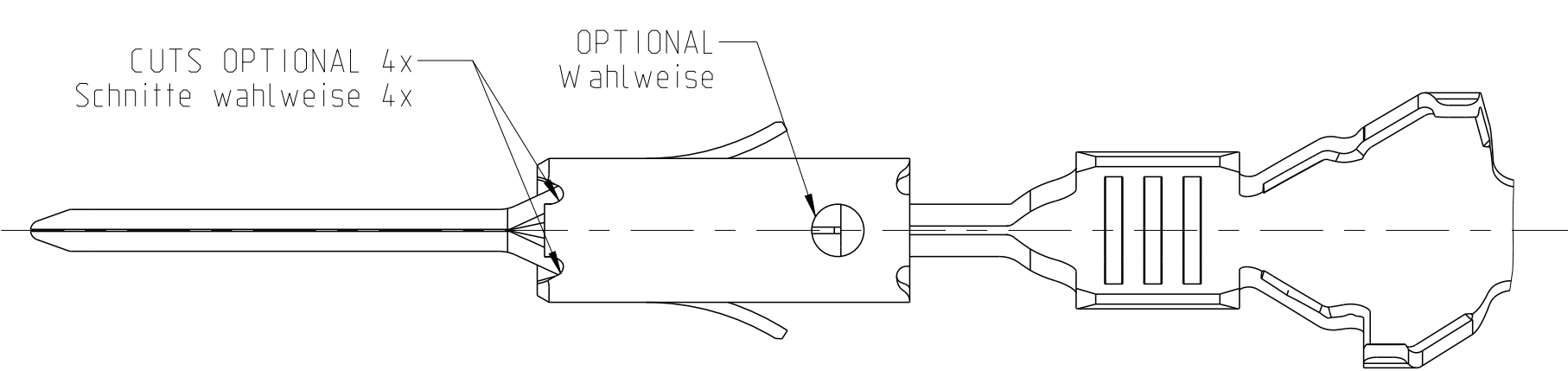
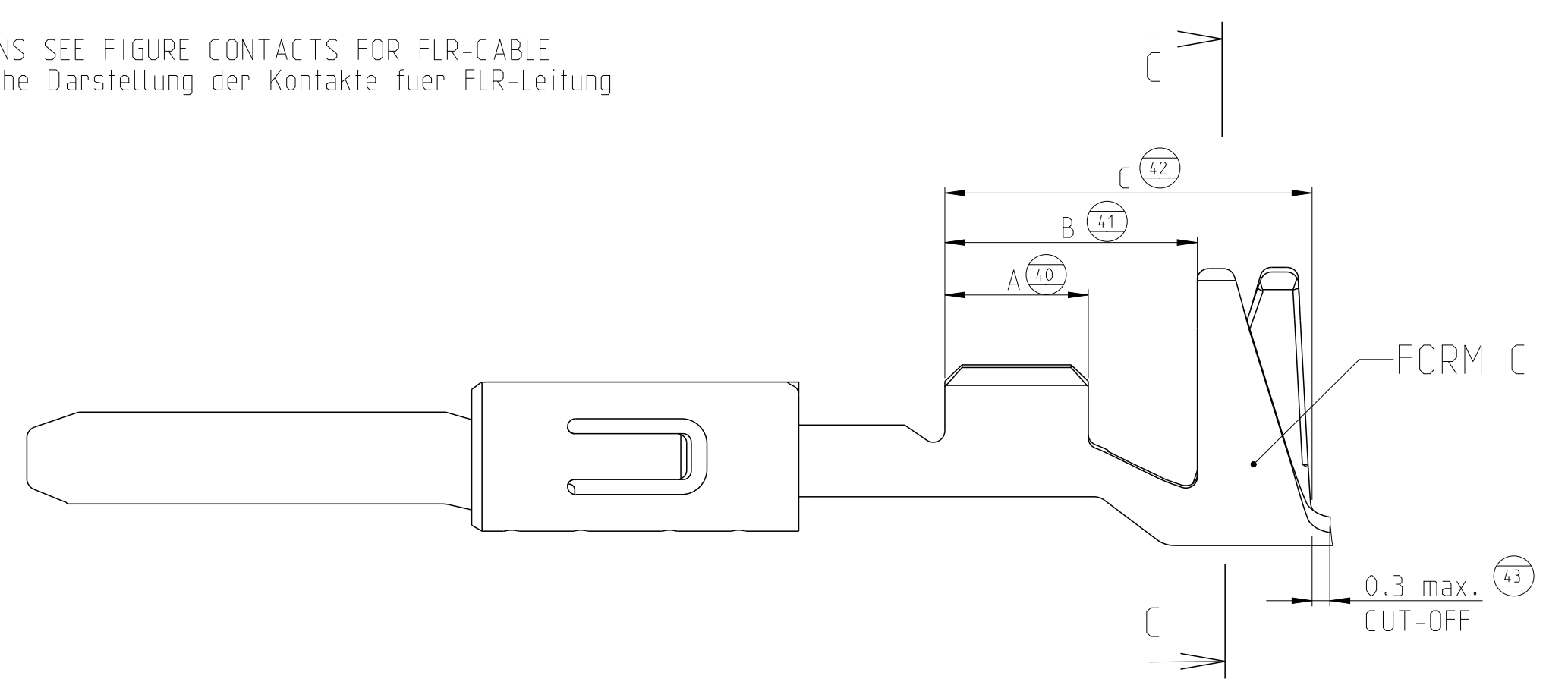

DESIGN 963902
 Ausfuehrung 963902

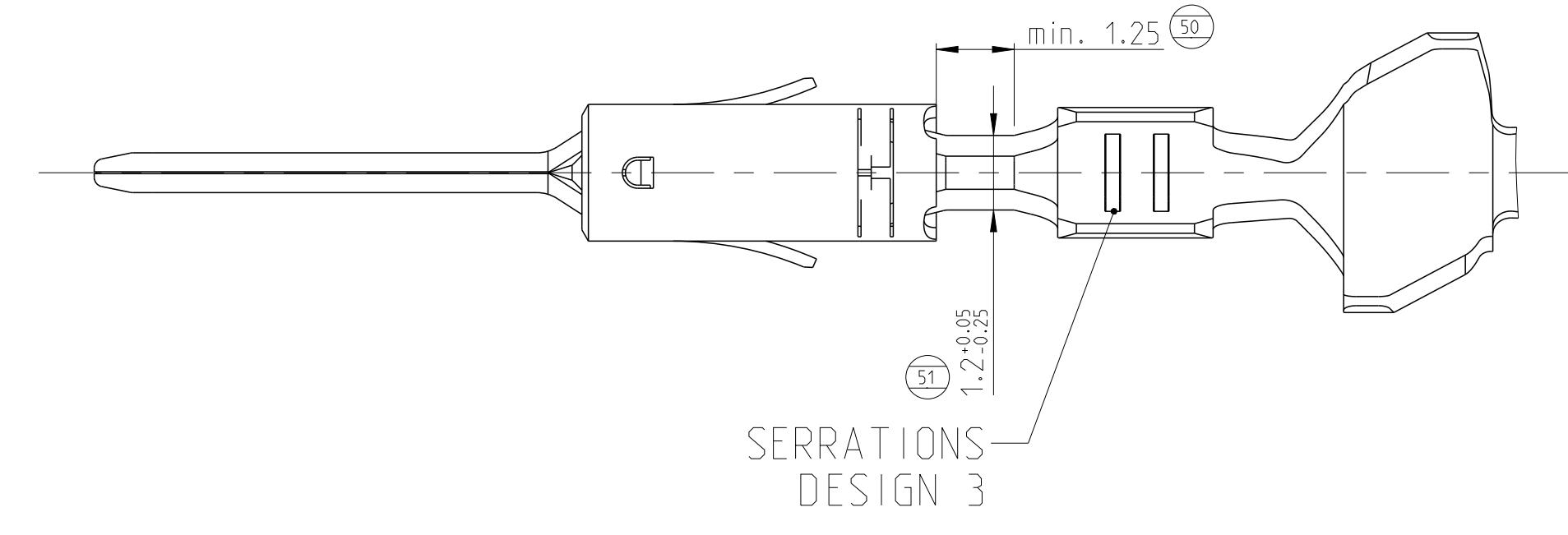
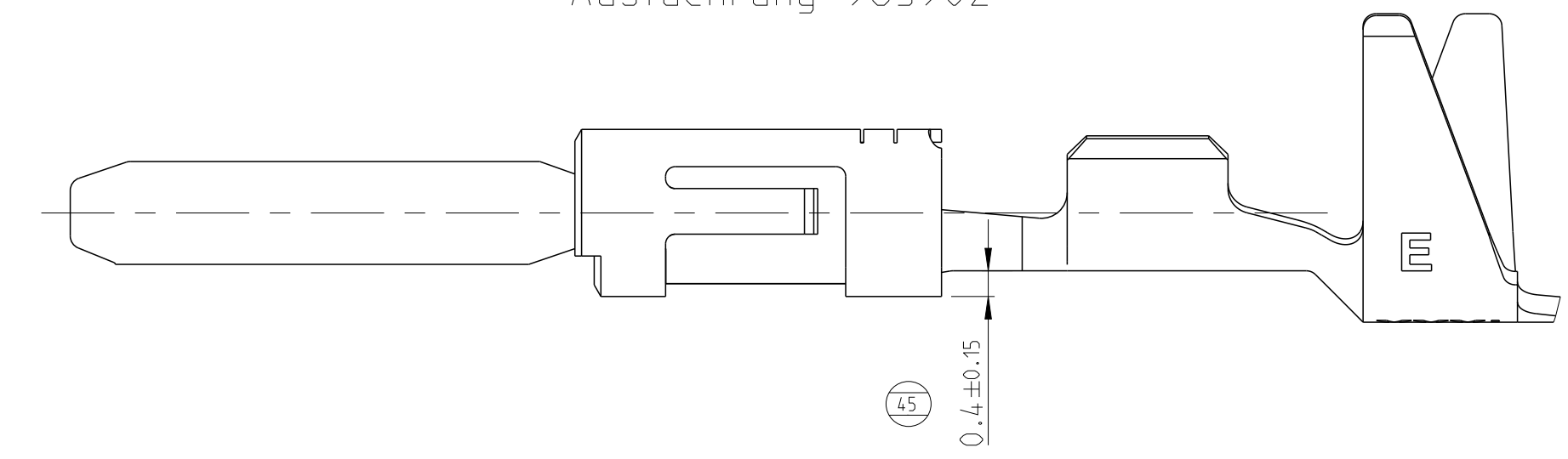

SERRATIONS DESIGN 3

THIS DRAWING IS A CONTROLLED DOCUMENT.		OWN: T. Bensch 11JUN1997	TE Connectivity
DIMENSIONS: mm		CHK: U. Muenk 11JUN1997	
TOLERANCES UNLESS OTHERWISE SPECIFIED: ±0.2		APPV: M. Bleicher 02MAR2011	NAME: PRODUCT GROUP DRAWING
MATERIAL: SEE TABLE sheet 2		FINISH: SEE TABLE sheet 2	TAB 1.6 x 0.6
WEIGHT: -		SIZE: 114-18082	Flachstecker 1.6 x 0.6
CUSTOMER DRAWING		SCALE: 10:1	SHEET 1 OF 2
		REVISION: A21	

REVISIONS				
P.	LTN	DESCRIPTION	DATE	APPV
-	SEE SHEET 1			

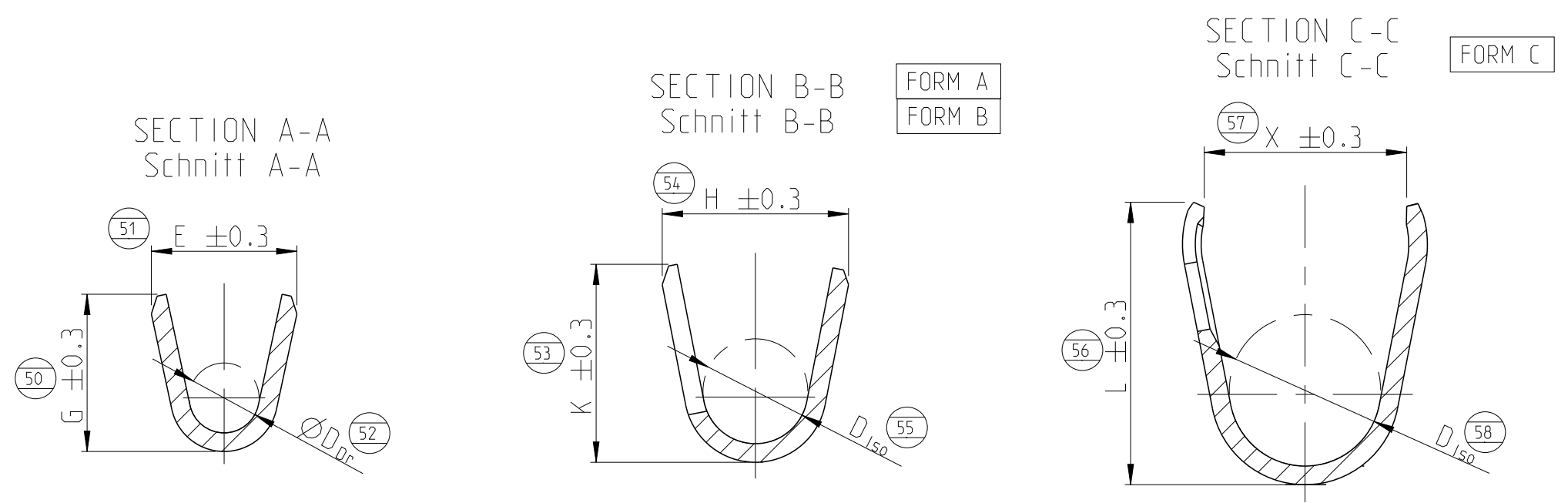

SINGLE WIRE SEAL / Einzelichtungssystem	TE ORDER-NO.	REV	DESIGN SERRATIONS / Ausführung Serrations	MATERIAL / Werkstoff	SURFACE / Oberfläche	DGB / mm ²	INSULATION / Isolations	SEE / siehe SECTION A-A Schnitt A-A	SEE / siehe SECTION B-B / C-C Schnitt B-B / C-C	HAND TOOL / Handzange	INSERT / Matrize	A	B	C	X	TE ORDER-NO.	CRIMP DATA AND CRIMP TOOL / Crimpdaten und Crimpwerkzeuge
								E = 2.8 G = 3.0 D _{Dr} = 1.4	L = 4.9 D _{ISO} = 2.9								
UNSEALED / ungedichtet	1703278-5	A	1	CuSn4	5	1.5	1.95 - 2.4	E = 2.8 G = 3.0 D _{Dr} = 1.4	L = 4.9 D _{ISO} = 2.9	169400-0 539635-1	539960-1						
	1703278-2	A	1	CuFe2	4	0.5 - 1.0	1.4 - 2.1	E = 2.5 G = 2.7 D _{Dr} = 1.2	L = 4.8 D _{ISO} = 2.7								
	2-964269-2	A	1	CuFe2	5												
	964269-5	A	1	CuSn4	5	0.5 - 1.0	1.4 - 2.1	E = 2.6 G = 2.8 D _{Dr} = 1.2	H = 4.5 K = 4.8 D _{ISO} = 2.7								
	964269-3	E	1	CuSn4	1												
	964269-2	D	1	CuFe2	4	0.35	1.15 - 1.6	E = 2.4 G = 2.3 D _{Dr} = 1.0	L = 4.8 D _{ISO} = 2.6								
	963904-3	G	1	CuSn4	1												
	963904-2	F	1	CuFe2	4	0.2 - 0.5	1.15 - 1.6	E = 2.1 G = 2.1 D _{Dr} = 0.8	H = 4.5 K = 4.8 D _{ISO} = 2.7								
	963904-1	F	1	CuSn4	4												
	2141884-5	A	2	CuSn4	5	0.2 - 0.5	1.15 - 1.6	E = 2.1 G = 2.1 D _{Dr} = 0.8	H = 4.5 K = 4.8 D _{ISO} = 2.7								
	2141884-3	B	2	CuSn4	1												
	2-2141884-2	A	2	CuFe2	5	0.2 - 0.5	1.15 - 1.6	E = 2.1 G = 2.1 D _{Dr} = 0.8	H = 4.5 K = 4.8 D _{ISO} = 2.7								
	2141884-2	A	2	CuFe2	4												
	969028-5	A	3	CuSn4	5	0.2 - 0.5	1.15 - 1.6	E = 2.1 G = 2.1 D _{Dr} = 0.8	H = 4.5 K = 4.8 D _{ISO} = 2.7								
	969028-3	E	3	CuSn4	1												
	969028-2	D	3	CuFe2	4	0.2 - 0.5	1.15 - 1.6	E = 2.1 G = 2.1 D _{Dr} = 0.8	H = 4.5 K = 4.8 D _{ISO} = 2.7								
	963902-3	E	3	CuSn4	1												
	963902-2	D	3	CuFe2	4	0.2 - 0.5	1.15 - 1.6	E = 2.1 G = 2.1 D _{Dr} = 0.8	H = 4.5 K = 4.8 D _{ISO} = 2.7								
963902-1	D	3	CuSn4	4													
1241846-5	A	1	CuSn4	5	1.5	2.2 - 2.4	E = 2.8 G = 3.0 D _{Dr} = 1.4	H = 3.5 K = 3.9 D _{ISO} = 1.9									
1241846-3	B	1	CuSn4	1													
1241846-2	A	1	CuFe2	4	0.5 - 1.0	1.4 - 2.1	E = 2.5 G = 2.8 D _{Dr} = 1.2	H = 3.7 K = 3.9 D _{ISO} = 1.8									
1241846-1	A	1	CuSn4	4													
969079-3	C	1	CuSn4	1	0.5 - 1.0	1.4 - 2.1	E = 2.5 G = 2.8 D _{Dr} = 1.2	H = 3.7 K = 3.9 D _{ISO} = 1.8									
969079-2	B	1	CuFe2	4													
964267-4	A	1	CuSn4	5	0.5 - 1.0	1.4 - 2.1	E = 2.5 G = 2.7 D _{Dr} = 1.2	H = 3.2 K = 3.4 D _{ISO} = 1.8									
964267-3	D	1	CuSn4	1													
964267-2	C	1	CuFe2	4	0.5 - 1.0	1.4 - 2.1	E = 2.6 G = 2.8 D _{Dr} = 1.2	H = 3.2 K = 3.4 D _{ISO} = 1.8									
964267-1	C	1	CuSn4	4													
963900-4	E	1	CuSn4	1	0.2 - 0.5	1.15 - 1.6	E = 2.1 G = 2.1 D _{Dr} = 0.8	H = 2.9 K = 2.9 D _{ISO} = 1.4									
963900-3	E	1	CuSn4	1													
963900-2	D	1	CuFe2	4	0.2 - 0.5	1.15 - 1.6	E = 2.1 G = 2.1 D _{Dr} = 0.8	H = 2.9 K = 2.9 D _{ISO} = 1.4									
963900-1	D	1	CuSn4	4													
963898-3	E	3	CuSn4	1	0.2 - 0.35	1.15 - 1.6	E = 2.4 G = 2.3 D _{Dr} = 1.0	H = 2.9 K = 2.9 D _{ISO} = 1.4									
963898-2	D	3	CuFe2	4													
963898-1	D	3	CuSn4	4	0.2 - 0.35	1.15 - 1.6	E = 2.1 G = 2.1 D _{Dr} = 0.8	H = 2.9 K = 2.9 D _{ISO} = 1.4									
2141882-3	B	2	CuSn4	1													
2141882-2	A	2	CuFe2	4	0.2 - 0.35	1.15 - 1.6	E = 2.1 G = 2.1 D _{Dr} = 0.8	H = 2.9 K = 2.9 D _{ISO} = 1.4									
964265-5	A	3	CuSn4	5													
964265-3	D	3	CuSn4	1	0.2 - 0.35	1.15 - 1.6	E = 2.1 G = 2.1 D _{Dr} = 0.8	H = 2.9 K = 2.9 D _{ISO} = 1.4									
964265-2	C	3	CuFe2	4													

- 1 CONTACT AREA SELECTIVE GOLD 0.8µm MIN. OVER NICKEL.
WIRE CRIMP AREA ELECTRO TIN PLATED 1µm MIN. OVER NICKEL
Kontaktzone selectiv vergoldet 0.8µm min. ueber Ni
Drahtcrimpbereich gal. verzinkt 1µm min. ueber Ni
- 2 FOR DOUBLE- AND SINGLE TERMINATION fuer Doppel- und Einzelanschlaege
- 3 SINGLE WIRE SEAL TO BE SELECTED ACCORDING TO INSULATION-DIA ACCODING TO APPLICATION SPECIFICATION 114-18082
Auswahl der Eubzeldichtung entsprechend dem Isolationsdurchmesser nach Verarbeitungsspezifikation 114-18082
- 4 TIN PLATED vorverzinkt
- 5 CONTACT AREA SELECTIVE SILVER 3µm MIN. OVER NICKEL.
WIRE CRIMP AREA ELECTRO TIN PLATED 1.5µm MIN. OVER NICKEL
Kontaktzone selectiv versilbert 3µm min. ueber Ni
Drahtcrimpbereich gal. verzinkt 1.5µm min. ueber Ni
- 6 DIFFERENT TOOL DETAILS FUNCTION AND HANDLING WITH ALL DETAILS CONTINUOUSLY SUPPLY AFTER AVAILABILITY
Verschiedene Werkzeugausfuehrungen Funktion und Handhabung bei allen Ausfuehrungen gleich Lieferung nach Verfuegbarkeit

SEE APPLICATION SPECIFICATION 114-18082
siehe Verarbeitungsspezifikation 114-18082

TE ORDER-NO.	REV	DESIGN SERRATIONS / Ausführung Serrations	MATERIAL / Werkstoff	SURFACE / Oberfläche	DGB / mm ²	INSULATION / Isolations	STRIP FORM WIRE CRIMP / Drahtcrimp	INSUL. CRIMP / Isolationscrimp	BANDWARE	HAND TOOL / Handzange	INSERT / Matrize	A	B	C	X	TE ORDER-NO.	CRIMP DATA AND CRIMP TOOL / Crimpdaten und Crimpwerkzeuge
						mm	CRIMP DIMENSION mm / Crimpabmessungen mm					DIMENSION mm / Abmessung mm					

THIS DRAWING IS A CONTROLLED DOCUMENT. DWN: T.Bersch 11JUN1997
 CHK: U.Muenk 11JUN1997
 APPV: M.Bleicher 02MAR2011

STE TE Connectivity

PRODUCT GROUP DRAWING
 TAB 1.6 x 0.6 TYPE A
 Flachsstecker 1.6 x 0.6 Typ A

SIZE: A1 CAGE CODE: 00779 DRAWING NO: 114-18082
 WEIGHT: -
 SCALE: 10:1 SHEET 2 OF 2

MATERIAL: SEE TABLE sheet 2
 FINISH: SEE TABLE sheet 2
 TOLERANCES UNLESS OTHERWISE SPECIFIED: ±0.2

RESTRICTED TO: A21

Mouser Electronics

Authorized Distributor

Click to View Pricing, Inventory, Delivery & Lifecycle Information:

[TE Connectivity:](#)

[969028-5](#)