

THE INFORMATION CONTAINED IN THIS DRAWING IS THE SOLE PROPERTY OF ANDERSON POWER PRODUCTS. ANY REPRODUCTION IN PART OR WHOLE WITHOUT THE WRITTEN PERMISSION OF ANDERSON POWER PRODUCTS IS PROHIBITED.

Copyright 2009

ANDERSON POWER PRODUCTS RESERVES THE RIGHT TO ALTER PRODUCT TYPES, THEIR TECHNICAL DATA, DIMENSION, STYLE AND ACCESSORIES WITHOUT PRIOR NOTIFICATION.

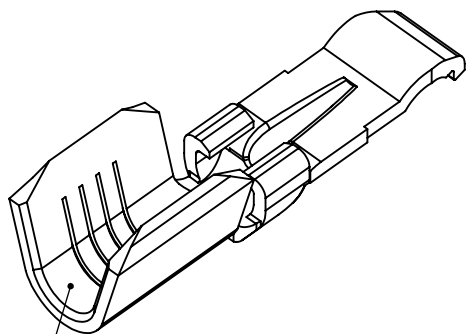

BARREL FOR  
#10-14 AWG WIRE

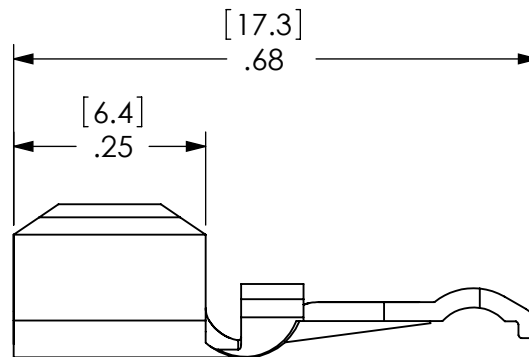
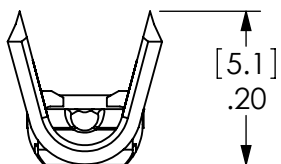
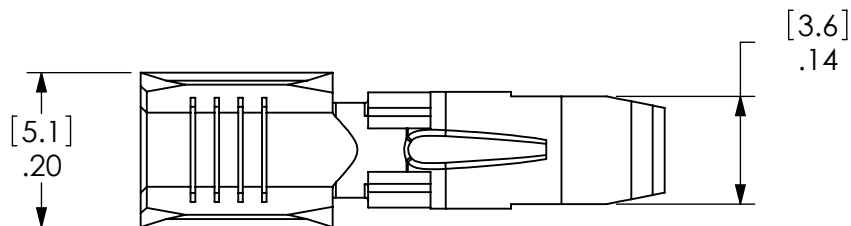

DIMENSIONS ARE IN:	INCH[MM]	<b>APPROVALS</b>	
UNLESS OTHERWISE STATED		DRAWN	NTS 6/18/09
TOLERANCES:		CHECKED	DJD 6/18/09
DECIMALS (INCH)	DECIMALS (MM)	ANGLES	MFG APP
.XX ± .02	.X ± .5	±2°	CHB 6/18/09
SURFACE FINISH:		QC APP	UFN 6/18/09
MACHINED	128 [3.2]	ENG APP	BD 6/18/09
MOLDED	64 [1.6]	MATERIAL: COPPER	
FINISH: SILVER PLATE		SIZE A/A4	

<b>ANDERSON POWER PRODUCTS</b>	
TITLE	CATALOG #261G3 PP45 REEL CONTACT TYPE "F" CRIMP
SCALE	NONE
DWG NO.	112718S7
REV.	0
CADFILE	02926
SHEET	1 OF 1

*****	*****	***	*****
REV.	DESCRIPTION OF CHANGES	APPROVED	DATE



-CAD GENERATED DRAWING-  
DO NOT MANUALLY UPDATE  
DO NOT SCALE

SCALE	NONE	CADFILE	02926	SHEET	1 OF 1
-------	------	---------	-------	-------	--------

# Mouser Electronics

Authorized Distributor

Click to View Pricing, Inventory, Delivery & Lifecycle Information:

[Anderson Power Products:](#)

[261G1](#) [261G1-LPBK](#) [261G3](#) [261G3-LPBK](#)