

ISL3034E, ISL3035E, ISL3036E

4-Channel And 6-Channel High Speed, Auto-direction Sensing Logic Level Translators

FN6492  
Rev 0.00  
March 31, 2009

The ISL3034E, ISL3035E, ISL3036E 4- and 6-channel bi-directional, auto-direction sensing, level translators provide the required level shifting in multi-voltage systems at data transfer rates up to 100Mbps. The auto-direction sensing feature makes the ISL3034E, ISL3035E, ISL3036E ideally suited for memory-card level translation (or for generic four to six channel level translation) especially if bit-by-bit direction control is desired. The  $V_{CC}$  and  $V_L$  supply voltages set the logic levels on either side of the device. Logic signals present on the IC's  $V_L$  side appear as higher voltage logic signals on the IC's  $V_{CC}$  side and vice versa. The ISL3035E features a CLK\_RET output that returns the same clock signal applied to the CLK\_VL input, but with timing that mimics the data returning from the I/OV<sub>CC</sub> inputs.

The ISL3034E, ISL3035E, ISL3036E operate at full speed with external input drivers that source as little as 4mA output current. Each I/O channel is pulled up to  $V_{CC}$  or  $V_L$  by an internal 30µA current source, allowing the ISL3034E, ISL3035E, ISL3036E to be driven by either push-pull or open-drain drivers.

The ISL3034E and ISL3036E include an enable (EN) input that when driven low places the IC into a low-power shutdown mode, with all I/O lines tri-stated. All versions feature an automatic shutdown mode, that places the part in the same shutdown state when  $V_{CC}$  is less than  $V_L$ . The states of I/OV<sub>CC</sub> and I/OV<sub>L</sub> during shutdown are chosen by selecting the appropriate product (see Table 1).

The ISL3034E, ISL3035E, ISL3036E operate with  $V_{CC}$  voltages from +2.2V to +3.6V and  $V_L$  voltages from +1.35V to +3.2V, making them ideal for data transfer between low-voltage microcontrollers or ASICs and higher voltage components.

TABLE 1. SUMMARY OF FEATURES

PART NUMBER	DATA RATE (Mbps)	NUMBER OF CHANNELS	EN PIN?	I/OV <sub>L</sub> SHDN STATE	I/OV <sub>CC</sub> SHDN STATE
ISL3034E	100	6	YES	16.5kΩ to $V_L$	16.5kΩ to $V_{CC}$
ISL3035E	100	6	NO	75kΩ to $V_L$	High Impedance
ISL3036E	100	4	YES	16.5kΩ to $V_L$	16.5kΩ to $V_{CC}$

**Features**

- Best-In-Class ESD Protection: ±15kV IEC61000-4-2 ESD Protection on ALL Input, Output, and I/O Lines
- 100Mbps Guaranteed Data Rate
- Four (ISL3036) or Six (ISL3034, ISL3035) Bi-directional Channels
- Auto-direction Sensing Eliminates Direction Control Logic Pins
- Enable Input (ISL3034E, ISL3036E) for Logic Control of Low Power SHDN Mode
- Clock Return Output (ISL3035E)
- Compatible with 4mA Input Drivers or Larger
- +1.35V ≤  $V_L$  ≤ +3.2V and +2.2V ≤  $V_{CC}$  ≤ +3.6V Supply Voltage Range
- Pb-Free (RoHS Compliant)
- 16Ld µTQFN (2.6mmx1.8mm), 16 Ld TQFN (3mmx3mm), and 14 Ld QFN (3.5mmx3.5mm) Packages

**Applications**

- Simplifies the Interface Between Two Logic ICs Operating at Different Supply Voltages
- SD Card and MiniSD Card Level Translation
- MMC (Multi Media Card) Level Translation
- Memory Stick Card Level Translation

**Typical Operating Circuit**

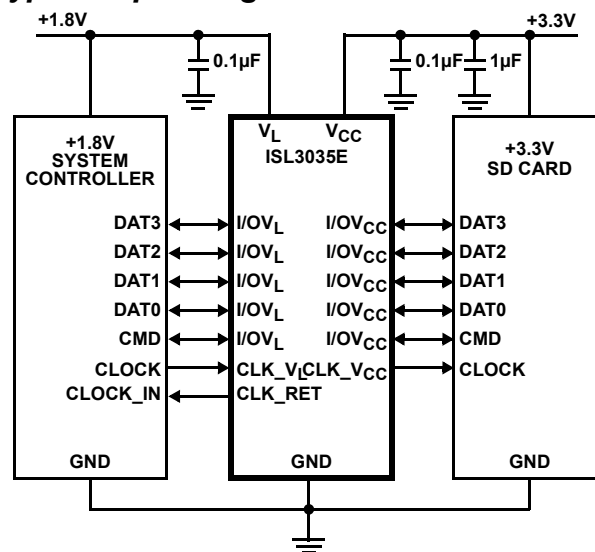

### Ordering Information

PART NUMBER	PART MARKING	TEMP. RANGE (°C)	PACKAGE (Pb-free)	PKG. DWG. #
ISL3034EIRTZ (Note 1)	34TZ	-40 to +85	16 Ld TQFN	L16.3x3A
ISL3034EIRTZ-T (Notes 1, 3)	34TZ	-40 to +85	16 Ld TQFN	L16.3x3A
ISL3034EIRUZ-T (Notes 2, 3)	GAE	-40 to +85	16 Ld $\mu$ TQFN	L16.2.6x1.8A
ISL3035EIRTZ (Note 1)	35TZ	-40 to +85	16 Ld TQFN	L16.3x3A
ISL3035EIRTZ-T (Notes 1, 3)	35TZ	-40 to +85	16 Ld TQFN	L16.3x3A
ISL3035EIRUZ-T (Notes 2, 3)	GAF	-40 to +85	16 Ld $\mu$ TQFN	L16.2.6x1.8A
ISL3036EIRZ-T (Notes 1, 3)	36EZ	-40 to +85	14 Ld QFN	L14.3.5x3.5
ISL3036EIRUZ-T (Notes 2, 3)	GAK	-40 to +85	16 Ld $\mu$ TQFN	L16.2.6x1.8A

NOTES:

1. These Intersil Pb-free plastic packaged products employ special Pb-free material sets, molding compounds/die attach materials, and 100% matte tin plate plus anneal (e3 termination finish, which is RoHS compliant and compatible with both SnPb and Pb-free soldering operations). Intersil Pb-free products are MSL classified at Pb-free peak reflow temperatures that meet or exceed the Pb-free requirements of IPC/JEDEC J STD-020.
2. These Intersil Pb-free plastic packaged products employ special Pb-free material sets; molding compounds/die attach materials and NiPdAu plate - e4 termination finish, which is RoHS compliant and compatible with both SnPb and Pb-free soldering operations. Intersil Pb-free products are MSL classified at Pb-free peak reflow temperatures that meet or exceed the Pb-free requirements of IPC/JEDEC J STD-020.
3. Please refer to TB347 for details on reel specifications.

### Pinouts

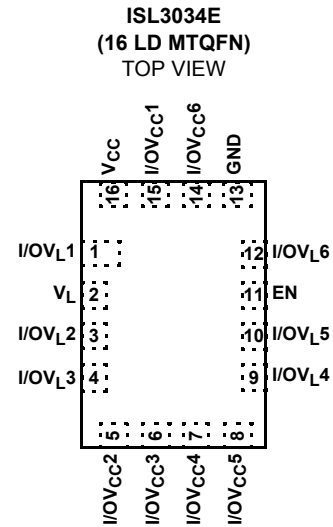
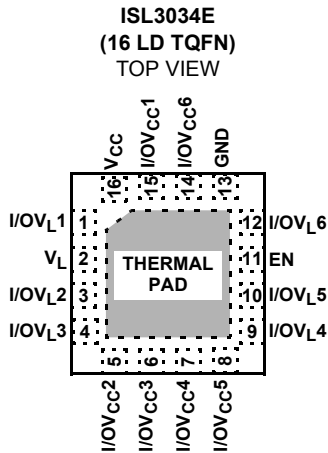

**Pinouts** (Continued)

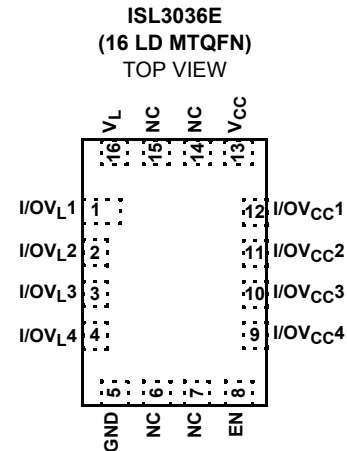
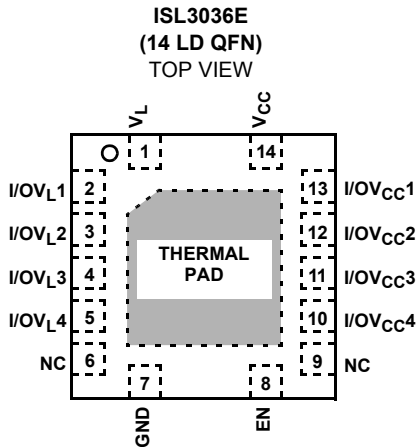
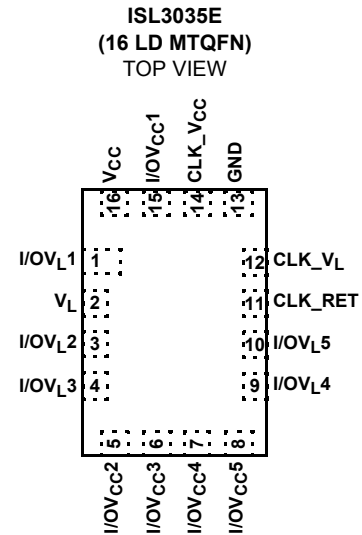
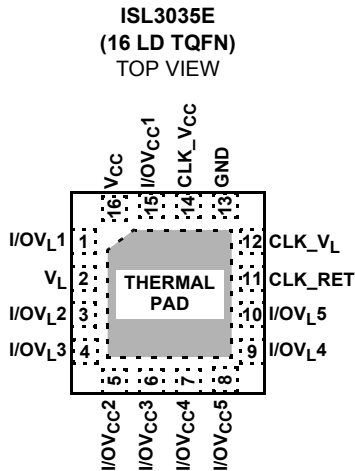

**Pin Descriptions**

NAME	FUNCTION	NOTES
V <sub>CC</sub>	V <sub>CC</sub> power supply, +2.2V to +3.6V. Decouple V <sub>CC</sub> to ground with a 0.1μF capacitor.	For normal operation, V <sub>CC</sub> > V <sub>L</sub> .
V <sub>L</sub>	V <sub>L</sub> logic supply, +1.35V to +3.2V. Decouple V <sub>L</sub> to ground with a 0.1μF capacitor.	For normal operation, V <sub>CC</sub> > V <sub>L</sub> .
GND	Ground Pin	
EN	±15kV IEC61000 ESD Protected Enable Input. Logic "0" puts the device in shutdown. Logic "1" enables the device.	ISL3034E and ISL3036E only
I/OV <sub>CC</sub> X	±15kV IEC61000 ESD Protected Input/Output channel referenced to V <sub>CC</sub> .	
CLK_V <sub>CC</sub>	±15kV IEC61000 ESD Protected Input/Output clock channel referenced to V <sub>CC</sub> .	ISL3035E only
I/OV <sub>L</sub> X	±15kV IEC61000 ESD Protected Input/Output channel referenced to V <sub>L</sub> .	
CLK_V <sub>L</sub>	IEC61000 ESD Protected Input clock channel referenced to V <sub>L</sub> .	ISL3035E only
CLK_RET	IEC61000 ESD Protected Output clock channel referenced to V <sub>L</sub> .	ISL3035E only

**Absolute Maximum Ratings**

(All voltages referenced to GND.)

$V_{CC}$ , $V_L$ .....	-0.3V to +4V
$I/OV_{CC}$ , $CLK\_V_{CC}$ .....	-0.3V to ( $V_{CC} + 0.3V$ )
$I/OV_L$ , $CLK\_V_L$ , $CLK\_RET$ .....	-0.3V to ( $V_L + 0.3V$ )
EN .....	-0.3V to +4V
Short-Circuit Duration $I/OV_L$ , $I/OV_{CC}$ , $CLK\_V_{CC}$ , $CLK\_RET$ to GND. ....	Continuous

**Operating Conditions**

Operating Temperature Range ..... -40°C to +85°C

**CAUTION:** Do not operate at or near the maximum ratings listed for extended periods of time. Exposure to such conditions may adversely impact product reliability and result in failures not covered by warranty.

**NOTES:**

- $\theta_{JA}$  is measured with the component mounted on a high effective thermal conductivity test board in free air, and with "direct attach" features for the QFN and TQFN. See Tech Brief TB379 for details.
- For  $\theta_{JC}$ , the "case temp" location is the center of the exposed metal pad on the package underside.

**Thermal Information**

Thermal Resistance (Typical)	$\theta_{JA}$ (°C/W)	$\theta_{JC}$ (°C/W)
14 Ld QFN Package (Notes 4, 5) .....	46	6
16 Ld TQFN Package (Notes 4, 5) .....	74	10
16 Ld $\mu$ TQFN Package (Note 4) .....	93	44
Maximum Storage Temperature Range .....	-65°C to +150°C	
Maximum Junction Temperature .....	+150°C	
Pb-free Reflow Profile .....	see link below <a href="http://www.intersil.com/pbfree/Pb-FreeReflow.asp">http://www.intersil.com/pbfree/Pb-FreeReflow.asp</a>	

**Electrical Specifications**  $V_{CC} = +2.2V$  to  $+3.6V$ ,  $V_L = +1.35V$  to  $+3.2V$ ,  $EN = V_L$ , unless otherwise noted. Typical values are at  $V_{CC} = +3.3V$ ,  $V_L = +1.8V$  and  $T_A = +25^\circ C$ . (Note 6).

PARAMETER	SYMBOL	TEST CONDITIONS	TEMP (°C)	MIN (Note 8)	TYP	MAX (Note 8)	UNITS
<b>POWER SUPPLIES</b>							
$V_L$ Supply Range	$V_L$	(Note 6)	Full	1.35	-	3.2	V
$V_{CC}$ Supply Range	$V_{CC}$	(Note 6)	Full	2.2	-	3.6	V
$V_{CC}$ Quiescent Supply Current	$I_{CC}$	$I/OV_{CC} = V_{CC}$ , $I/OV_L = V_L$	Full	-	18	30	$\mu A$
$V_L$ Quiescent Supply Current	$I_{VL}$	$I/OV_{CC} = V_{CC}$ , $I/OV_L = V_L$	Full	-	12	18	$\mu A$
$V_{CC}$ Shutdown Supply Current	$I_{CCSD}$	EN = GND or $V_L > V_{CC} + 0.7V$ ; ISL3034E and ISL3036E Only	Full	-	-	2.5	$\mu A$
		$V_L > V_{CC} + 0.7V$ ; ISL3035E Only	Full	-	-	2.5	$\mu A$
$V_L$ Shutdown Supply Current	$I_{LSD}$	EN = GND or $V_L > V_{CC} + 0.7V$ ; ISL3034E and ISL3036E Only	Full	-	-	4	$\mu A$
		$V_L > V_{CC} + 0.7V$ ; ISL3035E Only	Full	-	-	4	$\mu A$
$I/OV_{CC}$ , $CLK\_V_{CC}$ Tri-State Leakage Current	$I_{LKG}$	$V_L > V_{CC} + 0.7V$ , $V_O = 0V$ or $V_{CC}$ , ISL3035E Only	Full	-	0.1	2	$\mu A$
EN Input Current	$I_{IN\_EN}$	ISL3034E and ISL3036E Only	Full	-	-	1	$\mu A$
$V_L - V_{CC}$ Shutdown Threshold High	$V_{TH\_H}$	$V_{CC}$ rising	Full	-0.2	$0.05V_L$	0.7	V
$V_L - V_{CC}$ Shutdown Threshold Low	$V_{TH\_L}$	$V_{CC}$ falling	Full	-0.2	$0.1V_L$	0.7	V
$I/OV_{CC}$ , $I/OV_L$ Pull-up Resistance During Shutdown	$R_{PU\_SD1}$	EN = GND; ISL3034E and ISL3036E Only	Full	10	16.5	23	$k\Omega$
$I/OV_L$ , $CLK\_V_L$ , $CLK\_RET$ Pull-up Resistance During Shutdown	$R_{PU\_SD2}$	$V_L > (V_{CC} + 0.7V)$ ; ISL3035E Only	Full	45	75	105	$k\Omega$
$I/OV_L$ , $CLK\_V_L$ , $CLK\_RET$ Pull-up Current	$I_{VL\_PU}$	EN = $V_L$ , $I/OV_L = GND$	Full	20	-	75	$\mu A$
$I/OV_{CC}$ , $CLK\_V_{CC}$ Pull-up Current	$I_{VCC\_PU}$	EN = $V_L$ , $I/OV_{CC} = GND$	Full	20	-	75	$\mu A$
$I/OV_L$ to $I/OV_{CC}$ DC Resistance	$R_{ON}$		Full	-	3	-	$k\Omega$

**Electrical Specifications**  $V_{CC} = +2.2V$  to  $+3.6V$ ,  $V_L = +1.35V$  to  $+3.2V$ ,  $EN = V_L$ , unless otherwise noted. Typical values are at  $V_{CC} = +3.3V$ ,  $V_L = +1.8V$  and  $T_A = +25^\circ C$ . (Note 6). (Continued)

PARAMETER	SYMBOL	TEST CONDITIONS	TEMP (°C)	MIN (Note 8)	TYP	MAX (Note 8)	UNITS	
<b>ESD PROTECTION</b>								
All Input and I/O Pins From Pin to GND		IEC61000-4-2 Air-Gap Discharge	25	-	±15	-	kV	
		IEC61000-4-2 Contact Discharge	25	-	>±9	-	kV	
		Human Body Model	25	-	±15	-	kV	
All Pins		HBM, per JEDEC	25	-	>±12	-	kV	
		Machine Model, per JEDEC	25	-	±1300	-	V	
<b>LOGIC-LEVEL THRESHOLDS</b>								
I/OV <sub>L</sub> , CLK_V <sub>L</sub> Input Voltage High Threshold	V <sub>IHL</sub>	(Note 7)	Full	-	-	V <sub>L</sub> - 0.2	V	
I/OV <sub>L</sub> , CLK_V <sub>L</sub> Input Voltage Low Threshold	V <sub>ILL</sub>	(Note 7)	Full	0.15	-	-	V	
I/OV <sub>CC</sub> , CLK_V <sub>CC</sub> Input Voltage High Threshold	V <sub>IHC</sub>	(Note 7)	Full	-	-	V <sub>CC</sub> - 0.4	V	
I/OV <sub>CC</sub> , CLK_V <sub>CC</sub> Input Voltage Low Threshold	V <sub>ILC</sub>	(Note 7)	Full	0.2	-	-	V	
EN Input Voltage High Threshold	V <sub>IH</sub>		Full	-	-	V <sub>L</sub> - 0.4	V	
EN Input Voltage Low Threshold	V <sub>IL</sub>		Full	0.4	-	-	V	
I/OV <sub>L</sub> , CLK_RET Output Voltage High	V <sub>OHL</sub>	I <sub>OH</sub> = 20µA, I/OV <sub>CC</sub> ≥ V <sub>CC</sub> - 0.4V	Full	2/3 V <sub>L</sub>	-	-	V	
I/OV <sub>L</sub> , CLK_RET Output Voltage Low	V <sub>OLL</sub>	I <sub>OL</sub> = 20µA, I/OV <sub>CC</sub> ≤ 0.2V	Full	-	-	1/3 V <sub>L</sub>	V	
I/OV <sub>CC</sub> , CLK_V <sub>CC</sub> Output Voltage High	V <sub>OHC</sub>	I <sub>OH</sub> = 20µA, I/OV <sub>L</sub> ≥ V <sub>L</sub> - 0.2V	Full	2/3 V <sub>CC</sub>	-	-	V	
I/OV <sub>CC</sub> , CLK_V <sub>CC</sub> Output Voltage Low	V <sub>OLC</sub>	I <sub>OL</sub> = 20µA, I/OV <sub>L</sub> ≤ 0.15V	Full	-	-	1/3 V <sub>CC</sub>	V	
<b>RISE/FALL TIME ACCELERATOR STAGE</b>								
Accelerator Pulse Duration		On falling edge	25	-	3	-	ns	
		On rising edge	25	-	3	-	ns	
I/OV <sub>L</sub> , CLK_RET Output Accelerator Source Impedance		V <sub>L</sub> = 1.62V	25	-	11	-	Ω	
		V <sub>L</sub> = 3.2V	25	-	6	-	Ω	
I/OV <sub>CC</sub> , CLK_V <sub>CC</sub> Output Accelerator Source Impedance		V <sub>CC</sub> = 2.2V	25	-	9	-	Ω	
		V <sub>CC</sub> = 3.6V	25	-	8	-	Ω	
I/OV <sub>L</sub> , CLK_RET Output Accelerator Sink Impedance		V <sub>L</sub> = 1.62V	25	-	9	-	Ω	
		V <sub>L</sub> = 3.2V	25	-	8	-	Ω	
I/OV <sub>CC</sub> , CLK_V <sub>CC</sub> Output Accelerator Sink Impedance		V <sub>CC</sub> = 2.2V	25	-	10	-	Ω	
		V <sub>CC</sub> = 3.6V	25	-	9	-	Ω	
<b>TIMING CHARACTERISTICS</b> (R <sub>SOURCE</sub> = 150Ω, Input rise/fall time ≤ 1ns)								
I/OV <sub>CC</sub> , CLK_V <sub>CC</sub> Rise Time	t <sub>RVCC</sub>	R <sub>S</sub> = 150Ω, C <sub>I/OVCC</sub> = 10pF, C <sub>CLK_VCC</sub> = 10pF, push-pull drivers	Full	-	-	3.2	ns	
I/OV <sub>CC</sub> , CLK_V <sub>CC</sub> Fall Time	t <sub>FVCC</sub>	R <sub>S</sub> = 150Ω, C <sub>I/OVCC</sub> = 10pF, C <sub>CLK_VCC</sub> = 10pF	Full	-	-	3.2	ns	
I/OV <sub>L</sub> , CLK_RET Rise Time	t <sub>RVL</sub>	R <sub>S</sub> = 150Ω, C <sub>I/OVL</sub> = 15pF, C <sub>CLK_RET</sub> = 15pF, push-pull drivers	V <sub>L</sub> ≥ 1.35V	Full	-	-	4	ns
			V <sub>L</sub> ≥ 1.62V	Full	-	-	3.5	ns

**Electrical Specifications**  $V_{CC} = +2.2V$  to  $+3.6V$ ,  $V_L = +1.35V$  to  $+3.2V$ ,  $EN = V_L$ , unless otherwise noted. Typical values are at  $V_{CC} = +3.3V$ ,  $V_L = +1.8V$  and  $T_A = +25^\circ C$ . (Note 6). (Continued)

PARAMETER	SYMBOL	TEST CONDITIONS	TEMP (°C)	MIN (Note 8)	TYP	MAX (Note 8)	UNITS	
I/OV <sub>L</sub> , CLK_RET Fall Time	t <sub>FVL</sub>	R <sub>S</sub> = 150Ω, C <sub>I/OVL</sub> = 15pF, C <sub>CLK_RET</sub> = 15pF	V <sub>L</sub> ≥ 1.35V	Full	-	-	4	ns
			V <sub>L</sub> ≥ 1.62V	Full	-	-	3.5	ns
I/OV <sub>CC</sub> , CLK_V <sub>CC</sub> Propagation Delay (Driving I/OV <sub>L</sub> , CLK_V <sub>L</sub> )	t <sub>PDVCC</sub>	R <sub>S</sub> = 150Ω, C <sub>I/OVCC</sub> = 10pF, C <sub>CLK_VCC</sub> = 10pF, push-pull drivers	V <sub>L</sub> ≥ 1.35V	Full	-	-	7.5	ns
			V <sub>L</sub> ≥ 1.62V	Full	-	-	6.5	ns
t <sub>PDVCC</sub> Channel-to-Channel Skew (Note 9)	t <sub>SKEWC</sub>		V <sub>L</sub> ≥ 1.35V	Full	-	-	1.3	ns
			V <sub>L</sub> ≥ 1.62V	Full	-	-	1	ns
I/OV <sub>L</sub> , CLK_RET Propagation Delay (Driving I/OV <sub>CC</sub> , CLK_V <sub>CC</sub> )	t <sub>PDVL</sub>	R <sub>S</sub> = 150Ω, C <sub>I/OVL</sub> = 15pF, C <sub>CLK_RET</sub> = 15pF, push-pull drivers	Full	-	-	6.5	ns	
t <sub>PDVL</sub> Channel-to-Channel Skew (Note 9)	t <sub>SKEWL</sub>		V <sub>L</sub> ≥ 1.35V	Full	-	-	1.3	ns
			V <sub>L</sub> ≥ 1.62V	Full	-	-	0.8	ns
Delay from EN High to I/OV <sub>CC</sub> Active	t <sub>EN-VCC</sub>	R <sub>LOAD</sub> = 1MΩ, C <sub>I/OVCC</sub> = 10pF (ISL3034E and ISL3036E)	25	-	1.5	-	μs	
Delay from EN High to I/OV <sub>L</sub> Active	t <sub>EN-VL</sub>	R <sub>LOAD</sub> = 1MΩ, C <sub>I/OVL</sub> = 15pF (ISL3034E and ISL3036E)	25	-	1.5	-	μs	
Maximum Data Rate	D.R.1.35	Push-pull operation, R <sub>SOURCE</sub> = 150Ω, C <sub>I/OVCC</sub> = 10pF, C <sub>I/OVL</sub> = 15pF, C <sub>CLK_VCC</sub> = 10pF, C <sub>CLK_RET</sub> = 15pF	V <sub>L</sub> ≥ 1.35V	Full	85	-	-	Mbps
	D.R.1.6		V <sub>L</sub> ≥ 1.62V	Full	100	-	-	Mbps

NOTES:

- V<sub>L</sub> must be less than or equal to V<sub>CC</sub> - 0.2V during normal operation. However, V<sub>L</sub> can be greater than V<sub>CC</sub> during start-up and shutdown conditions and the part will not latch-up nor be damaged.
- Input thresholds are referenced to the boost circuit.
- Parameters with MIN and/or MAX limits are 100% tested at +25°C, unless otherwise specified. Temperature limits established by characterization and are not production tested.
- Delta between all I/OV<sub>L</sub> channel prop delays, or delta between all I/OV<sub>CC</sub> channel prop delays, all channels tested at the same test conditions.

**Test Circuits and Waveforms**

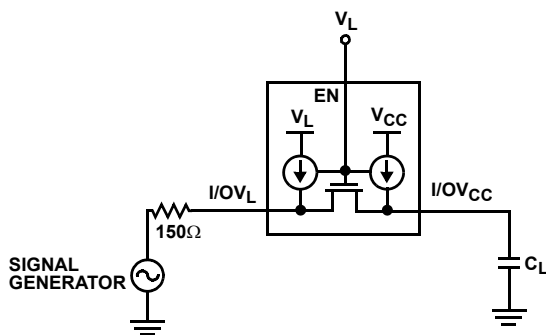

FIGURE 1A. TEST CIRCUIT

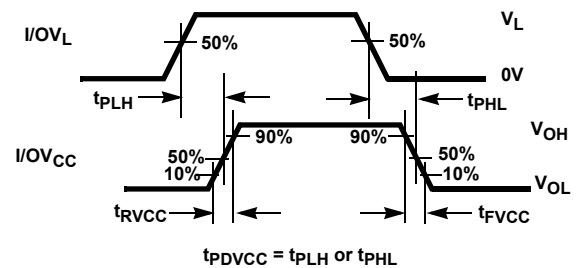

FIGURE 1B. MEASUREMENT POINTS

FIGURE 1. I/OV<sub>CC</sub> OUTPUT PROPAGATION DELAY AND TRANSITION TIMES (PUSH - PULL)

**Test Circuits and Waveforms** (Continued)

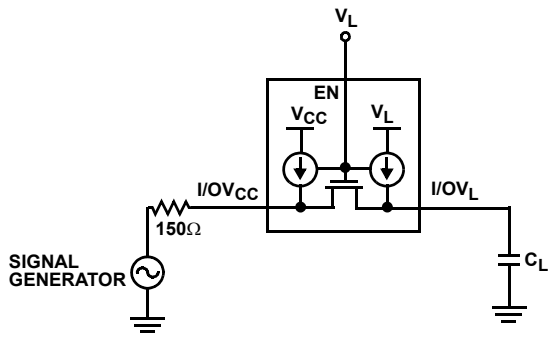

FIGURE 2A. TEST CIRCUIT

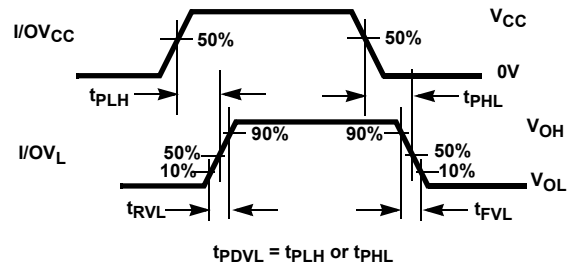
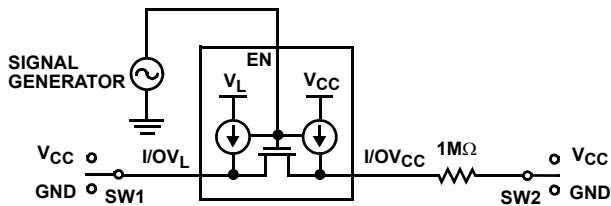

FIGURE 2B. MEASUREMENT POINTS

FIGURE 2. I/OV<sub>L</sub> OUTPUT PROPAGATION DELAY AND TRANSITION TIMES (PUSH - PULL)



PARAMETER	SW1	SW2
t <sub>ENL</sub>	GND	V <sub>CC</sub>
t <sub>ENH</sub>	V <sub>CC</sub>	GND

FIGURE 3A. TEST CIRCUIT

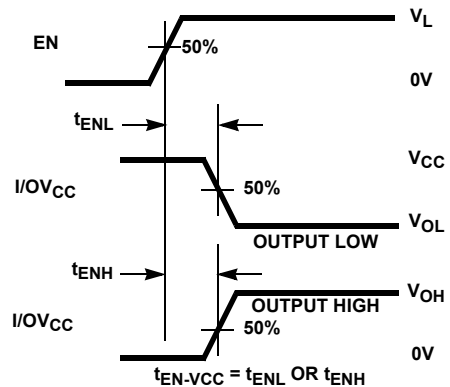
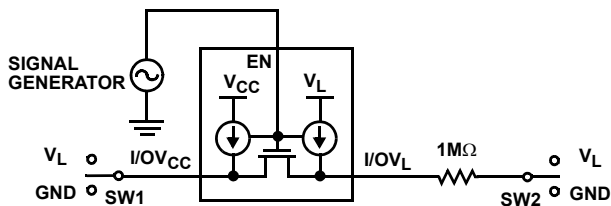

FIGURE 3B. MEASUREMENT POINTS

FIGURE 3. I/OV<sub>CC</sub> OUTPUT ENABLE TIMES



PARAMETER	SW1	SW2
t <sub>ENL</sub>	GND	V <sub>L</sub>
t <sub>ENH</sub>	V <sub>L</sub>	GND

FIGURE 4A. TEST CIRCUIT

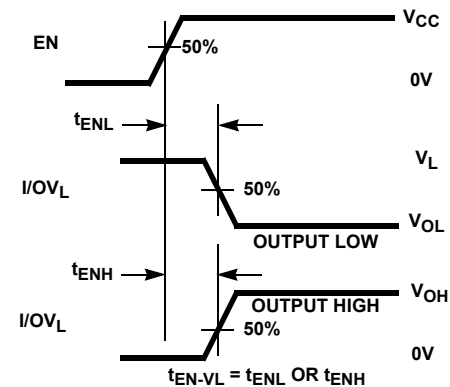

FIGURE 4B. MEASUREMENT POINTS

FIGURE 4. I/OV<sub>L</sub> OUTPUT ENABLE TIMES

## Application Information

### Overview

The ISL3034E, ISL3035E, ISL3036E are 100Mbps, bi-directional voltage level translating ICs for multi-supply voltage systems. These products shift lower voltage levels on one interface side (supplied by  $V_L$ ) to a higher voltage level on the other interface side (supplied by  $V_{CC}$ ), or vice versa.  $V_{OH}$  of the  $I/OV_L$  pins tracks the  $V_L$  supply, while  $V_{OH}$  of the  $I/OV_{CC}$  pins tracks the  $V_{CC}$  supply.

These ICs feature bit-by-bit auto-direction sensing to increase flexibility, and to eliminate the need for direction control pins. On chip pull-up current sources in the active mode, and pull-up resistors in SHDN mode, eliminate the need for most external bus resistors. Drivers interfacing with these level translators may be open-drain or push-pull types, and all three versions may also be used for unidirectional level shifting.

The three versions share the same architecture, but the ISL3034E is a general purpose 6-Channel version, while the 6-Channel ISL3035E specifically targets SD Card and other memory card applications. The 4-channel ISL3036 targets nibble and byte based applications, as well as 4-wire SPI interfaces. Power supply ranges allow level shifting between 1.5V, 1.8V, and 2.5V powered devices on the  $V_L$  side to 2.5V, and 3.3V devices on the  $V_{CC}$  side.

### Principles of Operation

When enabled, these level shifters detect transitions on an I/O pin, and drive the appropriate logic level on the corresponding I/O pin on the other “side”. If the transition was low-to-high, the channel shifts the voltage up to  $V_{CC}$  (for transitions on an  $I/OV_L$  pin) or down to  $V_L$  (for transitions on an  $I/OV_{CC}$  pin), and then drives the shifted level on the other side. The ISL3035E enables whenever  $V_{CC} > V_L + 200\text{mV}$ , while the ISL3034E and ISL3036E enable if  $EN = 1$  AND  $V_{CC} > V_L + 200\text{mV}$ .

Upon detecting a transition on either I/O pin, that channel's accelerator circuitry actively drives the opposite side's (output) pin to GND or the output's supply rail, and then turns off. Weak hold circuitry then maintains the logic state until the input is 3-stated, or until another active transition occurs on either I/O pin for that channel. Figure 5 shows the simplified block diagram of one level shifting channel. The accelerator circuitry comprises high and low threshold detectors, one shots with level shifters and large output drivers. A transition on one of the  $I/OV_L$  or  $I/OV_{CC}$  pins momentarily defines that pin as an input. When the high or low threshold is crossed, a one-shot fires either the PMOS or NMOS driver, respectively, on the opposite side (effectively the output). These drivers are large enough to quickly drive the output node to its respective supply or to GND. Note that this transition on the “output” trips the transition detector on that pin, firing its accelerator, which feeds back to the “input” to help reinforce slow transitions, such as those from an open-drain type driver. Once the one-shot - and thus the accelerator - times out (approximately 3ns to 4ns), the large output drivers tri-state and the pins are weakly held in the

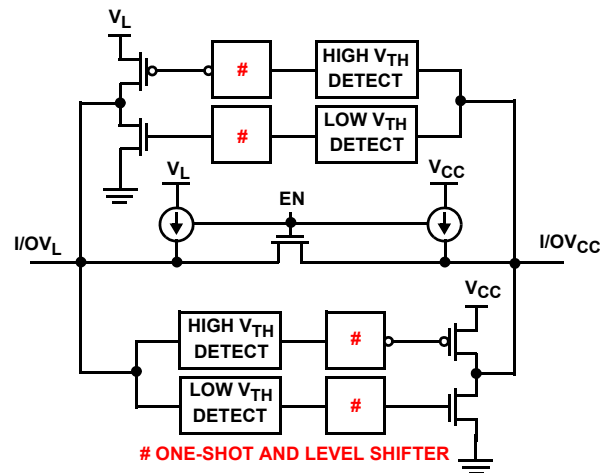

FIGURE 5. ONE CHANNEL SIMPLIFIED SCHEMATIC

last state by the small NMOS transistor between  $I/OV_L$  and  $I/OV_{CC}$  (for a low) or by the small current sources (for a high). In this static state, the I/O pins are easily overdriven by the next transition from an external driver. Having large pull-up and pull-down devices in the accelerator (vs just an active pull-up) nearly eliminates the concern about the external driver's output impedance, and that impedance's effect on  $V_{OL}$ , fall times and data rate.

The weak pull-up current sources on each I/O pin and the NMOS pass transistors, remain ON whenever the IC is enabled. If a channel's external driver tri-states, the weak pull-up currents either keep the I/O pins high, or if the last state was a low the current sources pull the I/O pins high. In the latter case, each channel's accelerators will once again fire when either the  $I/OV_L$  or the  $I/OV_{CC}$  voltage crosses the accelerator's high threshold level.

### Auto Direction Sensing

Each level translator channel independently and automatically determines the direction of data transfer without any external control signals. As described earlier, a transition on either of the channel's I/O pins momentarily defines that pin as an input, which then translates and drives that input signal to the channel's corresponding pin on the other port (now the output). After a brief period of active driving, both I/O pins return to their weak “hold” mode, where the next transition on either I/O pin determines the direction for the next transfer.

Auto sensing saves valuable processor GPIO pins (three [CLK, CMD, DAT] for SD Card applications, or six for the general purpose hex case), and simplifies the software associated with the peripheral interface.

### Using Open Drain Drivers

These level translators' accelerator based architecture works equally well when driven by push-pull or open drain type drivers (e.g., for the CMD line initialization in MMC applications). The low static pull-up current is easily overdriven by an active pull-down, and the feedback nature of the accelerators (i.e., the accelerator firing in one direction also triggers the accelerator in the opposite direction) aids the



passive pull-up once the input signal passes the accelerator's high threshold. The pull-up current and load capacitance set the input signal rise time, and thus the maximum data rate. For slow data rates the internal pull-up current may suffice, but higher data rates - or more heavily loaded signal lines - may require an external pull-up resistor.

### Using External Bus Resistors

As mentioned earlier, these level translators incorporate I/O pin pull-up current sources when enabled, and I/O pin pull-up resistors in SHDN (except for the ISL3035E's I/OV<sub>CC</sub> pins). Therefore, external pull-up or pull-down resistors shouldn't be necessary, and aren't recommended, unless using high-speed open drain signaling.

### Power Supplies

#### WIDE SUPPLY RANGE

These ICs operate from a wide range of supply voltages. V<sub>L</sub> is designed to connect to the supply of 1.5V, 1.8V, and 2.5V powered devices, while V<sub>CC</sub> is targeted for 2.5V, and 3.3V components. Remember that V<sub>CC</sub> must be greater than V<sub>L</sub> for proper operation.

#### POWER SUPPLY SEQUENCING

Either V<sub>CC</sub> or V<sub>L</sub> may be powered up first, but the IC remains in SHDN until V<sub>CC</sub> exceeds V<sub>L</sub> by as much as 200mV. V<sub>L</sub> may exceed V<sub>CC</sub> by as much as 4V without causing any damage.

#### I/O PIN INPUT THRESHOLDS VS SUPPLY VOLTAGE

Even though the "Electrical Specification" table on page 4 shows the I/O pin input thresholds (V<sub>IH</sub>, V<sub>IL</sub>) with a fixed delta from the supplies or GND, the thresholds are better represented as a percentage of the supplies. The typical I/OV<sub>CC</sub> and CLK\_V<sub>CC</sub> V<sub>IH</sub> runs about 55% to 60% of V<sub>CC</sub>, while the corresponding V<sub>IL</sub> runs about 33% of V<sub>CC</sub>. The typical I/OV<sub>L</sub> and CLK\_V<sub>L</sub> V<sub>IH</sub> runs about 60% to 70% of V<sub>L</sub>, while the corresponding V<sub>IL</sub> runs about 25% to 35% of V<sub>L</sub>.

#### Low Power SHDN Mode

This family of level translators features a low power SHDN mode that tri-states all the I/O and output pins, considerably reduces current consumption, and enables any pull-up resistors on a port's I/O pins (see Table 1). The ISL3034E and ISL3036E enter the SHDN mode when the EN input switches low, or automatically when the V<sub>CC</sub> voltage drops below the V<sub>L</sub> voltage. The ISL3035 has no enable pin, so it enters SHDN only if V<sub>CC</sub> drops below V<sub>L</sub>. The V<sub>L</sub> supply powers the EN circuitry.

#### ISL3034E and ISL3036E

The ISL3034E and ISL3036E are general purpose level translators featuring an enable pin, and six or four channels, respectively. Both products include SHDN mode 16.5kΩ pull-ups on the I/OV<sub>CC</sub> and I/OV<sub>L</sub> pins.

#### ISL3035E

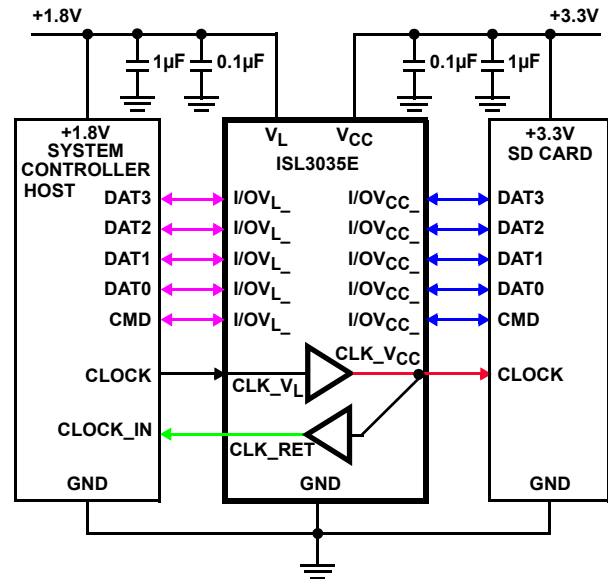

FIGURE 6. ISL3035E IN AN SD CARD APPLICATION

The ISL3035E specifically targets memory card applications, and Figure 6 illustrates its use in an SD Card application. Instead of six general purpose channels, the ISL3035E features five general purpose channels and one dedicated CLK channel. In memory card applications, the CLK channel is a unidirectional signal driven by the host controller and used by the memory card to synchronize data reads and writes. The ISL3035E's CLK channel is unique in that the host CLK applied to the CLK\_V<sub>L</sub> pin routes to the memory card via the CLK\_V<sub>CC</sub> pin, but it also loops back to the host on the CLK\_RET pin. This CLK\_RET signal better mimics the timing of "read" data returned from the memory card (see Figure 21 for signal timing), so using CLK\_RET as the host's input CLK improves the CLK to data timing relationship.

CLK\_RET is strictly an output, and CLK\_V<sub>L</sub> is strictly an input. If an ISL3035E application needs a sixth I/O channel then the user needs to connect CLK\_V<sub>L</sub> and CLK\_RET together. Connected this way, the combination channel has the same architecture as the other I/O channels. Both CLK\_RET and CLK\_V<sub>L</sub> have equivalent pull-up current sources and SHDN pull-up resistors, so connecting these two pins together doubles the pull-up current in either mode.

The bit-by-bit auto direction control eliminates the need for GPIO signals to control the flow of data on the CMD and DAT lines.

The ISL3035E has no enable pin, so it only enters the low power SHDN mode when V<sub>CC</sub> drops below V<sub>L</sub>. There are no SHDN pull-up resistors on the I/OV<sub>CC</sub> and CLK\_V<sub>CC</sub> pins, but there are 75kΩ pull-ups on the I/OV<sub>L</sub>, CLK\_V<sub>L</sub>, and CLK\_RET pins.

**Best-in-Class ESD Protection**

All pins on these devices include class 3 (>12kV) Human Body Model (HBM) ESD protection structures, but the input and I/O pins incorporate advanced structures allowing them to survive ESD events in excess of ±15kV HBM and ±15kV to IEC61000-4-2. The I/OV<sub>CC</sub> pins are particularly vulnerable to ESD damage because they typically connect to an exposed port on the exterior of the finished product. Simply touching the port pins, or connecting a memory card, can cause an ESD event that might destroy unprotected ICs. These new ESD structures protect the device whether or not it is powered up and without degrading the level shifting performance. This built-in ESD protection eliminates the need for board level protection structures (e.g., transient suppression diodes) and the associated, undesirable capacitive load they present. To ensure the full benefit of the built-in ESD protection, connect the IC’s GND pin directly to a low impedance GND plane.

**IEC61000-4-2 Testing**

The IEC61000 test method applies to finished equipment, rather than to an individual IC. Therefore, the pins most likely to suffer an ESD event are those that are exposed to the outside world (typically I/OV<sub>CC</sub> pins in memory card applications) but the ISL3034E, ISL3035E, and ISL3036E feature IEC61000 ESD protection on all logic and I/O pins (both I/OV<sub>L</sub> and I/OV<sub>CC</sub>, as well as CLK pins). Unlike HBM and MM methods which only test each pin-to-pin combination without applying power, IEC61000 testing is also performed with the IC in its typical application configuration (power

applied). The IEC61000 standard’s lower current limiting resistor coupled with the larger charge storage capacitor yields a test that is much more severe than the HBM test. The extra ESD protection built into these devices’ pins allows the design of equipment meeting level 4 criteria without the need for additional board level protection.

**AIR-GAP DISCHARGE TEST METHOD**

For this test method, a charged probe tip moves toward the IC pin until the voltage arcs to it. The current waveform delivered to the IC pin depends on approach speed, humidity, temperature, etc., so it is difficult to obtain repeatable results. All the EN, CLK, and I/O pins withstand ±15kV air-gap discharges, relative to GND.

**CONTACT DISCHARGE TEST METHOD**

During the contact discharge test, the probe contacts the tested pin before the probe tip is energized, thereby eliminating the variables associated with the air-gap discharge. The result is a more repeatable and predictable test, but equipment limits prevent testing devices at voltages higher than ±9kV. Devices in this family survive ±9kV contact discharges (relative to the GND pin) on the EN, CLK, and I/O pins.

**Layout and Decoupling Considerations**

These level translators’ high data rates and fast signal transitions require that the accelerators have high transient currents. Thus, short, low inductance supply traces and decoupling within 1/8th inch of the IC are imperative with very low impedance GND return paths.

**Typical Performance Curves**

V<sub>CC</sub> = 3.3V, V<sub>L</sub> = 1.8V, C<sub>L</sub> = 15pF, R<sub>SOURCE</sub> = 150Ω, Data Rate = 100Mbps, push-pull driver, T<sub>A</sub> = +25°C; Unless Otherwise Specified.

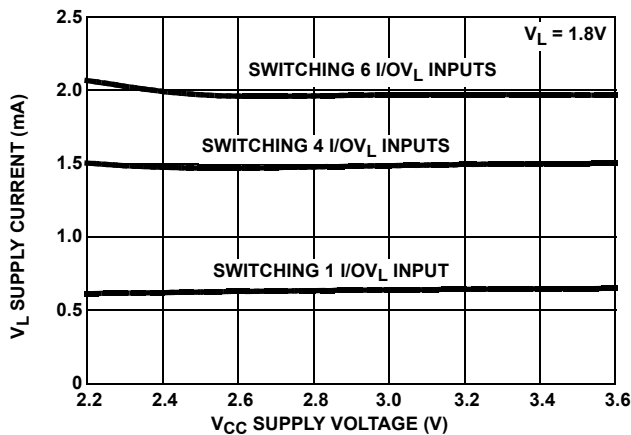

FIGURE 7. V<sub>L</sub> SUPPLY CURRENT vs V<sub>CC</sub> SUPPLY VOLTAGE

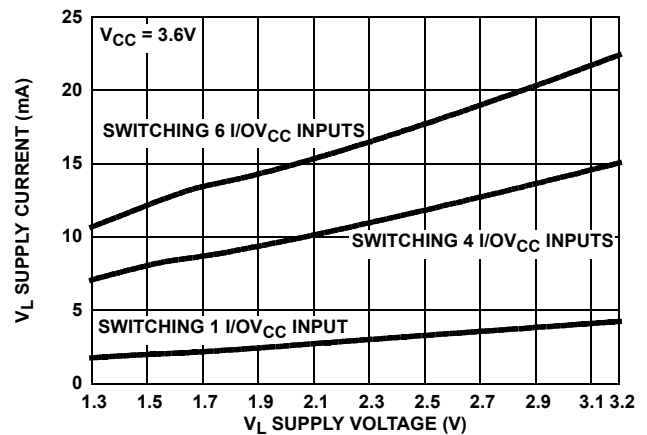

FIGURE 8. V<sub>L</sub> SUPPLY CURRENT vs V<sub>L</sub> SUPPLY VOLTAGE

**Typical Performance Curves**

$V_{CC} = 3.3V$ ,  $V_L = 1.8V$ ,  $C_L = 15pF$ ,  $R_{SOURCE} = 150\Omega$ , Data Rate = 100Mbps, push-pull driver,  $T_A = +25^\circ C$ ; Unless Otherwise Specified. (Continued)

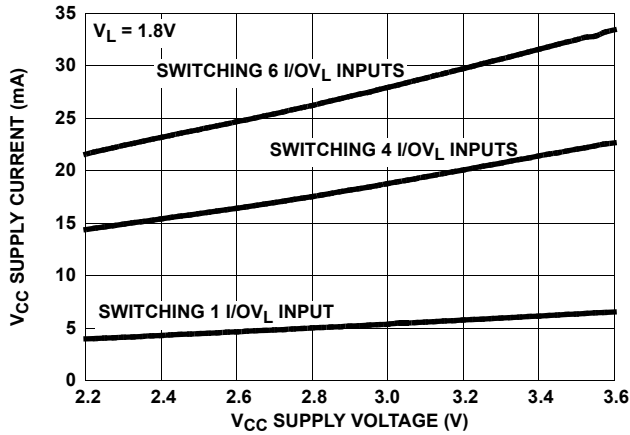

FIGURE 9.  $V_{CC}$  SUPPLY CURRENT vs  $V_{CC}$  SUPPLY VOLTAGE

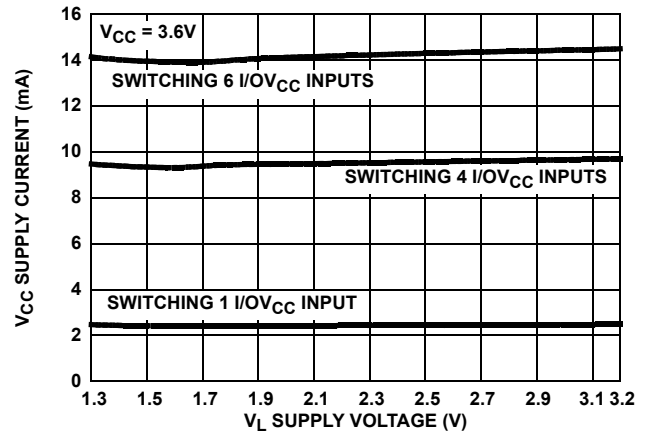

FIGURE 10.  $V_{CC}$  SUPPLY CURRENT vs  $V_L$  SUPPLY VOLTAGE

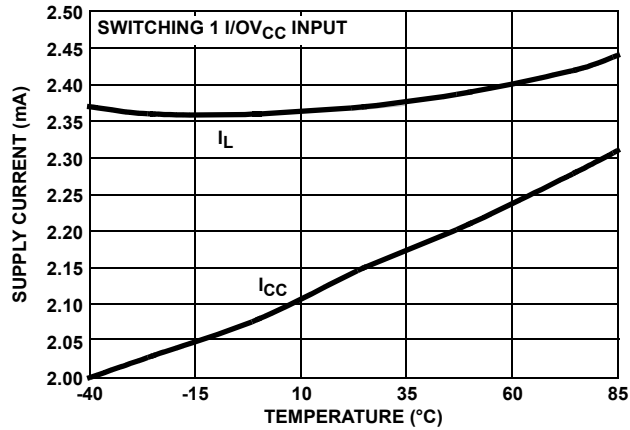

FIGURE 11. SUPPLY CURRENT vs TEMPERATURE

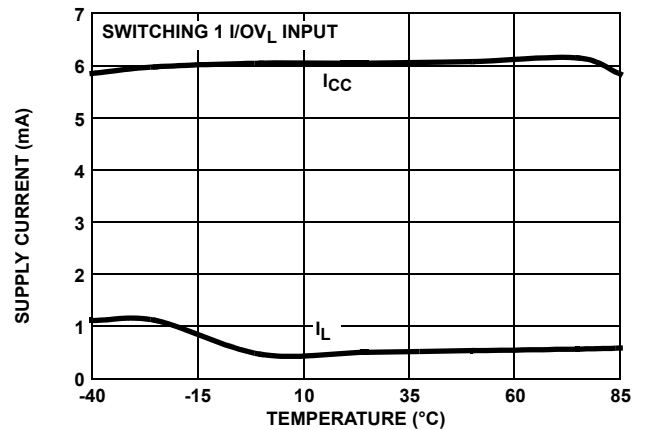

FIGURE 12. SUPPLY CURRENT vs TEMPERATURE

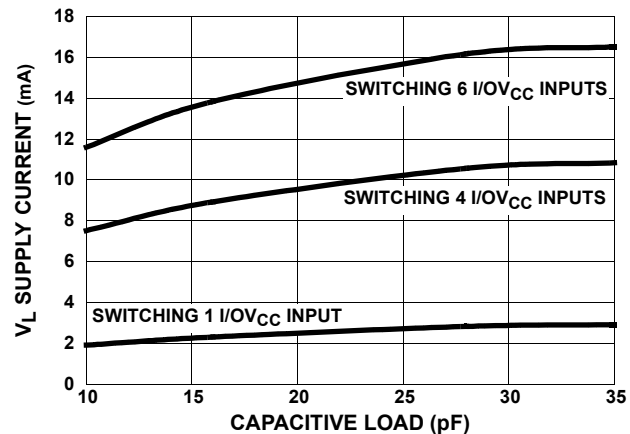

FIGURE 13.  $V_L$  SUPPLY CURRENT vs I/OVL CAPACITIVE LOAD

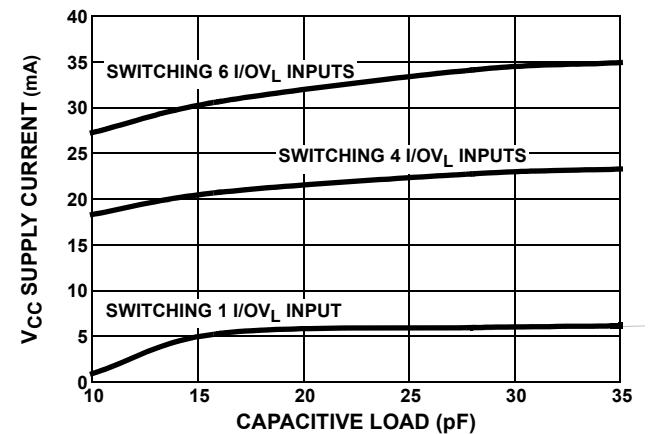

FIGURE 14.  $V_{CC}$  SUPPLY CURRENT vs I/OVCC CAPACITIVE LOAD

**Typical Performance Curves**

$V_{CC} = 3.3V$ ,  $V_L = 1.8V$ ,  $C_L = 15pF$ ,  $R_{SOURCE} = 150\Omega$ , Data Rate = 100Mbps, push-pull driver,  $T_A = +25^\circ C$ ; Unless Otherwise Specified. (Continued)

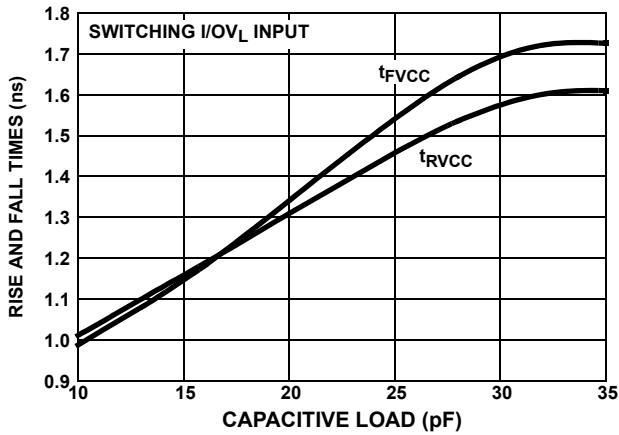

FIGURE 15. RISE/FALL TIME vs I/OV<sub>CC</sub> CAPACITIVE LOAD

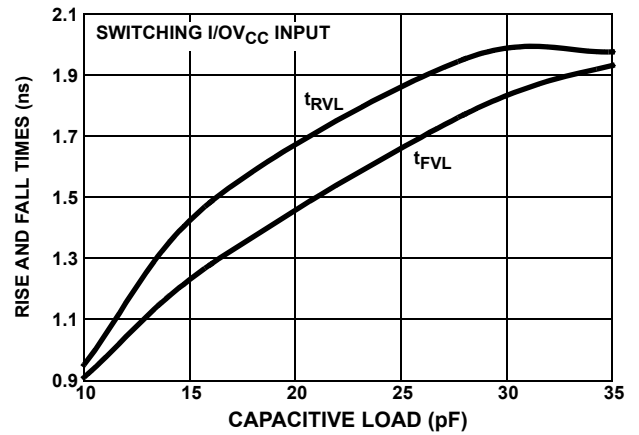

FIGURE 16. RISE/FALL TIME vs I/OV<sub>L</sub> CAPACITIVE LOAD

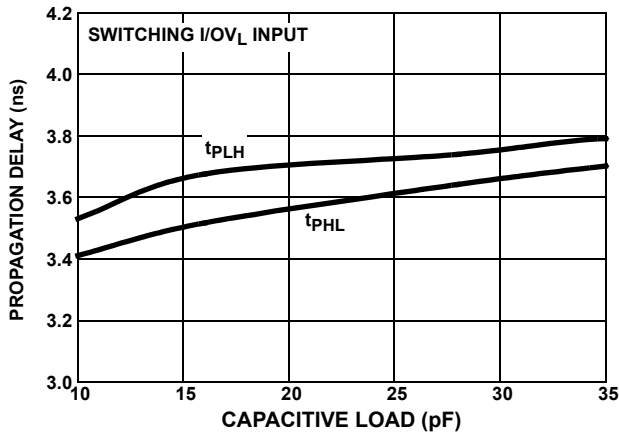

FIGURE 17. PROPAGATION DELAY vs I/OV<sub>CC</sub> CAPACITIVE LOAD

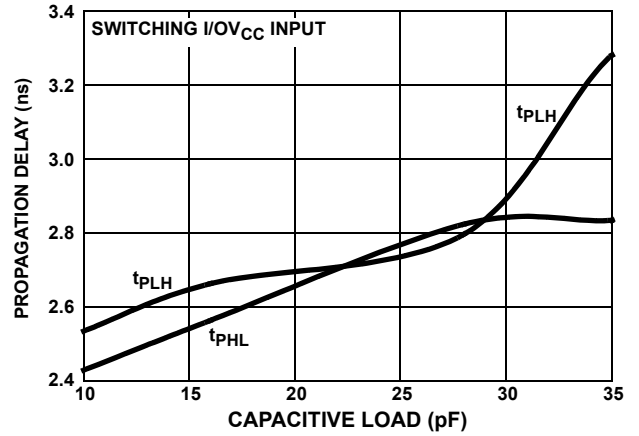

FIGURE 18. PROPAGATION DELAY vs I/OV<sub>L</sub> CAPACITIVE LOAD

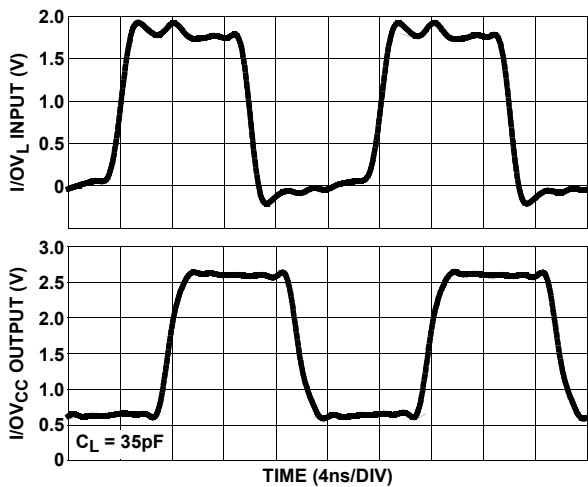

FIGURE 19. I/OV<sub>CC</sub> OUTPUT WAVEFORMS (100Mbps)

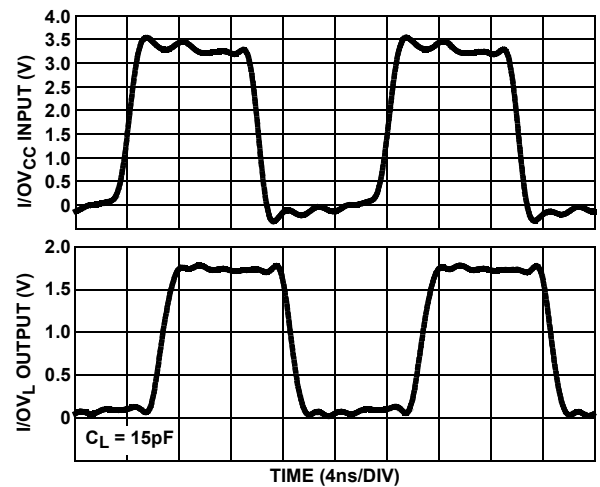

FIGURE 20. I/OV<sub>L</sub> OUTPUT WAVEFORMS (100Mbps)

**Typical Performance Curves**

$V_{CC} = 3.3V$ ,  $V_L = 1.8V$ ,  $C_L = 15pF$ ,  $R_{SOURCE} = 150\Omega$ , Data Rate = 100Mbps, push-pull driver,  $T_A = +25^\circ C$ ; Unless Otherwise Specified. (Continued)

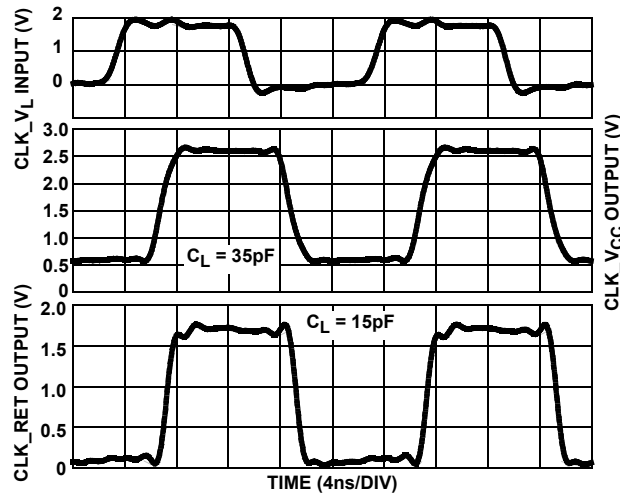

FIGURE 21. ISL3035E CLOCK WAVEFORMS (100Mbps)

**Die Characteristics**

**SUBSTRATE AND TQFN/QFN THERMAL PAD POTENTIAL (POWERED UP):**

GND

**TRANSISTOR COUNT:**

ISL3034E, ISL3035E - 2600

ISL3036E - 2000

**PROCESS:**

Si Gate BiCMOS

© Copyright Intersil Americas LLC 2009. All Rights Reserved.

All trademarks and registered trademarks are the property of their respective owners.

For additional products, see [www.intersil.com/en/products.html](http://www.intersil.com/en/products.html)

Intersil products are manufactured, assembled and tested utilizing ISO9001 quality systems as noted in the quality certifications found at [www.intersil.com/en/support/qualandreliability.html](http://www.intersil.com/en/support/qualandreliability.html)

*Intersil products are sold by description only. Intersil may modify the circuit design and/or specifications of products at any time without notice, provided that such modification does not, in Intersil's sole judgment, affect the form, fit or function of the product. Accordingly, the reader is cautioned to verify that datasheets are current before placing orders. Information furnished by Intersil is believed to be accurate and reliable. However, no responsibility is assumed by Intersil or its subsidiaries for its use; nor for any infringements of patents or other rights of third parties which may result from its use. No license is granted by implication or otherwise under any patent or patent rights of Intersil or its subsidiaries.*

For information regarding Intersil Corporation and its products, see [www.intersil.com](http://www.intersil.com)

**Ultra Thin Quad Flat No-Lead Plastic Package (UTQFN)**

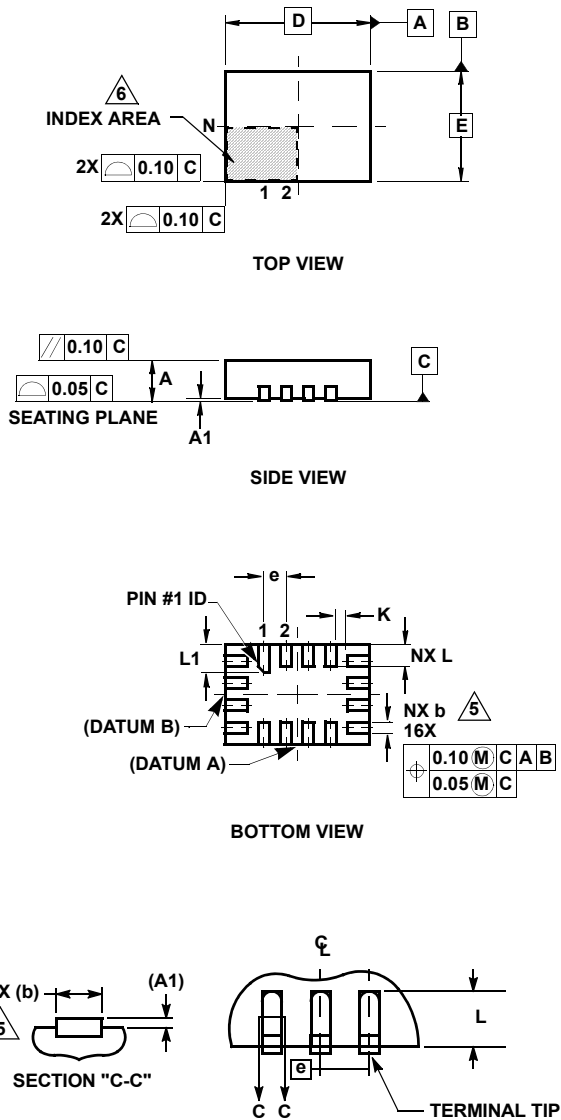

**L16.2.6x1.8A**

**16 LEAD ULTRA THIN QUAD FLAT NO-LEAD PLASTIC PACKAGE**

SYMBOL	MILLIMETERS			NOTES
	MIN	NOMINAL	MAX	
A	0.45	0.50	0.55	-
A1	-	-	0.05	-
A3	0.127 REF			-
b	0.15	0.20	0.25	5
D	2.55	2.60	2.65	-
E	1.75	1.80	1.85	-
e	0.40 BSC			-
K	0.15	-	-	-
L	0.35	0.40	0.45	-
L1	0.45	0.50	0.55	-
N	16			2
Nd	4			3
Ne	4			3
θ	0	-	12	4

Rev. 5 2/09

**NOTES:**

1. Dimensioning and tolerancing conform to ASME Y14.5-1994.
2. N is the number of terminals.
3. Nd and Ne refer to the number of terminals on D and E side, respectively.
4. All dimensions are in millimeters. Angles are in degrees.
5. Dimension b applies to the metallized terminal and is measured between 0.15mm and 0.30mm from the terminal tip.
6. The configuration of the pin #1 identifier is optional, but must be located within the zone indicated. The pin #1 identifier may be either a mold or mark feature.
7. Maximum package warpage is 0.05mm.
8. Maximum allowable burrs is 0.076mm in all directions.
9. JEDEC Reference MO-255.
10. For additional information, to assist with the PCB Land Pattern Design effort, see Intersil Technical Brief TB389.

# Package Outline Drawing

## L14.3.5x3.5

### 14 LEAD QUAD FLAT NO-LEAD PLASTIC PACKAGE (QFN)

Rev 0, 2/08

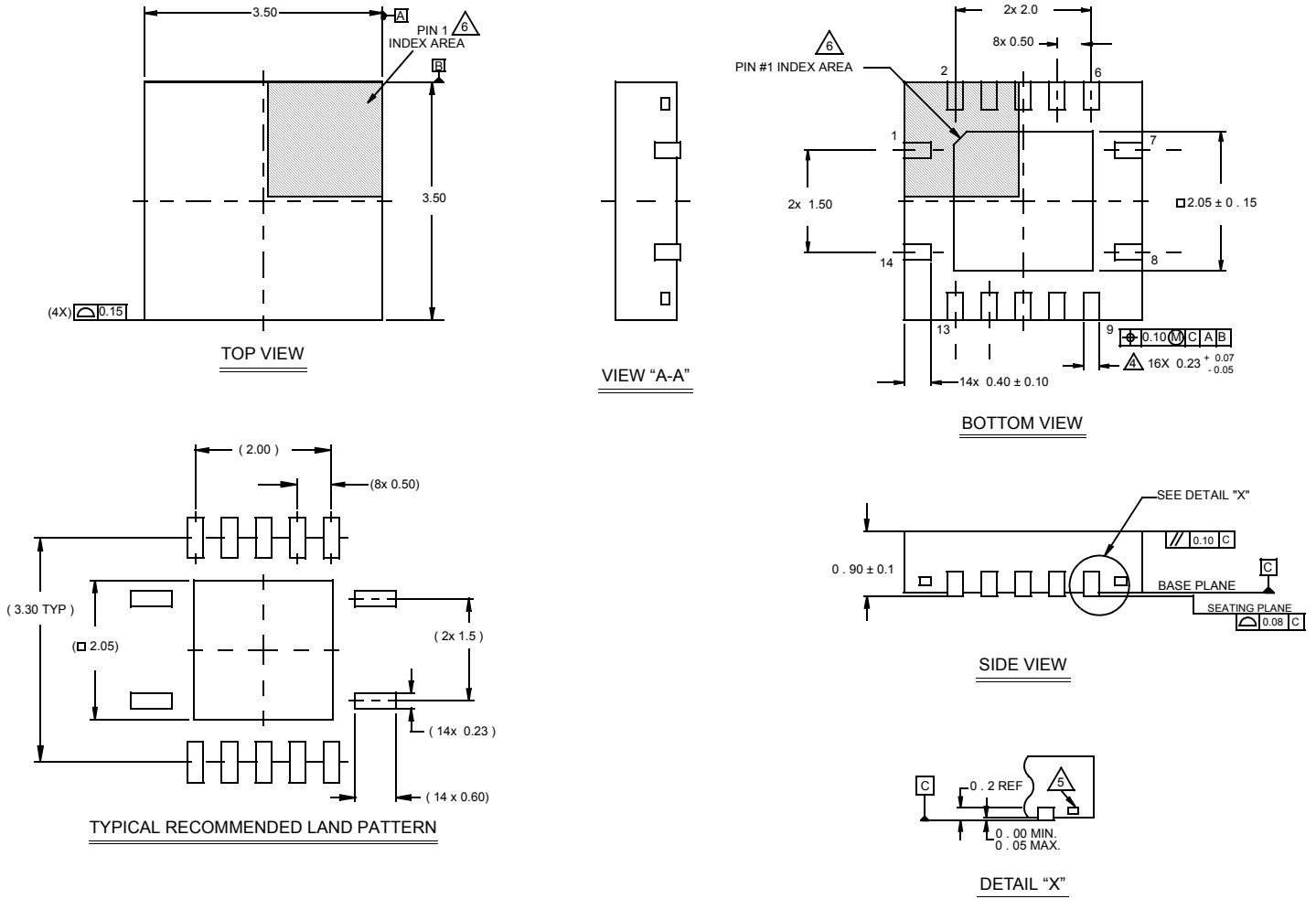

**NOTES:**

1. Dimensions are in millimeters.  
Dimensions in ( ) for Reference Only.
2. Dimensioning and tolerancing conform to AMSE Y14.5m-1994.
3. Unless otherwise specified, tolerance : Decimal ± 0.05
4. Lead width dimension applies to the metallized terminal and is measured between 0.15mm and 0.30mm from the terminal tip.
5. Tiebar shown (if present) is a non-functional feature.
6. The configuration of the pin #1 identifier is optional, but must be located within the zone indicated. The pin #1 identifier may be either a mold or mark feature.

**Thin Quad Flat No-Lead Plastic Package (TQFN)**  
**Thin Micro Lead Frame Plastic Package (TMLFP)**

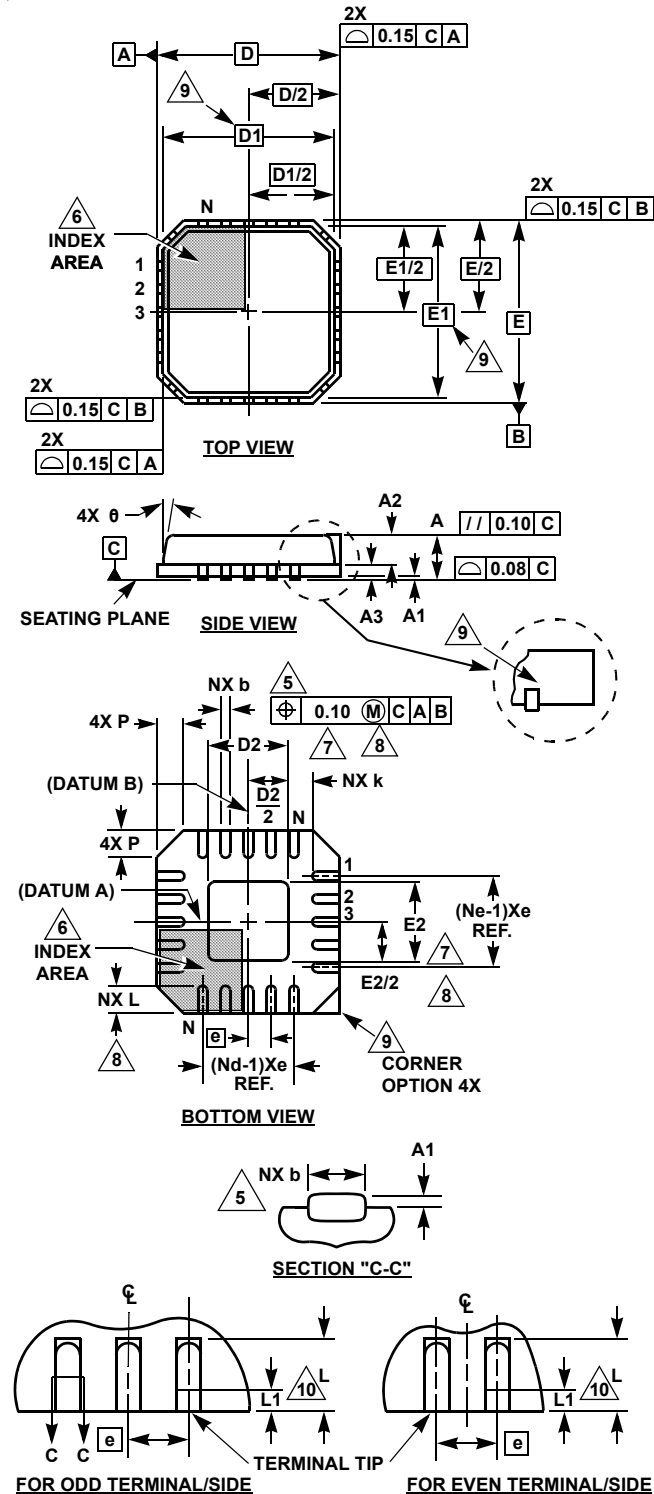

**L16.3x3A**

**16 LEAD THIN QUAD FLAT NO-LEAD PLASTIC PACKAGE**

SYMBOL	MILLIMETERS			NOTES
	MIN	NOMINAL	MAX	
A	0.70	0.75	0.80	-
A1	-	-	0.05	-
A2	-	-	0.80	9
A3	0.20 REF			9
b	0.18	0.23	0.30	5, 8
D	3.00 BSC			-
D1	2.75 BSC			9
D2	1.35	1.50	1.65	7, 8, 10
E	3.00 BSC			-
E1	2.75 BSC			9
E2	1.35	1.50	1.65	7, 8, 10
e	0.50 BSC			-
k	0.20	-	-	-
L	0.30	0.40	0.50	8
N	16			2
Nd	4			3
Ne	4			3
P	-	-	0.60	9
θ	-	-	12	9

Rev. 0 6/04

**NOTES:**

1. Dimensioning and tolerancing conform to ASME Y14.5-1994.
2. N is the number of terminals.
3. Nd and Ne refer to the number of terminals on each D and E.
4. All dimensions are in millimeters. Angles are in degrees.
5. Dimension b applies to the metallized terminal and is measured between 0.15mm and 0.30mm from the terminal tip.
6. The configuration of the pin #1 identifier is optional, but must be located within the zone indicated. The pin #1 identifier may be either a mold or mark feature.
7. Dimensions D2 and E2 are for the exposed pads which provide improved electrical and thermal performance.
8. Nominal dimensions are provided to assist with PCB Land Pattern Design efforts, see Intersil Technical Brief TB389.
9. Features and dimensions A2, A3, D1, E1, P & θ are present when Anvil singulation method is used and not present for saw singulation.
10. Compliant to JEDEC MO-220WEED-2 Issue C, except for the E2 and D2 MAX dimension.



# Mouser Electronics

Authorized Distributor

Click to View Pricing, Inventory, Delivery & Lifecycle Information:

[Renesas Electronics:](#)

[ISL3034EIRTZ](#) [ISL3034EIRTZ-T](#) [ISL3034EIRUZ-T](#)