

**DIMENSIONS FOR LARGE POLARIZATION RIB TERMINAL ONLY**

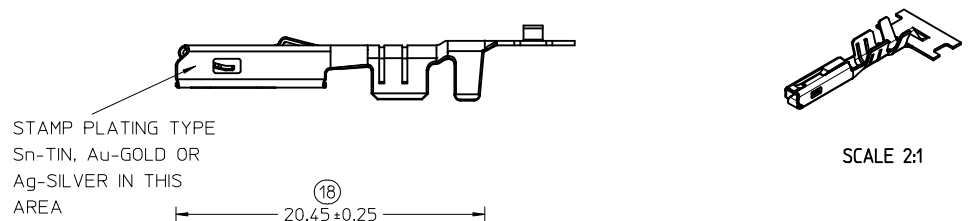

SCALE 2:1

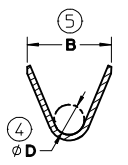
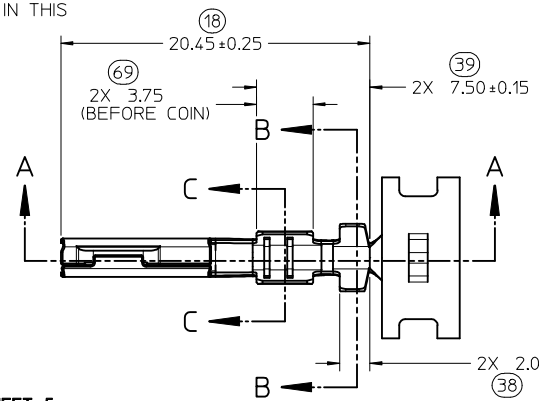

SECTION B-B  
SCALE 5:1

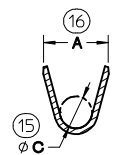

SECTION C-C  
SCALE 5:1

SEE SHEET 5  
FOR M3 GRIP CODE  
TERMINAL

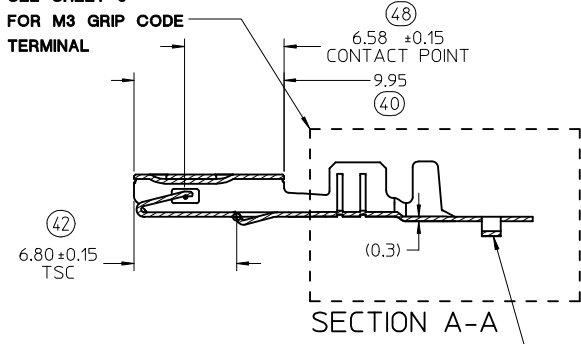

SECTION A-A

CARRIER BUMP DIRECTION  
POINTS DOWN FOR TIN PLATED TERMINALS  
POINTS UP FOR PRECIOUS PLATED TERMINALS

NOTES: (UNLESS OTHERWISE SPECIFIED)

1. MATING TERMINAL SHOWN ON SD-33000-001
2. MATERIAL: ASTM B422, UNS C19025, HR04  
THICKNESS: 0.30 mm +0.01  
TEMPER: FULL HARD (REF)  
TENSILE: 496 MIN MPA
3. TIN PLATED TERMINAL FINISH:  
OVERALL UNDERPLATE ELECTRODEPOSITED NICKEL  
OVERALL ELECTRODEPOSITED REFLOW TIN
4. GOLD PLATED TERMINAL FINISH  
OVERALL UNDERPLATE ELECTRODEPOSITED DUCTILE SULFAMATE NICKEL  
CONTACT AREA - ELECTRODEPOSITED GOLD  
GRIP AREA - ELECTRODEPOSITED 100% TIN MATTE FINISH
5. SILVER PLATED TERMINAL FINISH  
OVERALL UNDERPLATE ELECTRODEPOSITED DUCTILE SULFAMATE NICKEL  
CONTACT AREA - ELECTRODEPOSITED PURE SILVER (0.5% MAX  
IMPURITIES) SEMI-BRIGHT FINISH  
- SILVER ANTI-TARNISH : EVABRITE  
GRIP AREA - ELECTRODEPOSITED 100% TIN MATTE FINISH
6. MEETS PERFORMANCE SPECIFICATION FOR CABLE TO TERMINAL  
ELECTRICAL CRIMPS PER SAE/USCAR-21 (8/2001)
7. MEETS PERFORMANCE STANDARD FOR AUTOMOTIVE ELECTRICAL  
CONNECTOR SYSTEMS FOR SAE/USCAR-2, REV. 4 (TEMP CLASS 3)  
(5/2004)
8. MEETS ELECTRICAL CONNECTION SYSTEM DESIGN SPECIFICATION  
(SDS) REV.11 (5/2002)
9. MEETS FIELD CORRELATED LIFE TEST (FCLT) PER  
SAE/USCAR-20 (6/2004)
10. MEETS WIRING COMPONENT DESIGN GUIDELINES SAE/USCAR-12  
REV 2 (12/2001)
11. TSC ON A DIMENSION TO BE INTERPRETED AS DISTANCE TO  
A THEORETICAL SHARP CORNER AS IF THE RADIUS WERE NOT  
PRESENT
12. REFERENCE 97BG-14474-AAB FOR LARGE POLARIZATION RIB  
CAVITY SPECIFICATION
13. INSERTION FORCE (TIN) AVG. FROM PV TESTING -  
3.8N LARGE POLARIZATION RIB  
3.5N SMALL POLARIZATION RIB  
(REFERENCE)
14. ALL DIMENSIONS EXCEPT (33), (34), (41) & (42) ARE COMMON TO  
BOTH SMALL AND LARGE POLARIZATION RIB TERMINALS
15. REFERENCE PK-31300-516 FOR REEL DIRECTION
16. REFERENCE AS-33012-002 FOR CRIMP INFORMATION

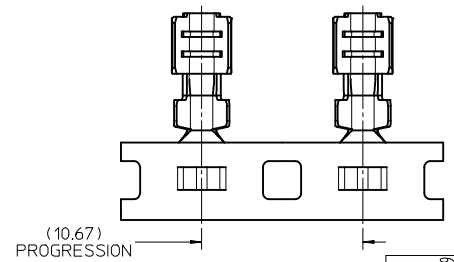
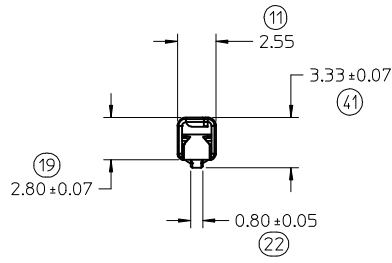

ENTER DESCRIPTION EC NO: UAU2017-1076 DRAWN: KATESH SH 2017/05/29 CHKD: A. DHIR 2017/05/29 APPR: T. J. SMITH 2017/06/09	QUALITY SYMBOLS ▽=0 ▽=0 ▽=0	GENERAL TOLERANCES (UNLESS SPECIFIED)		DIMENSION STYLE MM ONLY		SCALE 4:1	DESIGN UNITS METRIC	THIRD ANGLE PROJECTION	
		mm	INCH	DRAWN BY L. PULLIAM	DATE 2005/06/21	TITLE MX150 RECEPTACLE TERMINAL			
C1	DESCRIPTION REV	4 PLACES	± ---	± ---	CHECKED BY A. DHIR	DATE 2005/06/21	molex DOCUMENT NO. SD-33012-002		
		3 PLACES	± ---	± ---	APPROVED BY B. MOSER	DATE 2005/06/22			
		2 PLACES	± 0.10	± ---			SHEET NO. 1 OF 5		
		1 PLACE	± 0.3	± ---			THIS DRAWING CONTAINS INFORMATION THAT IS PROPRIETARY TO MOLEX INCORPORATED AND SHOULD NOT BE USED WITHOUT WRITTEN PERMISSION		
		0 PLACE	±	±					
		ANGULAR ± 3°		MATERIAL NO.					
		DRAFT WHERE APPLICABLE MUST REMAIN WITHIN DIMENSIONS		SIZE C					

FAMILY	GENDER	SEALING	PLATING	PART NUMBER	PAYOFF DIRECTION	GRIP CODE	WIRE SIZES*	A ±0.30	B ±0.30	C ±0.30	D ±0.30	SPECIAL CHARACTERISTICS
MX150	RECEPTACLE	MAT SEAL	Sn	33012-2001	RIGHT (B)	14	16/14AWG	3.9	4.4	1.7	1.6	HIGH PERFORMANCE Sn
				33012-3001	LEFT (D)		1.50-2.00mm <sup>2</sup>					
				33012-2002	RIGHT (B)	18	20/18AWG	3.3	3.1	1.3	1.4	
				33012-3002	LEFT (D)		0.75-1.00mm <sup>2</sup>					
				33012-2003	RIGHT (B)	22	22AWG	2.5	2.6	0.9	1.0	
				33012-3003	LEFT (D)							
			33012-2004	RIGHT (B)	M3	0.35-0.50mm <sup>2</sup>	2.5	2.7	0.9	1.54 ±0.1		
			33012-3004	LEFT (D)								
			33001-2003	RIGHT (B)	14	16/14AWG	3.9	4.4	1.7	1.6	HIGH PERFORMANCE Au	
			33001-3003	LEFT (D)		1.50-2.00mm <sup>2</sup>						
			33001-2004	RIGHT (B)	18	20/18AWG	3.3	3.1	1.3	1.4		
			33001-3004	LEFT (D)		0.75-1.00mm <sup>2</sup>						
			33001-2005	RIGHT (B)	22	22AWG	2.5	2.6	0.9	1.0		
			33001-3005	LEFT (D)								
			33001-2006	RIGHT (B)	M3	0.35-0.50mm <sup>2</sup>	2.5	2.7	0.9	1.54 ±0.1		
			33001-3006	LEFT (D)								
			33001-4001	RIGHT (B)	14	16/14AWG	3.9	4.4	1.7	1.6	HIGH PERFORMANCE Ag	
			33001-5001	LEFT (D)		1.50-2.00mm <sup>2</sup>						
33001-4002	RIGHT (B)	18	20/18AWG	3.3	3.1	1.3	1.4					
33001-5002	LEFT (D)		0.75-1.00mm <sup>2</sup>									
33001-4003	RIGHT (B)	22	22AWG	2.5	2.6	0.9	1.0					
33001-5003	LEFT (D)											
33001-4005	RIGHT (B)	M3	0.35-0.50mm <sup>2</sup>	2.5	2.7	0.9	1.54 ±0.1					
33001-5005	LEFT (D)											

LARGE POLARIZATION RIB - NOT TO BE USED IN MX150 SEALED CONNECTORS

FAMILY	GENDER	SEALING	PLATING	PART NUMBER	PAYOFF DIRECTION	GRIP CODE	WIRE SIZES*	A ±0.30	B ±0.30	C ±0.30	D ±0.30	SPECIAL CHARACTERISTICS
MX150	RECEPTACLE	UNSEALED	Sn	33012-2021	RIGHT (B)	14	16/14AWG	3.9	4.4	1.7	1.6	HIGH PERFORMANCE Sn
				33012-3021	LEFT (D)		1.50-2.00mm <sup>2</sup>					
				33012-2022	RIGHT (B)	18	20/18AWG	3.3	3.1	1.3	1.4	
				33012-3022	LEFT (D)		0.75-1.00mm <sup>2</sup>					
				33012-2023	RIGHT (B)	22	22AWG	2.5	2.6	0.9	1.0	
				33012-3023	LEFT (D)		0.35-0.50mm <sup>2</sup>					
			33001-2021	RIGHT (B)	14	16/14AWG	3.9	4.4	1.7	1.6	HIGH PERFORMANCE Au	
			33001-3021	LEFT (D)		1.50-2.00mm <sup>2</sup>						
			33001-2022	RIGHT (B)	18	20/18AWG	3.3	3.1	1.3	1.4		
			33001-3022	LEFT (D)		0.75-1.00mm <sup>2</sup>						
			33001-2023	RIGHT (B)	22	22AWG	2.5	2.6	0.9	1.0		
			33001-3023	LEFT (D)		0.35-0.50mm <sup>2</sup>						
			33001-4021	RIGHT (B)	14	16/14AWG	3.9	4.4	1.7	1.6	HIGH PERFORMANCE Ag	
			33001-5021	LEFT (D)		1.50-2.00mm <sup>2</sup>						
			33001-4022	RIGHT (B)	18	20/18AWG	3.3	3.1	1.3	1.4		
			33001-5022	LEFT (D)		0.75-1.00mm <sup>2</sup>						
			33001-4023	RIGHT (B)	22	22AWG	2.5	2.6	0.9	1.0		
			33001-5023	LEFT (D)		0.35-0.50mm <sup>2</sup>						

\* REFERENCE AS-33012-002 FOR SPECIFIC WIRE TYPES

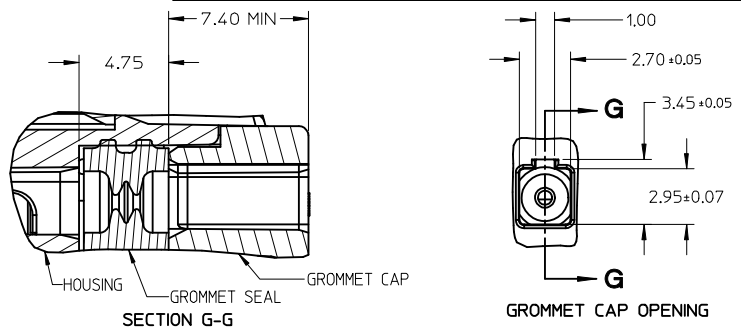

**GROMMET SEAL / CAP CONFIGURATION TO MODIFY LARGE POLARIZATION RIB CAVITY TO ACCEPT SMALL POLARIZATION RIB APPLICATIONS**

<b>ENTER DESCRIPTION</b> EC NO: JAU2017-1076 DRW:WENKATESHSH2017/05/29 CHK:DA. DHIR 2017/05/29 APPR:JSMITH 2017/06/09 REV: C1	QUALITY SYMBOLS ▽=0 ▽=0 ▽=0	GENERAL TOLERANCES (UNLESS SPECIFIED) <table border="1"> <tr> <th></th> <th>mm</th> <th>INCH</th> </tr> <tr> <td>4 PLACES</td> <td>± ---</td> <td>± ---</td> </tr> <tr> <td>3 PLACES</td> <td>± ---</td> <td>± ---</td> </tr> <tr> <td>2 PLACES</td> <td>± 0.10</td> <td>± ---</td> </tr> <tr> <td>1 PLACE</td> <td>± 0.3</td> <td>± ---</td> </tr> <tr> <td>0 PLACE</td> <td>±</td> <td>±</td> </tr> </table>		mm	INCH	4 PLACES	± ---	± ---	3 PLACES	± ---	± ---	2 PLACES	± 0.10	± ---	1 PLACE	± 0.3	± ---	0 PLACE	±	±	DIMENSION STYLE <b>MM ONLY</b> DRAWN BY: L. PULLIAM DATE: 2005/06/21 CHECKED BY: A. DHIR DATE: 2005/06/21 APPROVED BY: B. MOSER DATE: 2005/06/22	SCALE: METRIC DESIGN UNITS: METRIC THIRD ANGLE PROJECTION	TITLE: MX150 RECEPTACLE TERMINAL <b>molex</b> MATERIAL NO. SEE TABLE DOCUMENT NO. SD-33012-002	SHEET NO. 2 OF 5
		mm	INCH																					
	4 PLACES	± ---	± ---																					
	3 PLACES	± ---	± ---																					
	2 PLACES	± 0.10	± ---																					
1 PLACE	± 0.3	± ---																						
0 PLACE	±	±																						
DRAFT WHERE APPLICABLE MUST REMAIN WITHIN DIMENSIONS		ANGULAR ± 3 °	THIS DRAWING CONTAINS INFORMATION THAT IS PROPRIETARY TO MOLEX INCORPORATED AND SHOULD NOT BE USED WITHOUT WRITTEN PERMISSION																					

THIS CHECKING - AID IS FOR SMALL POLARIZATION RIB TERMINALS ONLY

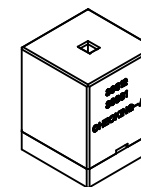

CHECKING - AID ASSEMBLY  
SCALE 1:1

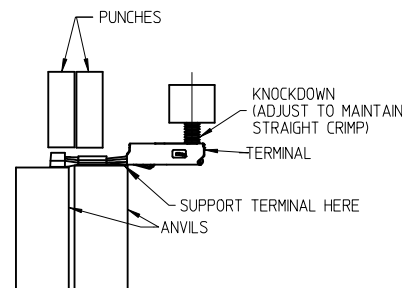
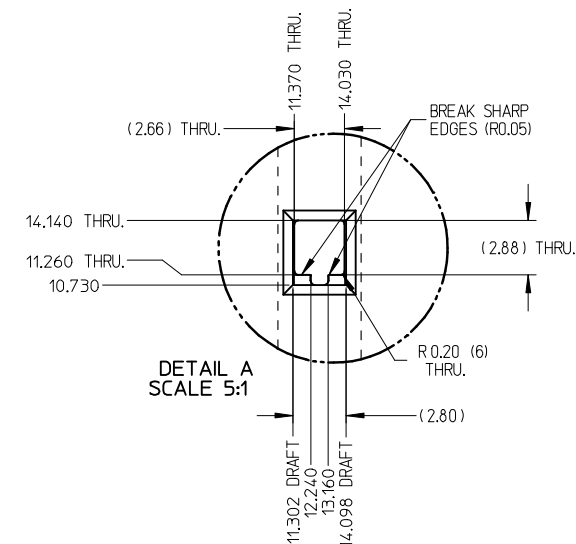
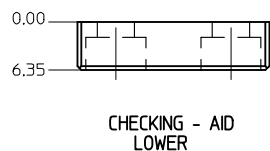
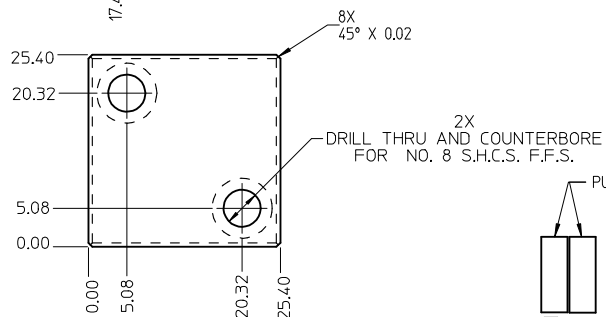
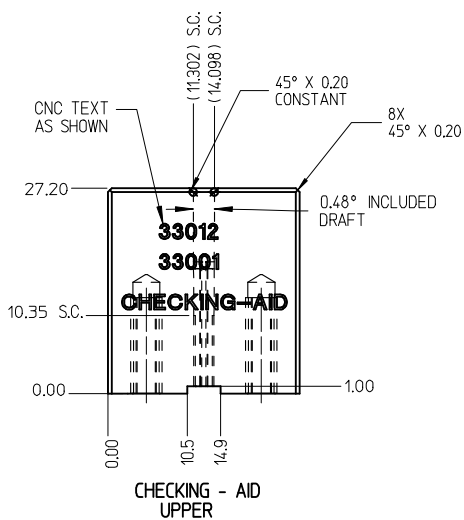
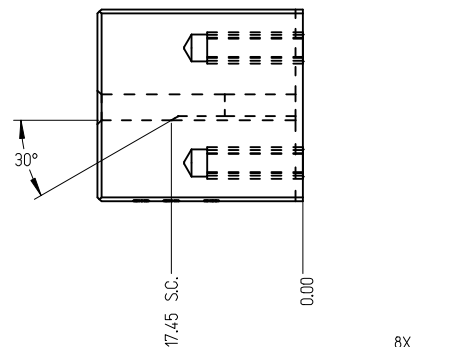
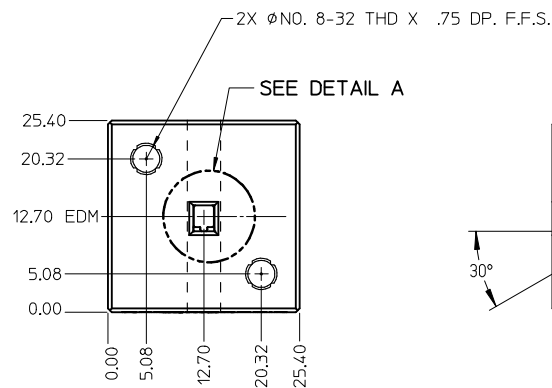

CRIMP REQUIREMENTS:

1. CRIMP STRAIGHTNESS MUST BE MAINTAINED USE A KNOCKDOWN TOOL LOCATED AS SHOWN TERMINAL BOX MUST NOT BE DEFORMED
2. AFTER CRIMPING, THE CRIMPED TERMINAL (AND UP TO 5 mm OF WIRE PAST THE INSULATOR CUTOFF TAB) MUST FIT FREELY INTO THE CHECKING-AID SHOWN ON THIS PAGE
3. FOR OTHER MECHANICAL REQUIREMENTS ON CRIMPED TERMINALS, REFER TO SAE/USCAR-21 (5-13-02) SECTIONS 4.2 (VISUAL INSPECTION), 4.2 (CROSS SECTION ANALYSIS) AND 4.4 (CONDUCTOR CRIMP PULLOUT FORCE)

UPPER & LOWER  
CHECKING-AID  
A2 TOOL STEEL  
HARDEN & GRIND  
ROCKWELL "C" 56-58

<b>ENTER DESCRIPTION</b> EC NO: UAU2017-1076 DRWN:WENKATESHSH2017/05/29 CHKD:A. DHIR 2017/05/29 APPR:T.JSMITH 2017/06/09	<b>QUALITY SYMBOLS</b> 	<b>GENERAL TOLERANCES (UNLESS SPECIFIED)</b>		DIMENSION STYLE <b>MM ONLY</b>	SCALE <b>2:1</b>	DESIGN UNITS <b>METRIC</b>	THIRD ANGLE PROJECTION
		4 PLACES ± --- ± --- 3 PLACES ± --- ± --- 2 PLACES ± 0.10 ± --- 1 PLACE ± 0.3 ± --- 0 PLACE ± ±	mm INCH	DRAWN BY DATE L. PULLIAM 2005/06/21	CHECKED BY DATE A. DHIR 2005/06/21	MX150 RECEPTACLE TERMINAL  <b>molex</b> DOCUMENT NO. SD-33012-002 SHEET NO. 3 OF 5	
ANGULAR ± 3° DRAFT WHERE APPLICABLE MUST REMAIN WITHIN DIMENSIONS	MATERIAL NO. <b>SEE TABLE</b>	APPROVED BY DATE B. MOSER 2005/06/22		THIS DRAWING CONTAINS INFORMATION THAT IS PROPRIETARY TO MOLEX. INCORPORATED AND SHOULD NOT BE USED WITHOUT WRITTEN PERMISSION			

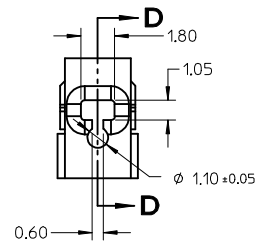
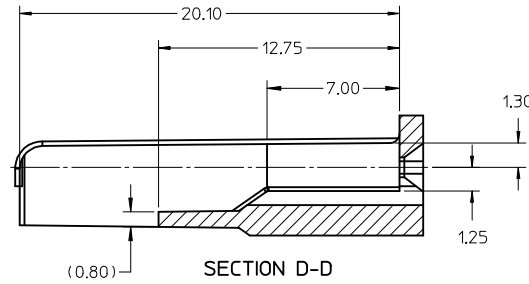
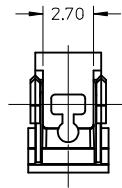

NOTES: UNLESS OTHERWISE SPECIFIED

1. TOLERANCES: LINEAR  $\pm 0.10$   
ANGULAR  $\pm 3^\circ$
2. ALL DRAFT WITHIN TOLERANCE.
3. MAX RADII ON ALL CORNERS SHOWN SHARP: 0.10
4. MAX FLASH PERMISSIBLE: 0.1
5. EJECTOR PIN MARKS PERMISSIBLE IF FLUSH TO 0.25 BELOW SURFACE.
6. MATERIAL: HOUSING/FINGER SPECIFICATION ENGINEERED FOR MATERIAL WITH THE FOLLOWING PROPERTIES:  
A. FLEXURAL MODULUS = 4,500 TO 9,400 MPa  
PER ASTM TEST D790  
B. ELONGATION AT YIELD = 2.3% OR BETTER  
PER ASTM TEST D638 TYPE V
7. CAVITY SPEC FOR USE ONLY WITH MOLEX RECEPTACLE  
TERMINAL PART NUMBERS SPECIFIED ELSEWHERE ON THIS  
DRAWING

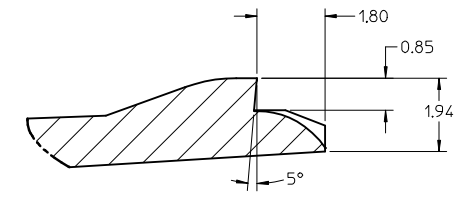
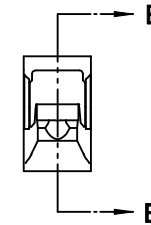
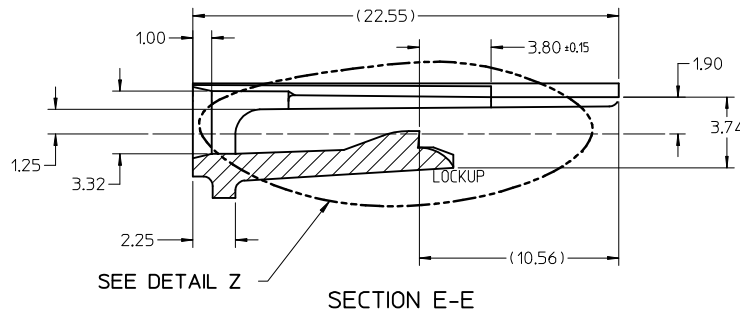
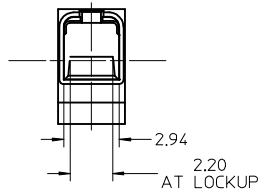

DETAIL Z  
SCALE 20:1

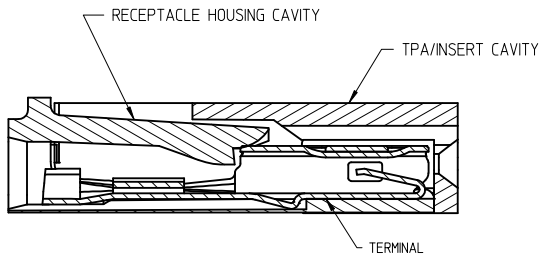

SECTION F-F

RECEPTACLE CAVITY ASSEMBLED VIEWS  
FOR SMALL POLARIZATION RIB APPLICATIONS  
FIG. 1

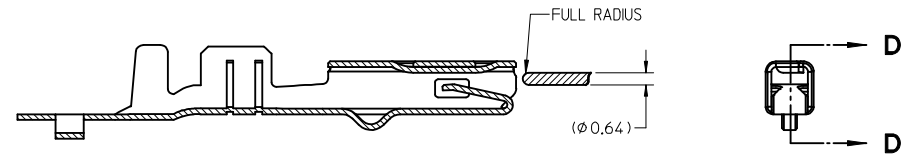
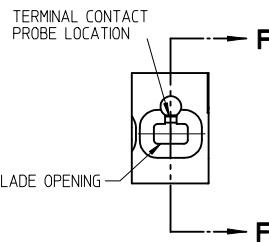

SECTION D-D  
FOR LARGE POLARIZATION RIB APPLICATIONS  
FIG. 2

PROBING DOWN THE  
THROAT MUST USE  
THIS TERMINAL PROBE

FOR PROBING INFORMATION REFERENCE  
MOLEX MX150 APPLICATION SPEC AS-33472-100

PREFERRED PROBING LOCATION  
IS NOT ON SPRING MEMBER

IF ELECTRICAL CONTINUITY PROBE  
TOUCHES SPRING MEMBER USE  
PROBING AS SHOWN IN FIG. 2

ENTER DESCRIPTION EC NO: UAU2017-1076 DRAWN: VENKATESHSH/2017/05/29 CHKD: A. DHIR 2017/05/29 APPR: T.JSMITH 2017/06/09	QUALITY SYMBOLS ▽=0 ▽=0 ▽=0	GENERAL TOLERANCES (UNLESS SPECIFIED)		DIMENSION STYLE MM ONLY		SCALE 5:1	DESIGN UNITS METRIC	THIRD ANGLE PROJECTION	
		4 PLACES ± --- ± ---	3 PLACES ± --- ± ---	2 PLACES ± 0.10 ± ---	1 PLACE ± 0.3 ± ---	0 PLACE ± ±	DRAWN BY DATE L. PULLIAM 2005/06/21		CHECKED BY DATE A. DHIR 2005/06/21
C1	DESCRIPTION	ANGULAR ± 3°		MATERIAL NO.		DOCUMENT NO.		SHEET NO.	
		DRAFT WHERE APPLICABLE MUST REMAIN WITHIN DIMENSIONS		SEE TABLE		SD-33012-002		4 OF 5	
THIS DRAWING CONTAINS INFORMATION THAT IS PROPRIETARY TO MOLEX INCORPORATED AND SHOULD NOT BE USED WITHOUT WRITTEN PERMISSION									

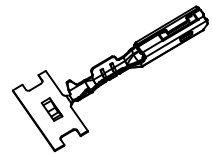

ISO VIEW  
SCALE 2:1

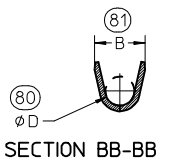
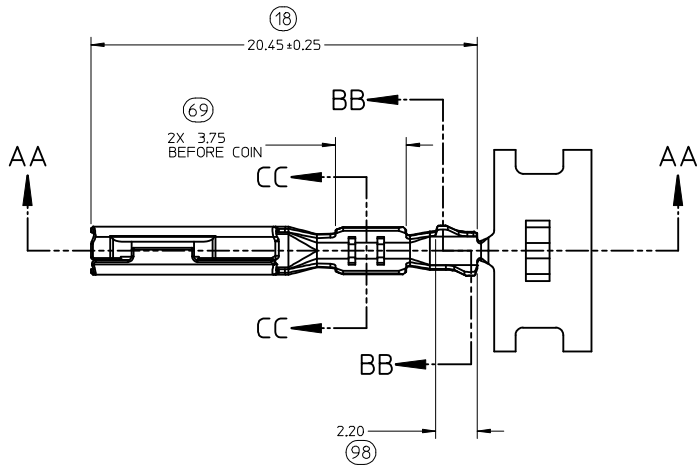

SECTION BB-BB

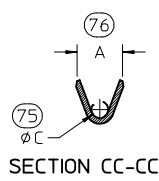

SECTION CC-CC

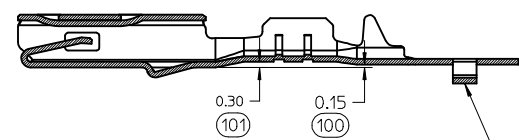
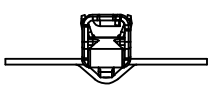

SECTION AA-AA  
**M3 GRIP CODE TERMINAL**  
SEE TABLE (SHEET 2) FOR PART NUMBERS

CARRIER BUMP DIRECTION  
POINTS DOWN FOR TIN PLATED TERMINAL  
POINTS UP FOR PRECIOUS METAL PLATED TERMINAL

<b>ENTER DESCRIPTION</b> EC NO: UAU2017-1076 DRW: N VENKATESH 2017/05/29 CHKD: A. DHIR 2017/05/29 APPR: T. SMITH 2017/06/09	QUALITY SYMBOLS ▽=0 ▽=0 ▽=0	GENERAL TOLERANCES (UNLESS SPECIFIED)		DIMENSION STYLE <b>MM ONLY</b>	SCALE <b>5:1</b>	DESIGN UNITS <b>METRIC</b>	THIRD ANGLE PROJECTION	
		4 PLACES ± --- ± --- 3 PLACES ± --- ± --- 2 PLACES ± 0.10 ± --- 1 PLACE ± 0.3 ± ---	mm INCH	DRAWN BY DATE L. PULLIAM 2005/06/21	TITLE <b>MX150 RECEPTACLE TERMINAL</b>			
		ANGULAR ± 3°		CHECKED BY DATE A. DHIR 2005/06/21	MOLEX INCORPORATED			
		DRAFT WHERE APPLICABLE MUST REMAIN WITHIN DIMENSIONS		APPROVED BY DATE B. MOSER 2005/06/22	MATERIAL NO. <b>SEE TABLE</b>	DOCUMENT NO. <b>SD-33012-002</b>	SHEET NO. <b>5 OF 5</b>	

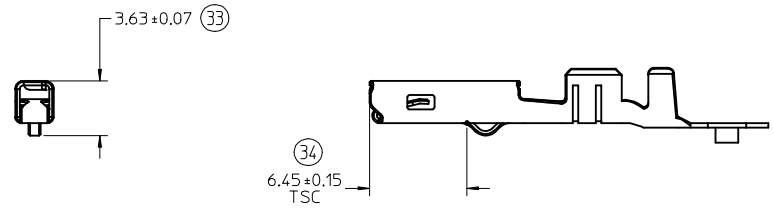

**DIMENSIONS FOR LARGE POLARIZATION RIB TERMINAL ONLY**

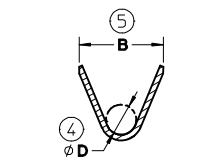
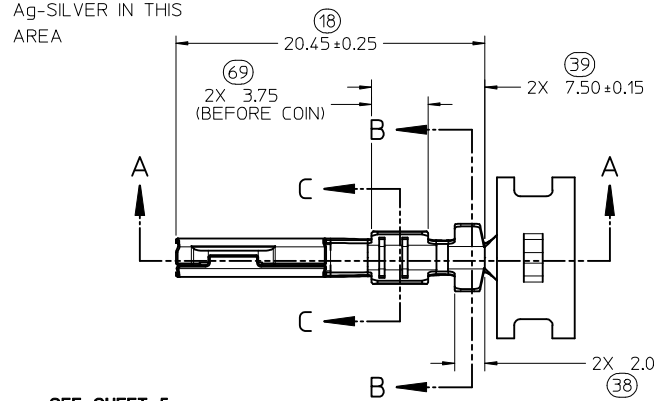
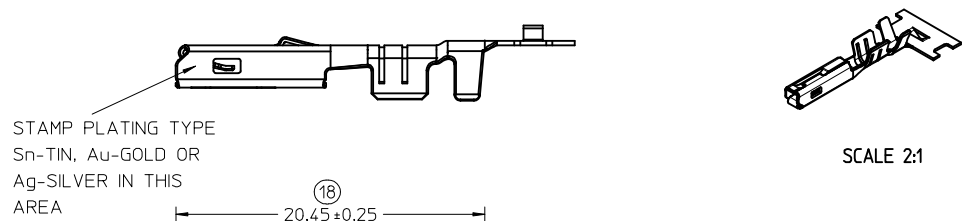

**SECTION B-B  
SCALE 5:1**

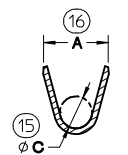

**SECTION C-C  
SCALE 5:1**

NOTES: (UNLESS OTHERWISE SPECIFIED)

1. MATING TERMINAL SHOWN ON SD-33000-001
2. MATERIAL: ASTM B422, UNS C19025, HR04  
THICKNESS: 0.30 mm +0.01  
TEMPER: FULL HARD (REF)  
TENSILE: 496 MIN MPA
3. TIN PLATED TERMINAL FINISH:  
OVERALL UNDERPLATE ELECTRODEPOSITED NICKEL  
OVERALL ELECTRODEPOSITED REFLOW TIN
4. GOLD PLATED TERMINAL FINISH:  
OVERALL UNDERPLATE ELECTRODEPOSITED DUCTILE SULFAMATE NICKEL  
CONTACT AREA - ELECTRODEPOSITED GOLD  
GRIP AREA - ELECTRODEPOSITED 100% TIN MATTE FINISH
5. SILVER PLATED TERMINAL FINISH:  
OVERALL UNDERPLATE ELECTRODEPOSITED DUCTILE SULFAMATE NICKEL  
CONTACT AREA - ELECTRODEPOSITED PURE SILVER (0.5% MAX IMPURITIES) SEMI-BRIGHT FINISH  
- SILVER ANTI-TARNISH : EVABRITE  
GRIP AREA - ELECTRODEPOSITED 100% TIN MATTE FINISH
6. MEETS PERFORMANCE SPECIFICATION FOR CABLE TO TERMINAL ELECTRICAL CRIMPS PER SAE/USCAR-21 (8/2001)
7. MEETS PERFORMANCE STANDARD FOR AUTOMOTIVE ELECTRICAL CONNECTOR SYSTEMS FOR SAE/USCAR-2, REV. 4 (TEMP CLASS 3) (5/2004)
8. MEETS ELECTRICAL CONNECTION SYSTEM DESIGN SPECIFICATION (SDS) REV.11 (5/2002)
9. MEETS FIELD CORRELATED LIFE TEST (FCLT) PER SAE/USCAR-20 (6/2004)
10. MEETS WIRING COMPONENT DESIGN GUIDELINES SAE/USCAR-12 REV 2 (12/2001)
11. TSC ON A DIMENSION TO BE INTERPRETED AS DISTANCE TO A THEORETICAL SHARP CORNER AS IF THE RADIUS WERE NOT PRESENT
12. REFERENCE 97BG-14474-AAB FOR LARGE POLARIZATION RIB CAVITY SPECIFICATION
13. INSERTION FORCE (TINI) AVG. FROM PV TESTING -  
3.8N LARGE POLARIZATION RIB  
3.5N SMALL POLARIZATION RIB (REFERENCE)
14. ALL DIMENSIONS EXCEPT (33), (34), (41) & (42) ARE COMMON TO BOTH SMALL AND LARGE POLARIZATION RIB TERMINALS
15. REFERENCE PK-31300-516 FOR REEL DIRECTION
16. REFERENCE AS-33012-002 FOR CRIMP INFORMATION

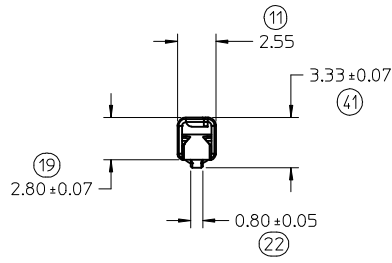

**SEE SHEET 5  
FOR M3 GRIP CODE  
TERMINAL**

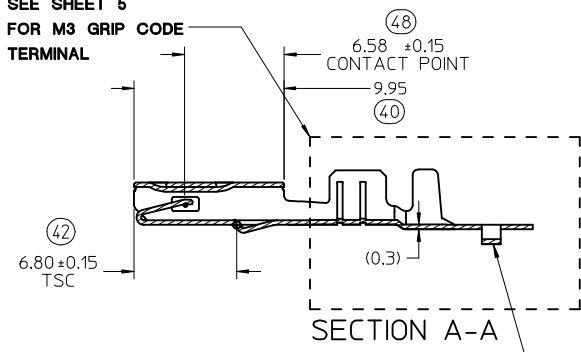

CARRIER BUMP DIRECTION  
POINTS DOWN FOR TIN PLATED TERMINALS  
POINTS UP FOR PRECIOUS PLATED TERMINALS

(10.67)  
PROGRESSION

<b>ENTER DESCRIPTION</b> EC NO: UAU2017-1076 DRW: NANKATESHSH/2017/05/29 CHK: D.A., DHIR 2017/05/29 APPR: T.JSM/TH 2017/06/09	QUALITY SYMBOLS ∇=0 ∇=0 ∇=0	GENERAL TOLERANCES (UNLESS SPECIFIED)		DIMENSION STYLE <b>MM ONLY</b>		SCALE 4:1	DESIGN UNITS METRIC	THIRD ANGLE PROJECTION	
		4 PLACES ± --- ± --- 3 PLACES ± --- ± --- 2 PLACES ± 0.10 ± --- 1 PLACE ± 0.3 ± --- 0 PLACE ± ±	mm INCH	DRAWN BY DATE L. PULLIAM 2005/06/21	CHECKED BY DATE A. DHIR 2005/06/21	APPROVED BY DATE B. MOSER 2005/06/22		TITLE <b>MX150 RECEPTACLE TERMINAL</b>	
DRAFT WHERE APPLICABLE MUST REMAIN WITHIN DIMENSIONS		ANGULAR ± 3 °		MATERIAL NO. <b>SEE TABLE</b>		DOCUMENT NO. <b>SD-33012-002</b>		SHEET NO. 1 OF 5	
THIS DRAWING CONTAINS INFORMATION THAT IS PROPRIETARY TO MOLEX INCORPORATED AND SHOULD NOT BE USED WITHOUT WRITTEN PERMISSION									

FAMILY	GENDER	SEALING	PLATING	PART NUMBER	PAYOFF DIRECTION	GRIP CODE	WIRE SIZES*	A ±0.30	B ±0.30	C ±0.30	D ±0.30	SPECIAL CHARACTERISTICS
MX150	RECEPTACLE	MAT SEAL	Sn	33012-2001	RIGHT (B)	14	16/14AWG	3.9	4.4	1.7	1.6	HIGH PERFORMANCE Sn
				33012-3001	LEFT (D)		1.50-2.00mm <sup>2</sup>					
				33012-2002	RIGHT (B)	18	20/18AWG	3.3	3.1	1.3	1.4	
				33012-3002	LEFT (D)		0.75-1.00mm <sup>2</sup>					
				33012-2003	RIGHT (B)	22	22AWG	2.5	2.6	0.9	1.0	
				33012-3003	LEFT (D)							
			33012-2004	RIGHT (B)	M3	0.35-0.50mm <sup>2</sup>	2.5	2.7	0.9	1.54 ±0.1		
			33012-3004	LEFT (D)								
			33001-2003	RIGHT (B)	14	16/14AWG	3.9	4.4	1.7	1.6	HIGH PERFORMANCE Au	
			33001-3003	LEFT (D)		1.50-2.00mm <sup>2</sup>						
			33001-2004	RIGHT (B)	18	20/18AWG	3.3	3.1	1.3	1.4		
			33001-3004	LEFT (D)		0.75-1.00mm <sup>2</sup>						
			33001-2005	RIGHT (B)	22	22AWG	2.5	2.6	0.9	1.0		
			33001-3005	LEFT (D)								
			33001-2006	RIGHT (B)	M3	0.35-0.50mm <sup>2</sup>	2.5	2.7	0.9	1.54 ±0.1		
			33001-3006	LEFT (D)								
			33001-4001	RIGHT (B)	14	16/14AWG	3.9	4.4	1.7	1.6	HIGH PERFORMANCE Ag	
			33001-5001	LEFT (D)		1.50-2.00mm <sup>2</sup>						
33001-4002	RIGHT (B)	18	20/18AWG	3.3	3.1	1.3	1.4					
33001-5002	LEFT (D)		0.75-1.00mm <sup>2</sup>									
33001-4003	RIGHT (B)	22	22AWG	2.5	2.6	0.9	1.0					
33001-5003	LEFT (D)											
33001-4005	RIGHT (B)	M3	0.35-0.50mm <sup>2</sup>	2.5	2.7	0.9	1.54 ±0.1					
33001-5005	LEFT (D)											

LARGE POLARIZATION RIB - NOT TO BE USED IN MX150 SEALED CONNECTORS

FAMILY	GENDER	SEALING	PLATING	PART NUMBER	PAYOFF DIRECTION	GRIP CODE	WIRE SIZES*	A ±0.30	B ±0.30	C ±0.30	D ±0.30	SPECIAL CHARACTERISTICS
MX150	RECEPTACLE	UNSEALED	Sn	33012-2021	RIGHT (B)	14	16/14AWG	3.9	4.4	1.7	1.6	HIGH PERFORMANCE Sn
				33012-3021	LEFT (D)		1.50-2.00mm <sup>2</sup>					
				33012-2022	RIGHT (B)	18	20/18AWG	3.3	3.1	1.3	1.4	
				33012-3022	LEFT (D)		0.75-1.00mm <sup>2</sup>					
				33012-2023	RIGHT (B)	22	22AWG	2.5	2.6	0.9	1.0	
				33012-3023	LEFT (D)		0.35-0.50mm <sup>2</sup>					
			33001-2021	RIGHT (B)	14	16/14AWG	3.9	4.4	1.7	1.6	HIGH PERFORMANCE Au	
			33001-3021	LEFT (D)		1.50-2.00mm <sup>2</sup>						
			33001-2022	RIGHT (B)	18	20/18AWG	3.3	3.1	1.3	1.4		
			33001-3022	LEFT (D)		0.75-1.00mm <sup>2</sup>						
			33001-2023	RIGHT (B)	22	22AWG	2.5	2.6	0.9	1.0		
			33001-3023	LEFT (D)		0.35-0.50mm <sup>2</sup>						
			33001-4021	RIGHT (B)	14	16/14AWG	3.9	4.4	1.7	1.6	HIGH PERFORMANCE Ag	
			33001-5021	LEFT (D)		1.50-2.00mm <sup>2</sup>						
			33001-4022	RIGHT (B)	18	20/18AWG	3.3	3.1	1.3	1.4		
			33001-5022	LEFT (D)		0.75-1.00mm <sup>2</sup>						
			33001-4023	RIGHT (B)	22	22AWG	2.5	2.6	0.9	1.0		
			33001-5023	LEFT (D)		0.35-0.50mm <sup>2</sup>						

\* REFERENCE AS-33012-002 FOR SPECIFIC WIRE TYPES

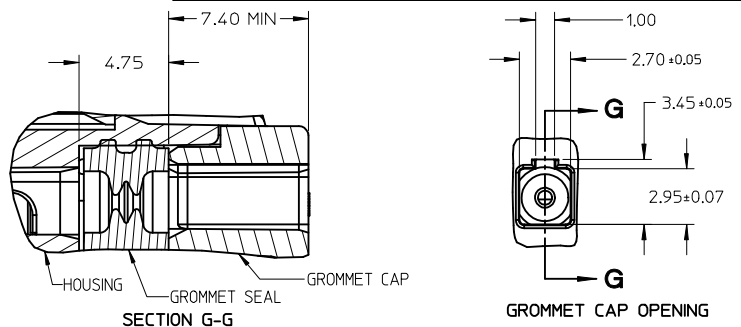

**GROMMET SEAL / CAP CONFIGURATION TO MODIFY LARGE POLARIZATION RIB CAVITY TO ACCEPT SMALL POLARIZATION RIB APPLICATIONS**

<b>ENTER DESCRIPTION</b> EC NO: JAU2017-1076 DRW:WENKATESHSH2017/05/29 CHK:DA. DHIR 2017/05/29 APPR:JSMITH 2017/06/09	QUALITY SYMBOLS ▽=0 ▽=0 ▽=0	GENERAL TOLERANCES (UNLESS SPECIFIED)		DIMENSION STYLE <b>MM ONLY</b>		SCALE	DESIGN UNITS METRIC	THIRD ANGLE PROJECTION		
		4 PLACES ± --- ± --- 3 PLACES ± --- ± --- 2 PLACES ± 0.10 ± --- 1 PLACE ± 0.3 ± --- 0 PLACE ± ±	mm INCH --- --- --- --- --- --- --- --- --- ---	DRAWN BY L. PULLIAM	DATE 2005/06/21	TITLE MX150 RECEPTACLE TERMINAL				
		APPROVED BY B. MOSER		DATE 2005/06/22		MATERIAL NO. <b>SEE TABLE</b>		DOCUMENT NO. SD-33012-002	SHEET NO. 2 OF 5	
		DRAFT WHERE APPLICABLE MUST REMAIN WITHIN DIMENSIONS				THIS DRAWING CONTAINS INFORMATION THAT IS PROPRIETARY TO MOLEX INCORPORATED AND SHOULD NOT BE USED WITHOUT WRITTEN PERMISSION				

THIS CHECKING - AID IS FOR SMALL POLARIZATION RIB TERMINALS ONLY

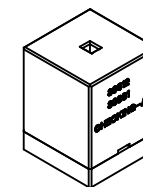

CHECKING - AID ASSEMBLY  
SCALE 1:1

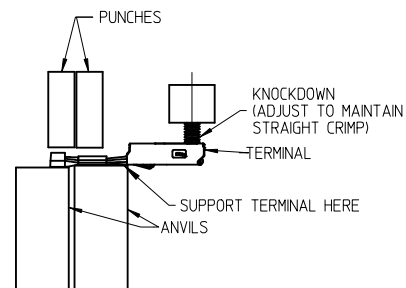
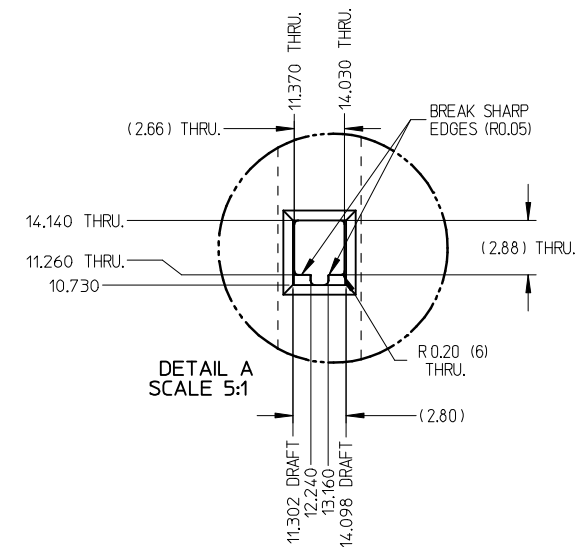
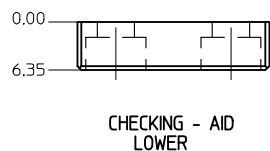
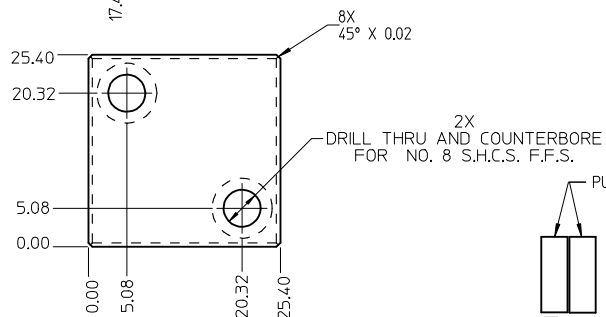
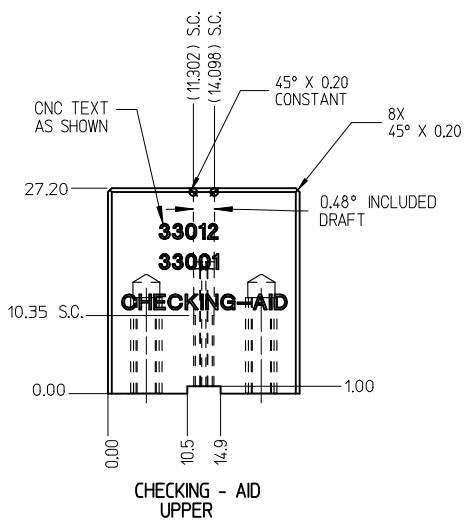
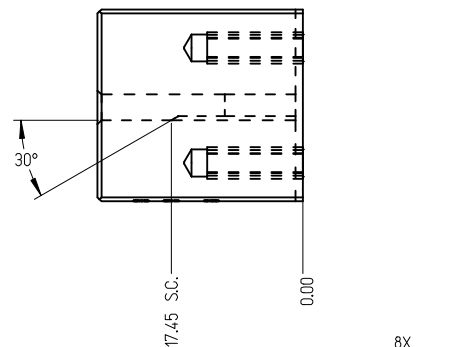
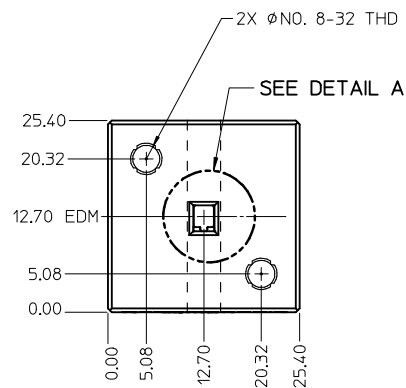

CRIMP REQUIREMENTS:

1. CRIMP STRAIGHTNESS MUST BE MAINTAINED USE A KNOCKDOWN TOOL LOCATED AS SHOWN TERMINAL BOX MUST NOT BE DEFORMED
2. AFTER CRIMPING, THE CRIMPED TERMINAL (AND UP TO 5 mm OF WIRE PAST THE INSULATOR CUTOFF TAB) MUST FIT FREELY INTO THE CHECKING-AID SHOWN ON THIS PAGE
3. FOR OTHER MECHANICAL REQUIREMENTS ON CRIMPED TERMINALS, REFER TO SAE/USCAR-21 (5-13-02) SECTIONS 4.2 (VISUAL INSPECTION), 4.2 (CROSS SECTION ANALYSIS) AND 4.4 (CONDUCTOR CRIMP PULLOUT FORCE)

UPPER & LOWER  
CHECKING-AID  
A2 TOOL STEEL  
HARDEN & GRIND  
ROCKWELL "C" 56-58

<b>ENTER DESCRIPTION</b> EC NO: UAU2017-1076 DRWN:WENKATESHSH2017/05/29 CHKD:A. DHIR 2017/05/29 APPR:T.JSMITH 2017/06/09	<b>QUALITY SYMBOLS</b> 	<b>GENERAL TOLERANCES (UNLESS SPECIFIED)</b>		DIMENSION STYLE <b>MM ONLY</b>	SCALE <b>2:1</b>	DESIGN UNITS <b>METRIC</b>	THIRD ANGLE PROJECTION
		4 PLACES ± --- ± --- 3 PLACES ± --- ± --- 2 PLACES ± 0.10 ± --- 1 PLACE ± 0.3 ± --- 0 PLACE ± ±	mm INCH	DRAWN BY DATE L. PULLIAM 2005/06/21	CHECKED BY DATE A. DHIR 2005/06/21	MX150 RECEPTACLE TERMINAL	
<b>DESCRIPTION</b> C1	<b>REVISION</b>	ANGULAR ± 3°		MATERIAL NO. <b>SEE TABLE</b>	DOCUMENT NO. <b>SD-33012-002</b>	SHEET NO. <b>3 OF 5</b>	
		DRAFT WHERE APPLICABLE MUST REMAIN WITHIN DIMENSIONS		THIS DRAWING CONTAINS INFORMATION THAT IS PROPRIETARY TO MOLEX. INCORPORATED AND SHOULD NOT BE USED WITHOUT WRITTEN PERMISSION			



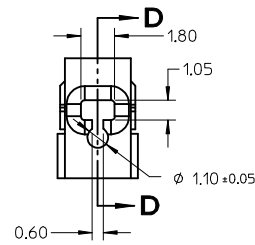
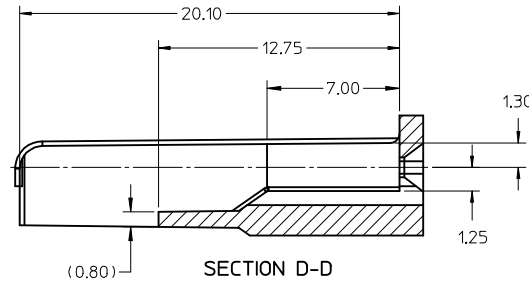
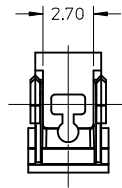

NOTES: UNLESS OTHERWISE SPECIFIED

1. TOLERANCES: LINEAR  $\pm 0.10$   
ANGULAR  $\pm 3^\circ$
2. ALL DRAFT WITHIN TOLERANCE.
3. MAX RADII ON ALL CORNERS SHOWN SHARP: 0.10
4. MAX FLASH PERMISSIBLE: 0.1
5. EJECTOR PIN MARKS PERMISSIBLE IF FLUSH TO 0.25 BELOW SURFACE.
6. MATERIAL: HOUSING/FINGER SPECIFICATION ENGINEERED FOR MATERIAL WITH THE FOLLOWING PROPERTIES:  
A. FLEXURAL MODULUS = 4,500 TO 9,400 MPa  
PER ASTM TEST D790  
B. ELONGATION AT YIELD = 2.3% OR BETTER  
PER ASTM TEST D638 TYPE V
7. CAVITY SPEC FOR USE ONLY WITH MOLEX RECEPTACLE  
TERMINAL PART NUMBERS SPECIFIED ELSEWHERE ON THIS  
DRAWING

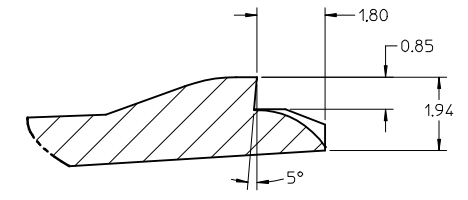
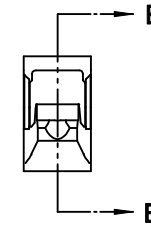
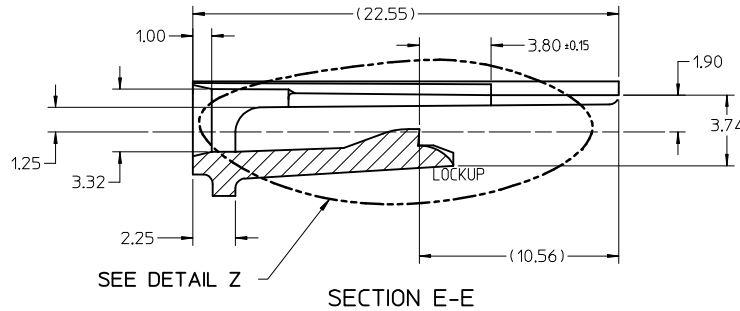
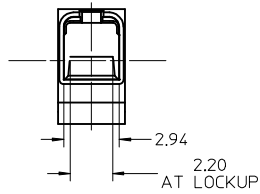

DETAIL Z  
SCALE 20:1

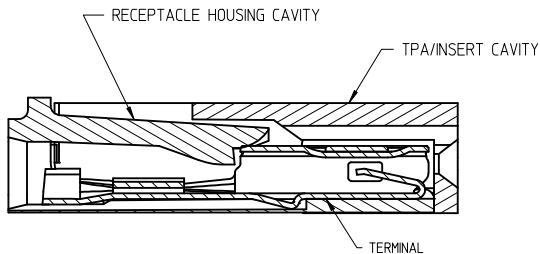

SECTION F-F

RECEPTACLE CAVITY ASSEMBLED VIEWS  
FOR SMALL POLARIZATION RIB APPLICATIONS  
FIG. 1

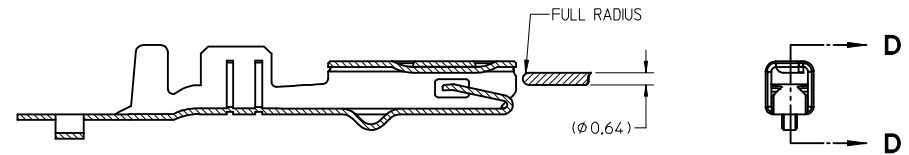
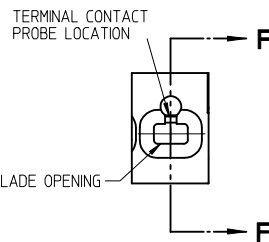

SECTION D-D  
FOR LARGE POLARIZATION RIB APPLICATIONS  
FIG. 2

PROBING DOWN THE  
THROAT MUST USE  
THIS TERMINAL PROBE

FOR PROBING INFORMATION REFERENCE  
MOLEX MX150 APPLICATION SPEC AS-33472-100

PREFERRED PROBING LOCATION  
IS NOT ON SPRING MEMBER

IF ELECTRICAL CONTINUITY PROBE  
TOUCHES SPRING MEMBER USE  
PROBING AS SHOWN IN FIG. 2

ENTER DESCRIPTION EC NO: UAU2017-1076 DRAWN: VENKATESHSH/2017/05/29 CHKD: A. DHIR 2017/05/29 APPR: T.JSMITH 2017/06/09	QUALITY SYMBOLS ▽=0 ▽=0 ▽=0	GENERAL TOLERANCES (UNLESS SPECIFIED)		DIMENSION STYLE MM ONLY		SCALE 5:1	DESIGN UNITS METRIC	THIRD ANGLE PROJECTION	
		4 PLACES ± --- ± ---	3 PLACES ± --- ± ---	2 PLACES ± 0.10 ± ---	1 PLACE ± 0.3 ± ---	0 PLACE ± ±	DRAWN BY DATE L. PULLIAM 2005/06/21		CHECKED BY DATE A. DHIR 2005/06/21
C1	DESCRIPTION REV	ANGULAR ± 3°		MATERIAL NO.		DOCUMENT NO.		SHEET NO.	
		DRAFT WHERE APPLICABLE MUST REMAIN WITHIN DIMENSIONS		SEE TABLE		SD-33012-002		4 OF 5	
THIS DRAWING CONTAINS INFORMATION THAT IS PROPRIETARY TO MOLEX INCORPORATED AND SHOULD NOT BE USED WITHOUT WRITTEN PERMISSION									

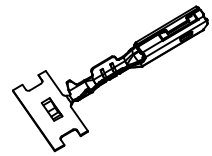

ISO VIEW  
SCALE 2:1

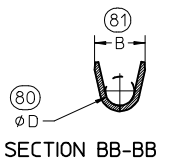
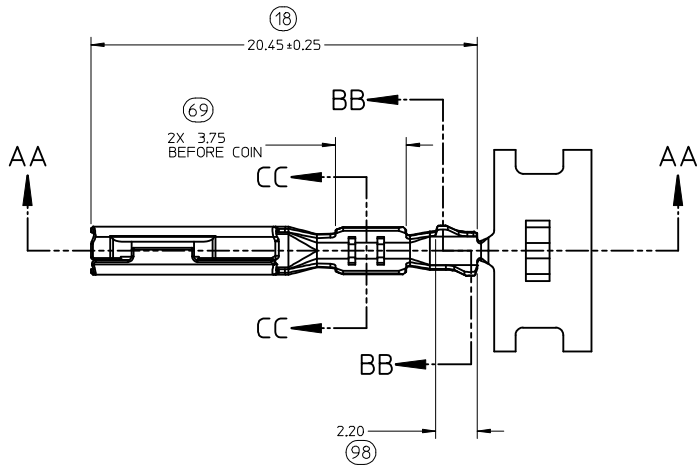

SECTION BB-BB

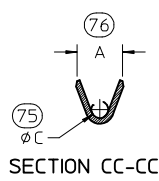

SECTION CC-CC

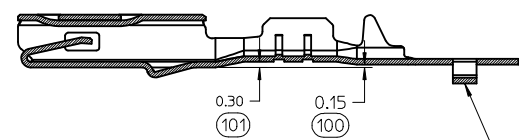
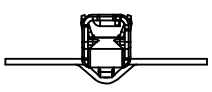

SECTION AA-AA  
**M3 GRIP CODE TERMINAL**  
SEE TABLE (SHEET 2) FOR PART NUMBERS

CARRIER BUMP DIRECTION  
POINTS DOWN FOR TIN PLATED TERMINAL  
POINTS UP FOR PRECIOUS METAL PLATED TERMINAL

<b>ENTER DESCRIPTION</b> EC NO: UAU2017-1076 DRW: N VENKATESH 2017/05/29 CHKD: A. DHIR 2017/05/29 APPR: T. J. SMITH 2017/06/09	QUALITY SYMBOLS ▽=0 ▽=0 ▽=0	GENERAL TOLERANCES (UNLESS SPECIFIED)		DIMENSION STYLE <b>MM ONLY</b>	SCALE <b>5:1</b>	DESIGN UNITS <b>METRIC</b>	THIRD ANGLE PROJECTION		
		4 PLACES ± --- ± ---	3 PLACES ± --- ± ---	2 PLACES ± 0.10 ± ---	1 PLACE ± 0.3 ± ---	DRAWN BY L. PULLIAM	DATE 2005/06/21	TITLE <b>MX150 RECEPTACLE TERMINAL</b>	
		ANGULAR ± 3°		DRAFT WHERE APPLICABLE MUST REMAIN WITHIN DIMENSIONS		CHECKED BY A. DHIR	DATE 2005/06/21	MOLEX INCORPORATED	
		MATERIAL NO. <b>SEE TABLE</b>		DOCUMENT NO. <b>SD-33012-002</b>		SHEET NO. <b>5 OF 5</b>		THIS DRAWING CONTAINS INFORMATION THAT IS PROPRIETARY TO MOLEX INCORPORATED AND SHOULD NOT BE USED WITHOUT WRITTEN PERMISSION	