

THIS DRAWING IS UNPUBLISHED. RELEASED FOR PUBLICATION
 © COPYRIGHT - By - ALL RIGHTS RESERVED.

LOC		DIST		REVISIONS			
AD	00	P	LTR	DESCRIPTION	DATE	DWN	APVD
		F1		REVISED PER ECO-11-004587	11MAR11	RK	HMR

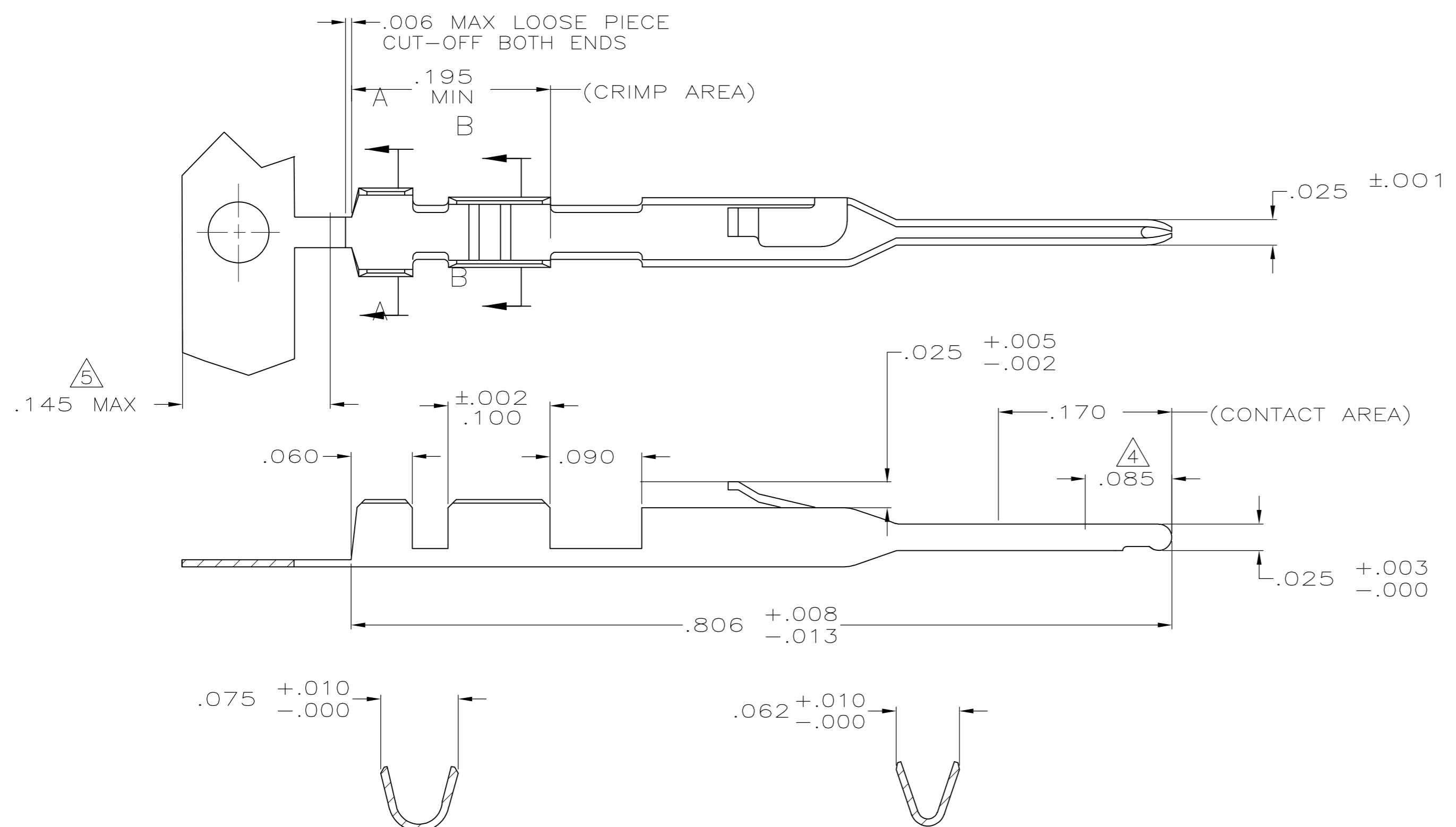

SECTION A-A
 ROTATED 90° CW
 INSULATION RANGE .054 MAX

SECTION B-B
 ROTATED 90° CW
 WIRE RANGE #22-#26

- 1 .000100-.000200 BRIGHT TIN-LEAD OVER .000030 NICKEL ENTIRE CONTACT
- 2 .000015 GOLD IN CONTACT AREA, .000050-.000100 BRIGHT TIN-LEAD IN CRIMP AREA, ALL OVER .000030 NICKEL ENTIRE CONTACT
- 3 .000030 GOLD IN CONTACT AREA, .000050-.000100 BRIGHT TIN-LEAD IN CRIMP AREA, ALL OVER .000030 NICKEL ENTIRE CONTACT
- 4 POINT OF MEASUREMENT FOR PLATING THICKNESS
- 5 GOLD PLATING NOT REQUIRED IN THIS AREA
- 6 .000100-.000200 BRIGHT TIN OVER .000030 NICKEL ENTIRE CONTACT.
- 7 .000015 GOLD IN CONTACT AREA, .000050-.000100 BRIGHT TIN IN CRIMP AREA, ALL OVER .000030 NICKEL ENTIRE CONTACT.
- 8 .000030 GOLD IN CONTACT AREA, .000050-.000100 BRIGHT TIN IN CRIMP AREA, ALL OVER .000030 NICKEL ENTIRE CONTACT.
- 9 .000100-.000200 MATTE TIN OVER .000030 NICKEL ENTIRE CONTACT.
- 10 .000015 GOLD IN CONTACT AREA, .000050-.000100 MATTE TIN IN CRIMP AREA, ALL OVER .000030 NICKEL ENTIRE CONTACT.
- 11 .000030 GOLD IN CONTACT AREA, .000050-.000100 MATTE TIN IN CRIMP AREA, ALL OVER .000030 NICKEL ENTIRE CONTACT.

11	5-104505-7	5-104505-6
10	5-104505-5	5-104505-4
9	5-104505-3	5-104505-2
8	1-104505-3	1-104505-2
7	1-104505-1	1-104505-0
6	104505-9	104505-8
3	104505-7	104505-6
2	104505-5	104505-4
1	104505-3	104505-2
FINISH	LOOSE PIECE PART NUMBER	PART NUMBER

THIS DRAWING IS A CONTROLLED DOCUMENT.

DWN	D KEITZER	12-14-88
CHK	S. SHUEY	12-15-88
APVD	C.SINISI	12-16-88
PRODUCT SPEC	-	
APPLICATION SPEC	-	
WEIGHT	-	-
MATERIAL	PHOS BRONZE	FINISH SEE TABLE

TE Connectivity

PIN CONTACT, AMPMODU, MTE

SIZE	A2	CAGE CODE	00779	DRAWING NO	C=104505	RESTRICTED TO	-
SCALE	10:1	SHEET	1 of 1	REV	F1		

CUSTOMER DRAWING

104505

Mouser Electronics

Authorized Distributor

Click to View Pricing, Inventory, Delivery & Lifecycle Information:

[TE Connectivity:](#)

[104505-2](#)