



83132 / 83133 / 83134 Output on front face 831340 Part number



Double break switching
Choice of actuators for symmetrical mounting
Options for operation in stable positions

Part numbers

	Type	Function	Connections
83132030	Side outputs 831320	I (changeover)	W2
CONTACT US	Side outputs 831320	I (changeover)	X1
83133035	Rear outputs 831330	I (changeover)	W2
MADE TO ORDER	Rear outputs 831330	I (changeover)	X1
CONTACT US	Output on front face 831340	I (changeover)	W2
MADE TO ORDER	Output on front face 831340	I (changeover)	X1

Specifications

Electrical characteristics

Rating nominal / 250 V (A)	5
Rating thermal / 250 V (A)	11

Mechanical characteristics

Maximum operating force (N)	1,6
Min. Release force (N)	0,4
Max. permitted overtravel force (N)	10
Maximum rest position (mm)	8,10
Operating position (mm)	7,35 ^{+0,25}
Maximum differential travel (mm)	0,45
Min. overtravel (mm)	0,27
Ambient operating temperature (°C)	-20 → +125
Mechanical life (operations)	10 ⁷
Contact gap (mm)	0,3 x 2
Weight (g)	1,8

Additional specifications

Components

Material

- Case : glass-filled polyamide
- Contacts : silver
- Cupro-nickel terminals

Lever

- Flat : stainless steel
- Roller : polyamide

Accessories : stainless steel

Principles



Dimensions (mm)

Product

831340

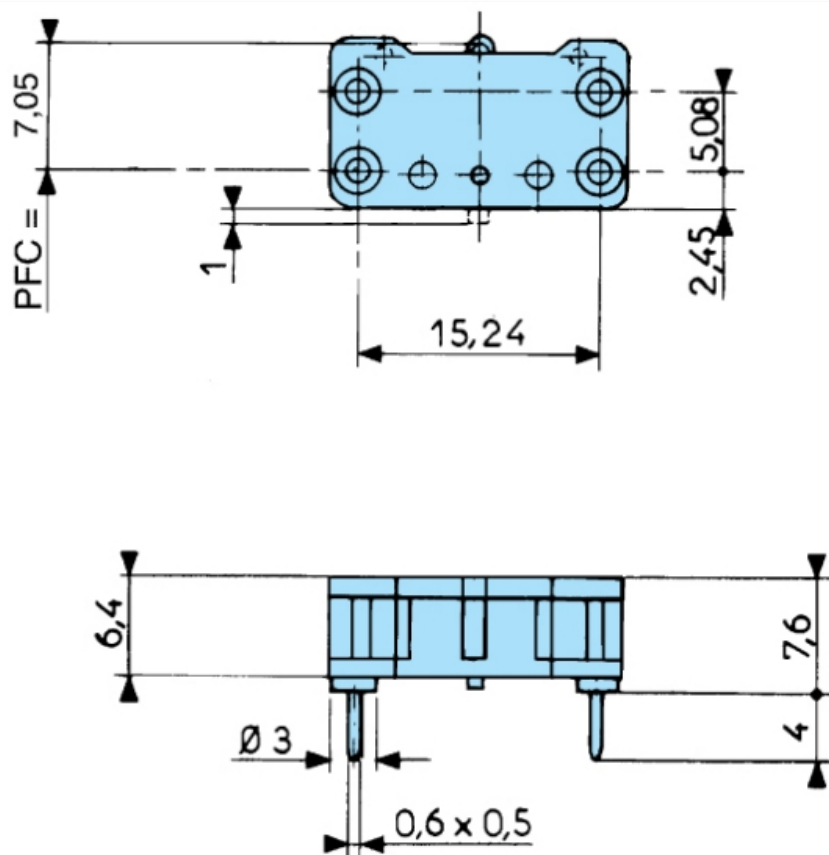

Dimensions (mm)

Connections

X1 for printed circuit board (83134)

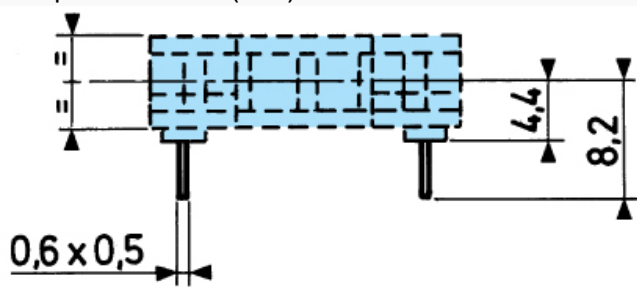

Dimensions (mm)

Actuators and fixing positions

54A

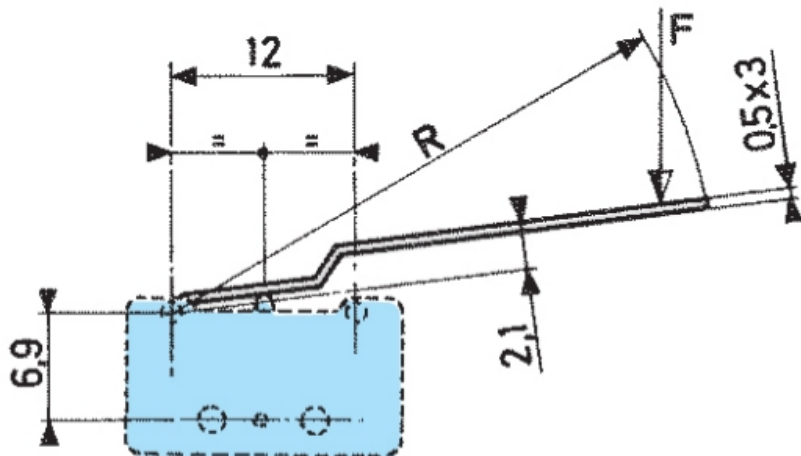

Dimensions (mm)

Mounting accessories

For 831320 and 831330

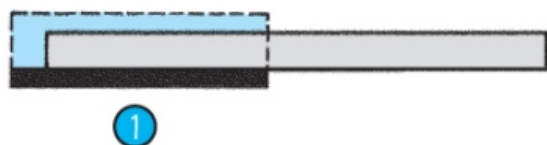

N°	Legend
①	Cover

Dimensions (mm)

Actuators and fixing positions

54B

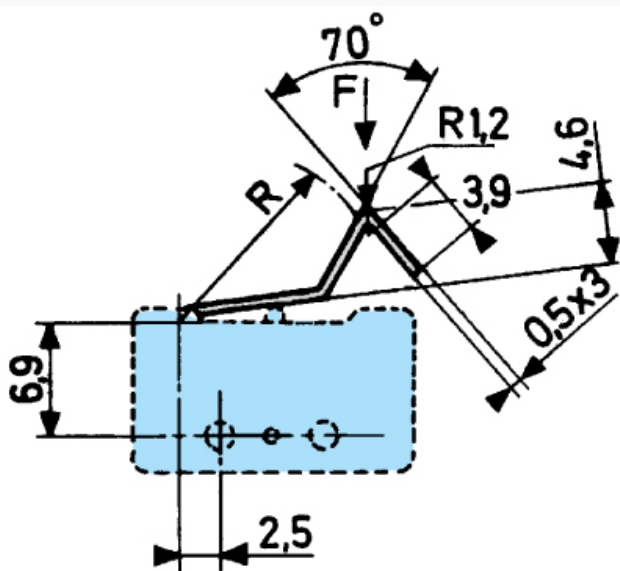

Dimensions (mm)

Actuators and fixing positions

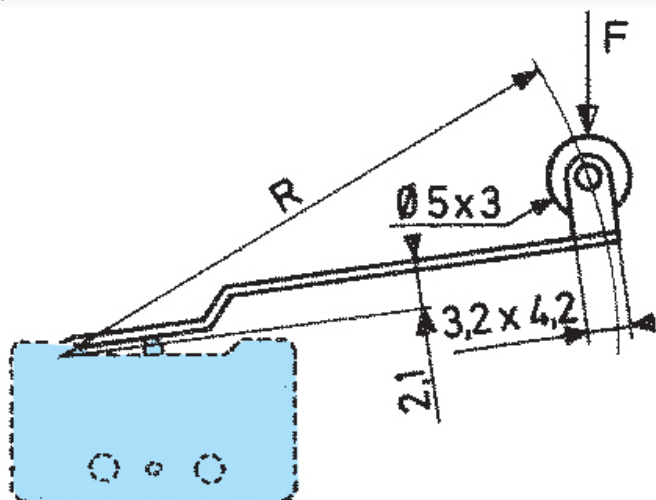

Dimensions (mm)

Mounting accessories

For 831340

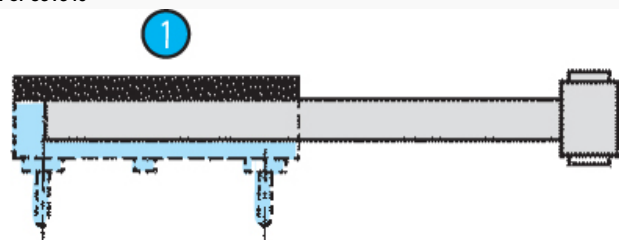

N°	Legend
1	Cover

Dimensions (mm)

Actuators and fixing positions

54A2

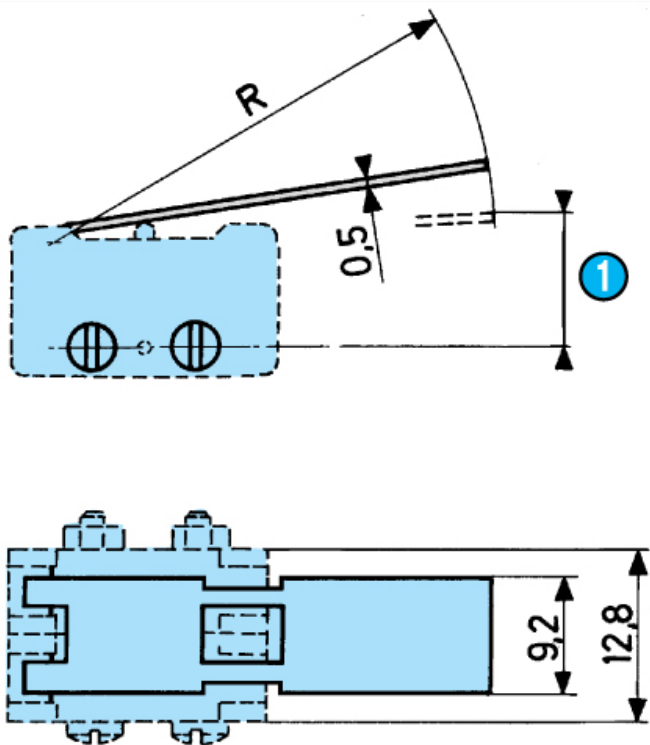

N°	Legend
1	Tripping point

Dimensions (mm)

Actuators and fixing positions

54A3

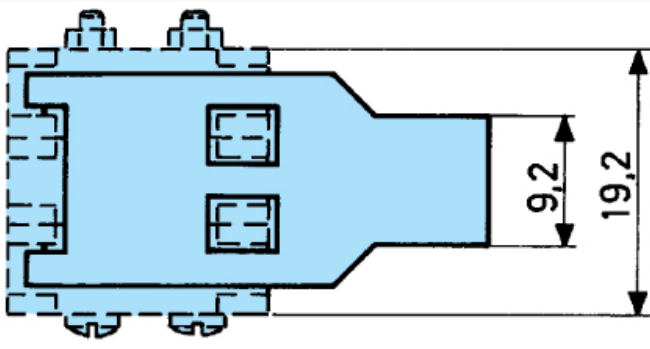

Curves

Operating curve for types
831320 - 831330 - 831340

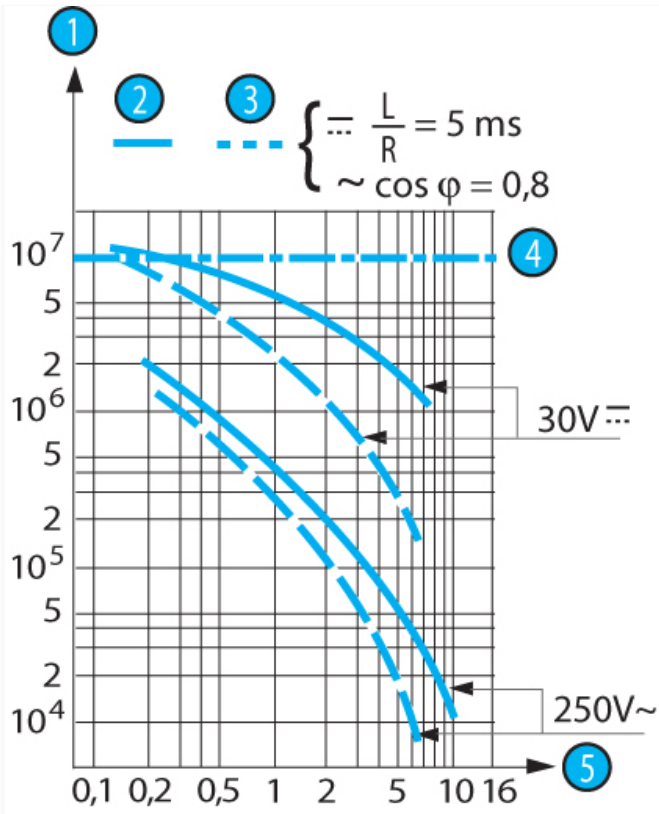

N°	Legend
1	Number of cycles
2	Resistive circuit
3	Inductive circuit
4	Mechanical life limit
5	Current in Amps

Connections

Actuators and fixing positions

Part numbers for standard actuators	70 514 175	70 514 194	70 514 181	70 514 182
Actuators	Plain 54A R14.75	Plain 54A R35.75	Tip-mounted in-line roller 54E R7.5	Tip-mounted in-line roller 54E R14.1
	83 132 0 83 133 0 83 134 0	83 132 0 83 133 0 83 134 0	83 132 0 83 133 0 83 134 0	83 132 0 83 133 0 83 134 0
Tripping point	9.5 ^{+0.8} 9.7 ^{+0.8}	10 ^{+1.5} 9.7 ^{+0.55}	14.2 ^{+0.5} 13.0 ^{+0.5}	15.5 ^{+0.8} 15.2 ^{+0.8}
Operating force max. N	0.8	0.34	1.6	0.8
Release force min. N	0.16	0.06	0.32	0.17
Pre-travel max. mm	2.15	5.15	1.1	2.05
Differential travel mm	1 ^{+0.3}	2.1 ^{+0.65}	0.5 ^{+0.15}	0.95 ^{+0.3}
Total travel max. mm	2.8	6.8	1.45	1.45
Actuators	54B R13.17	2-pole 54A2 R30	3-pole 54A3 R30	Side fixing plate (0.4 mm thick) 54Y
	83 132 0 83 133 0 83 134 0	83 132 0 83 133 0 83 134 0	83 132 0 83 133 0 83 134 0	
Tripping point	12.7 ^{+0.8} 12.4 ^{+0.8}	8.8 ^{+0.8}	8.8 ^{+0.8}	
Operating force max. N	0.85	0.8	1.2	
Release force min. N	0.18	0.16	0.24	
Pre-travel max. mm	2.05	4.3	4.3	
Differential travel mm	0.95 ^{+0.3}	2 ^{+0.35}	2 ^{+0.35}	
Total travel max. mm	2.7	5.75	5.75	

Unless mentioned specifically, the levers are mounted in the position illustrated on the dimension diagrams (standard mounting). We recommend that these levers are assembled in our workshops.

Other information

Mounting - Operation

Product adaptations



- Special levers
- Reinforced spring
- Approvals : UL - cUL

Mouser Electronics

Authorized Distributor

Click to View Pricing, Inventory, Delivery & Lifecycle Information:

[Crouzet:](#)

[831340C2.0](#)