

Customer Information Sheet

DRAWING No.: M80-560XX05

SHEET 2 OF 2

IF IN DOUBT - ASK

(C)

NOT TO SCALE

THIRD ANGLE PROJECTION

ALL DIMENSIONS IN mm

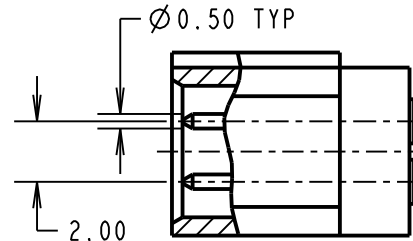
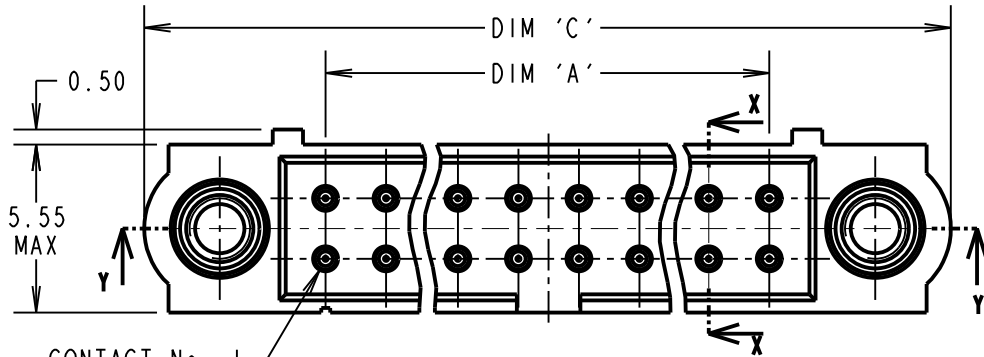

PART SECTION X-X

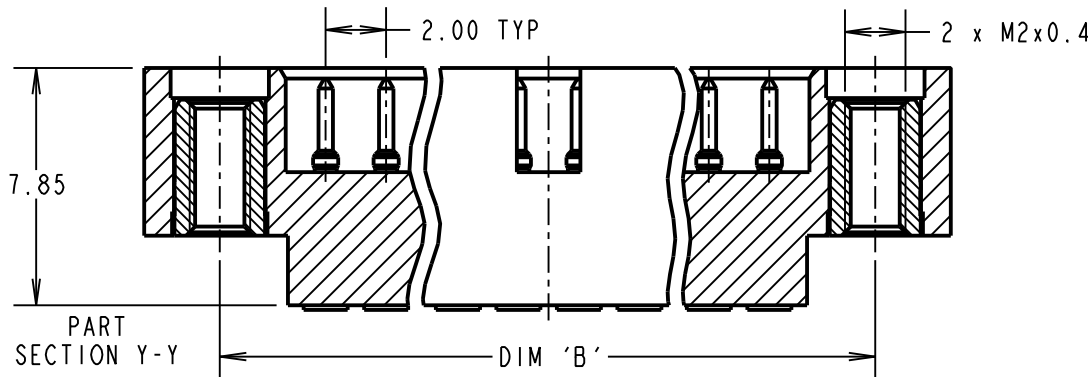

PART SECTION Y-Y

SPECIFICATIONS:
MATERIAL:
 Moulding = GLASS-FILLED PPS, UL94V-0, BLACK
 CONTACT = BRASS
 JACKSCREW = STAINLESS STEEL
FINISH:
 05 = 0.25-0.3µ GOLD
ELECTRICAL:
 CURRENT RATING AT 25°C = 3.0A MAX
 CURRENT RATING AT 85°C = 2.2A MAX
 WORKING VOLTAGE = 800V AC/DC
 VOLTAGE PROOF = 1200V AC/DC
 CONTACT RESISTANCE = 25mΩ MAX
 INSULATION RESISTANCE = 100MΩ MIN
MECHANICAL:
 DURABILITY = 500 OPERATIONS
ENVIRONMENTAL:
 TEMPERATURE RANGE = -55°C TO +125°C
PACKING:
 LOOSE
 FOR COMPLETE SPECIFICATION, SEE COMPONENT SPECIFICATION C005XX (LATEST ISSUE)

NOTES:

- CONNECTORS ARE SUPPLIED WITH CONTACTS LOOSE.
- FOR EXTRA CONTACTS, USE PART NUMBER M80-1940005 FOR M80-560XX05.
- RECOMMENDED WIRE TYPE = BS 3G 210 TYPE A, PTFE INSULATED 22 AWG. MAX INSULATION DIAMETER = Ø1.10mm, STRIP WIRE BY 2.00mm.
- RECOMMENDED HAND CRIMP TOOL = M22520/2-01 WITH POSITIONER Z80-193. REFER TO TOOLING INSTRUCTION SHEET IS-01 FOR COMPLETE CRIMPING INSTRUCTIONS.
- CONTACT INSERTION AND EXTRACTION TOOL = Z80-280. REFER TO TOOLING INSTRUCTION SHEET IS-25 FOR ASSEMBLY INSTRUCTIONS.

DIMENSION	CALCULATION
DIM 'A'	TOTAL No. OF CONTACTS - 2
DIM 'B'	TOTAL No. OF CONTACTS + 5
DIM 'C'	TOTAL No. OF CONTACTS + 10

EXAMPLE: CONNECTOR WITH 20 GOLD CONTACTS, M80-5602005:
 DIM 'A' = 18.00mm, DIM 'B' = 25.00mm,
 DIM 'C' = 30.00mm

ORDER CODE:
M80-560XX05

TOTAL No. OF CONTACTS —
 04 TO 50
 (EVEN NUMBERS ONLY)

MSP	3	23.09.16	20112
NAME	ISS.	DATE	C/NOTE
APPROVED: M.PERREN			
CHECKED: M.PLESTED			
DRAWN: W. J. BOURNE			
CUSTOMER REF.:			
ASSEMBLY DRG:			

HARWIN

www.harwin.com
 technical@harwin.com

THIS DRAWING AND ANY INFORMATION OR DESCRIPTIVE MATTER SET OUT HEREON ARE CONFIDENTIAL AND COPYRIGHT PROPERTY OF THE HARWIN GROUP AND MUST NOT BE DISCLOSED, LOANED, COPIED OR USED FOR MANUFACTURING, TENDERING OR FOR ANY OTHER PURPOSE WITHOUT THEIR WRITTEN PERMISSION.

TOLERANCES
 X. = ±1mm
 X.X = ±0.50mm
 X.XX = ±0.10mm
 X.XXX = ±0.01mm
 ANGLES = ±5°
 UNLESS STATED

MATERIAL:
 SEE ABOVE
FINISH: SEE ABOVE
S/AREA: mm²

TITLE: JACKSCREW DATAMATE DIL CRIMP (LARGE BORE) MALE ASSEMBLY
DRAWING NUMBER:
M80-560XX05
 SHT 2 OF 2

Mouser Electronics

Authorized Distributor

Click to View Pricing, Inventory, Delivery & Lifecycle Information:

[Harwin:](#)

[M80-5600605](#) [M80-5603405](#) [M80-5604205](#) [M80-5601005](#) [M80-5601405](#) [M80-5602605](#) [M80-5602005](#) [M80-5605005](#) [M80-5601205](#) [M80-5601805](#) [M80-5600405](#) [M80-5600805](#) [M80-5602405](#) [M80-5601605](#)