

PART NUMBER	REV	FIRST USED	TERMINATOR	FEED TYPE	DESCRIPTION
1238057-1	F	-	LEADMAKER	MECH POST FEED	CUTS CARRIER
1238057-2	F	-	BENCH	MECH PRE FEED	CUTS CARRIER
1238057-6	F	-	LEADMAKER	MECH POST FEED	CONTINUOUS CARRIER
7-1238057-1	F	-	LEADMAKER	MECH POST FEED	-1 AND SPARE PARTS
7-1238057-2	F	-	BENCH	MECH PRE FEED	-2 AND SPARE PARTS
7-1238057-6	F	-	LEADMAKER	MECH POST FEED	-6 AND SPARE PARTS
7-1238057-7	A	-	-	-	SPARE PARTS KIT

**CRIMP DATA (AMP TERMINAL)**  
 TERMINAL NAME: PIN CONTACT SIZE 20 DF, 24-28 WIRE

CRIMP	SIZE	TYPE	RANGE
WIRE	1.07 [.042 IN]	F	28-24
INSUL	1.40 [.055 IN]	0	0.8-1.0 [.030-.040 IN]

WIRE STRIP LENGTH: 2.13-2.64 mm  
 APPL INSTRUCTION: 408-8322

TERMINAL APPL SPEC	114-10000	FEED	7.6 [.300 IN]
--------------------	-----------	------	---------------

**TERMINALS APPLIED**

PIN	SOCKET	-	-	-
215862	166052	-	-	-
166054	745502	-	-	-
1658540	1658538	-	-	-
66507	66505	-	-	-

WIRE SIZE mm <sup>2</sup> AWG	CRIMP HEIGHT	PIN PN & LENGTH [IN]
24	0.81 ±0.05 [.032 ±.002 IN]	1-354779-8 [.3080]
26	0.74 ±0.05 [.029 ±.002 IN]	2-354779-2 [.3100]
28	0.74 ±0.05 [.029 ±.002 IN]	2-354779-3 [.3105]

SET UP GAGE	LAYOUT
458637-3	L2394

- RECOMMENDED SPARE PARTS.
- GREASE RAM, CAM, CAM FOLLOWER AND FEED ROD LIGHTLY.
- LUBRICATE DAILY PER THE APPLICATOR INSTRUCTION SHEET SUPPLIED WITH THE APPLICATOR.

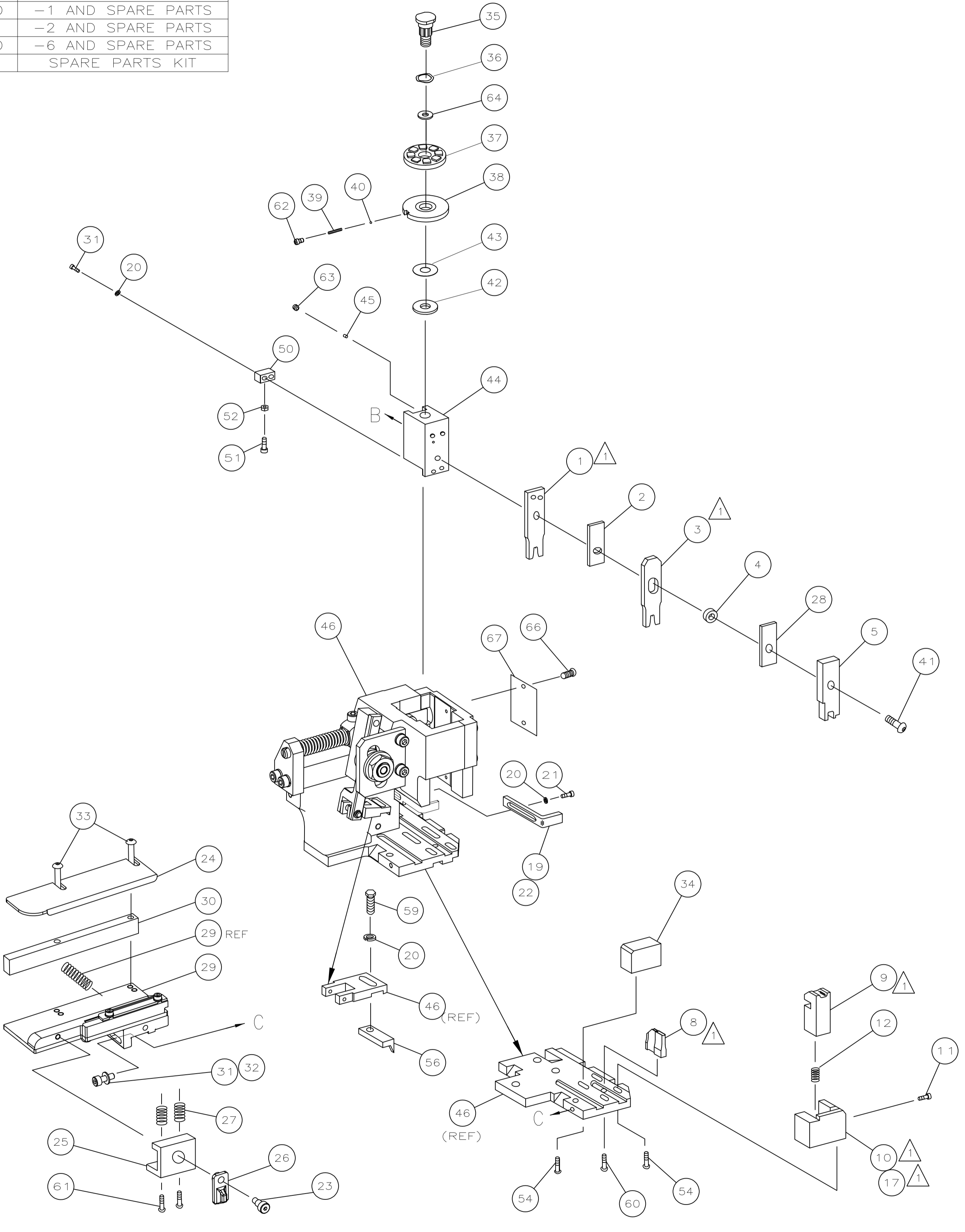
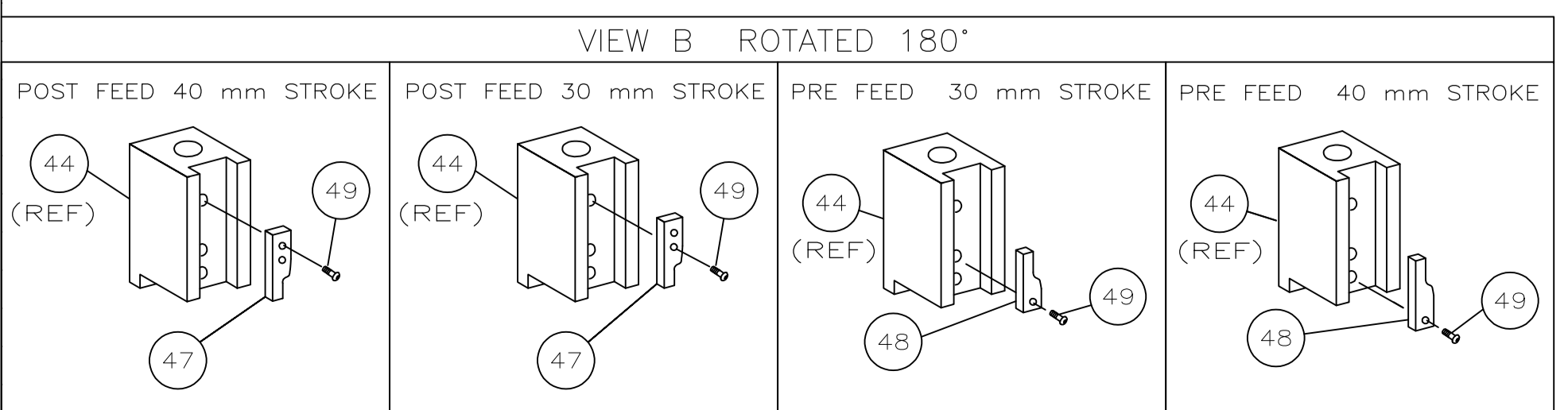

QTY	REQD	PER	ASSY	PART NO	DESCRIPTION	ITEM NO
1	1	1	1	1	1	73
1	1	1	1	1	1	72
1	1	1	1	1	1	71
						70
						69
						68
1	1	1	1	1	1	67
2	2	2	2	2	2	66
						65
1	1	1	1	1	1	64
1	1	1	1	1	1	63
1	1	1	1	1	1	62
2	2	2	2	2	2	61
1	1	1	1	1	1	60
1	1	1	1	1	1	59
						58
						57
1	1	1	1	1	1	56
						55
4	4	4	4	4	4	54
						53
1	1	1	1	1	1	52
1	1	1	1	1	1	51
1	1	1	1	1	1	50
1	1	1	1	1	1	49
1	1	1	1	1	1	48
1	1	1	1	1	1	47
1	1	1	1	1	1	46
1	1	1	1	1	1	45
1	1	1	1	1	1	44
1	1	1	1	1	1	43
1	1	1	1	1	1	42
1	1	1	1	1	1	41
1	1	1	1	1	1	40
1	1	1	1	1	1	39
1	1	1	1	1	1	38
1	1	1	1	1	1	37
1	1	1	1	1	1	36
1	1	1	1	1	1	35
1	1	1	1	1	1	34
2	2	2	2	2	2	33
1	1	1	1	1	1	32
3	3	3	3	3	3	31
1	1	1	1	1	1	30
1	1	1	1	1	1	29
1	1	1	1	1	1	28
2	2	2	2	2	2	27
1	1	1	1	1	1	26
1	1	1	1	1	1	25
1	1	1	1	1	1	24
1	1	1	1	1	1	23
1	1	1	1	1	1	22
1	1	1	1	1	1	21
4	4	4	4	4	4	20
1	1	1	1	1	1	19
1	1	1	1	1	1	18
1	1	1	1	1	1	17
1	1	1	1	1	1	16
						15
						14
						13
1	1	1	1	1	1	12
1	1	1	1	1	1	11
1	1	1	1	1	1	10
1	1	1	1	1	1	9
1	2	2	2	1	1	8
						7
						6
1	1	1	1	1	1	5
1	1	1	1	1	1	4
1	2	2	2	1	1	3
1	1	1	1	1	1	2
1	2	2	2	1	1	1

THIS DRAWING IS A CONTROLLED DOCUMENT.

DIMENSIONS: INCHES	TOLERANCES UNLESS OTHERWISE SPECIFIED:	0 PLC ± .005	1 PLC ± .005	2 PLC ± .005	3 PLC ± .005	4 PLC ± .005	ANGLES ± .005
--------------------	----------------------------------------	--------------	--------------	--------------	--------------	--------------	---------------

MATERIAL: - FINISH: -

APPROVED: T. ELBIN

DATE: 01JUN00

NAME: SIDE FEED HD-1 APPLICATOR

SIZE: A1

SCALE: -

SHEET: 1 of 1

REV: F1

# Mouser Electronics

Authorized Distributor

Click to View Pricing, Inventory, Delivery & Lifecycle Information:

[TE Connectivity:](#)

[1238057-1](#)