

DELPHI

Assembly Manuals

Connector 6-way

for 150/280 Terminals (BTS and similar)

sealed

Assembly at harness plant

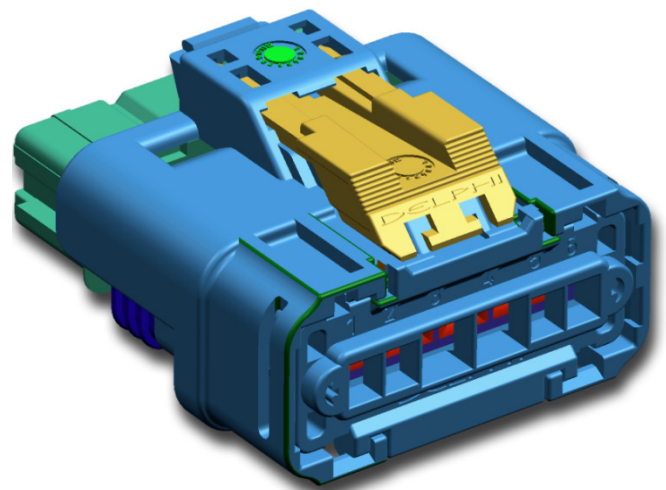

D

REV 04 - May 2012
ADI-15458155-2

TABLE OF CONTENTS

Components (exploded view)	3
List of components	4
View of versions	5
Delivery status, descriptions	6,7
ASSEMBLY SEQUENCE:	8
step 1: inserting <i>Female Terminals 150</i>	8
step 2a: inserting <i>Female Terminals 280</i>	9
step 2b: inserting <i>Cavity Plug</i>	10
step 3: locking <i>SL</i>	11
step 4: locking <i>Cable Caps</i>	12,13
step 5: strapping cables	14,15
step 6: electrical and mechanical tests	16
Requirements for Connector 6-way testing	17, 18, 19, 20
DISASSEMBLY SEQUENCE:	21
step D-1: removing cable tie	22, 23
step D-2: removing <i>Cable Caps</i>	24, 25
step D-3: unlocking <i>SL</i>	26
step D-4: removing <i>Female Terminals 280</i>	27
step D-5: removing <i>Female Terminals 150</i>	28
Table of tools	29, 30
Packaging	31
Revisions	32

The information contained in these assembly instructions is subject to alteration without prior notice and does not represent any obligation on the part of DELPHI. All information is correct at the time of releasing. Reprinting or translation is not permitted without written permission from DELPHI. © Copyright 2012 DELPHI. All rights reserved.

EXPLODED VIEW

ATTENTION.
Optional Cable Caps are not available

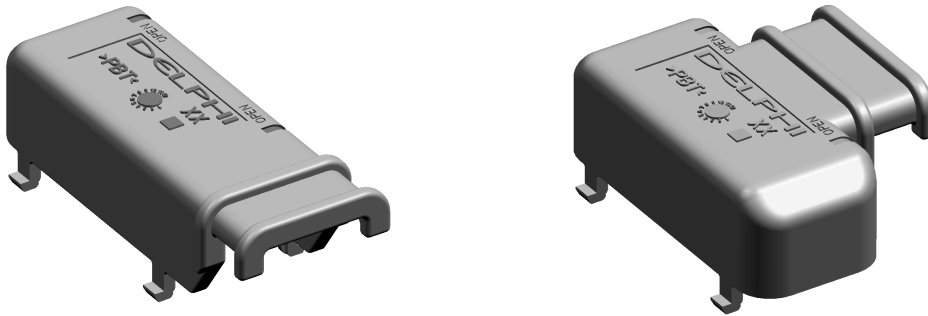

Cavity Plug

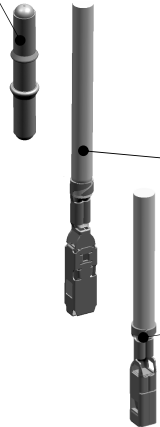

Female Terminal 280
(BTS and similar)

Female Terminal 150
(BTS and similar)

Receptacle Housing 6-way
PART-NO. see page 4

CPA (optional)
See page 4

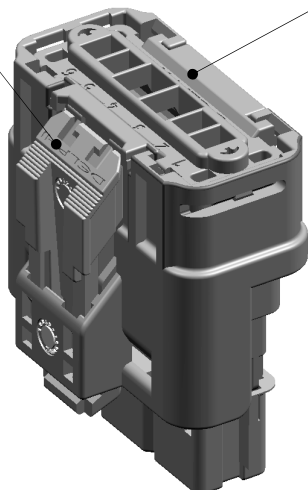

STORAGE CONDITIONS BEFORE ASSEMBLY	
TEMPERATURE:	+18°C to +55°C
RELATIVE HUMIDITY:	45% to 85%
ATMOSPHERIC PRESSURE:	860 hPa to 1060 hPa
STORAGE TIME:	min. 24 hours

**Pictures used in this Assembly Manual and original parts may differ in some details,
This difference has no influence on the assembly process .**

LIST OF COMPONENTS

Component (pre-assembled)	DELPHI Part-No.	Amount	
Housing 6-way	15458151	(mixed 1.5/2.8 without CPA, Black)	1
	15458152	(mixed 1.5/2.8 without CPA, Grey)	
	15458153	(mixed 1.5/2.8 without CPA, Blue)	
	15458163	(mixed 1.5/2.8 with CPA, Black)	
	15458164	(mixed 1.5/2.8 with CPA, Grey)	
	15458165	(mixed 1.5/2.8 with CPA, Blue)	
		(only 1.5 line without CPA, Yellow)	
	15440054	(only 1.5 line without CPA, Green)	
	15440055	(only 1.5 line without CPA, Brown)	
	15458160	(only 1.5 line with CPA, Yellow)	
	15458161	(only 1.5 line with CPA, Green)	
	15458162	(only 1.5 line with CPA, Brown)	
	15427148	(2 cavities closed without CPA)	
	15458159	(2 cavities closed with CPA)	

Terminal 150 (BTS and similar):

max. 6

REF. DELPHI DELPHI N°	REVISION PART-REV	DATE DATE	GAMME SERTISSAGE CRIMPING RANGE (mm ²)	MATIERE MATERIAL	REVETEMENT PLATING
15414369	04	10MR05	0.50	CuNi 3Si XCrNi	Sn 3μ -
15414370	04	10MR05	0.60 - 1.00	CuNi 3Si XCrNi	Sn 3μ -
15414435	04	10MR05	1.50 - (2.00)*	CuNi 3Si XCrNi	Sn 3μ -
15414437	04	10MR05	0.50	CuNi 3Si XCrNi	Au 1.27μ mini/Sn 3μ -
15414438	04	10MR05	0.60 - 1.00	CuNi 3Si XCrNi	Au 1.27μ mini/Sn 3μ -
15414439	04	10MR05	1.50 - (2.00)*	CuNi 3Si XCrNi	Au 1.27μ mini/Sn 3μ -
13626722	01	01FE07	0.50	CuNi 3Si XCrNi	Au 1.27μ mini/Sn 3μ GREASE -
13626723	01	01FE07	0.60 - 1.00	CuNi 3Si XCrNi	Au 1.27μ mini/Sn 3μ GREASE -
13626724	01	01FE07	1.50 - (2.00)*	CuNi 3Si XCrNi	Au 1.27μ mini/Sn 3μ GREASE -

Terminal 280 (BTS and similar):

max. 2

REF. DELPHI DELPHI N°	REVISION PART-REV	DATE DATE	GAMME SERTISSAGE CRIMPING RANGE (MM ²)	TYP	MATIERE MATERIAL	REVETEMENT PLATING
15492979	02	20N006	0.60 - 1.00		CUNI3S11MG XCRNI	SN 3μ -
15492980	02	20N006	1.40 - 2.50		CUNI3S11MG XCRNI	SN 3μ -
15492983	02	20N006	0.60 - 1.00		CUNI3S11MG XCRNI	AU 1μ MINI/SN 3μ -
15492984	02	20N006	1.40 - 2.50	HVR	CUNI3S11MG XCRNI	AU 1μ MINI/SN 3μ -
13624893	01	19MY07	1.40 - 2.50		CUNI3S11MG XCRNI	AU 1μ MINI/SN 3μ -

DELIVERY STATUS, PART DESCRIPTIONS

DELIVERY STATUS

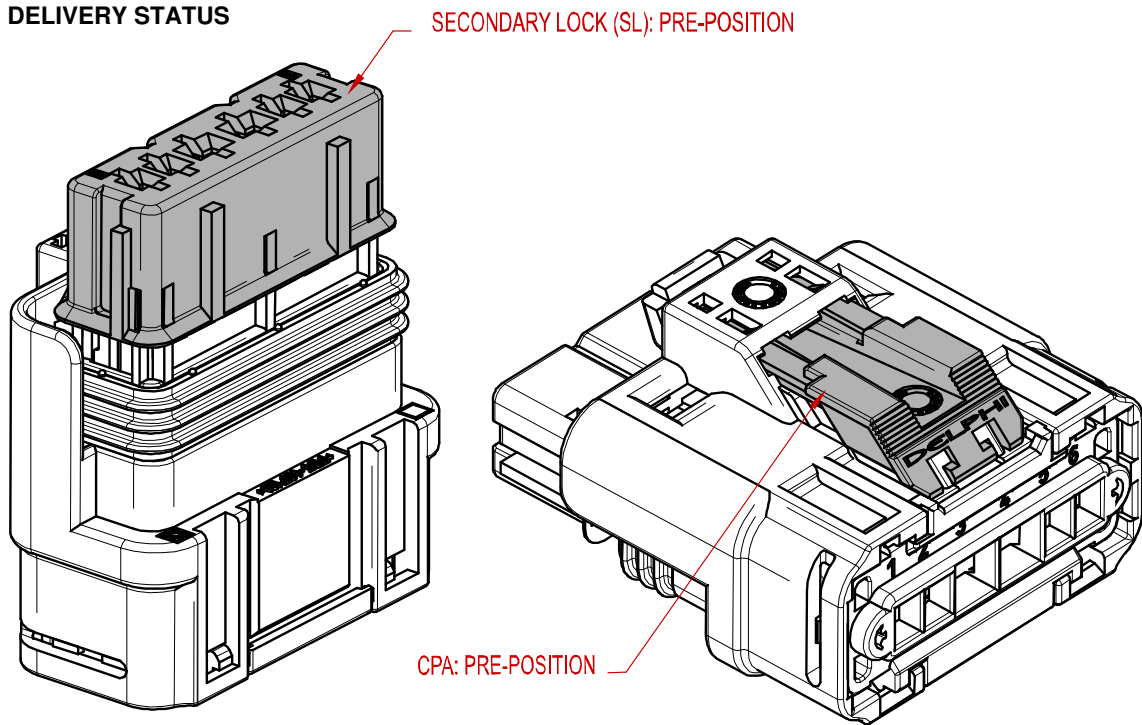

PART DESCRIPTIONS

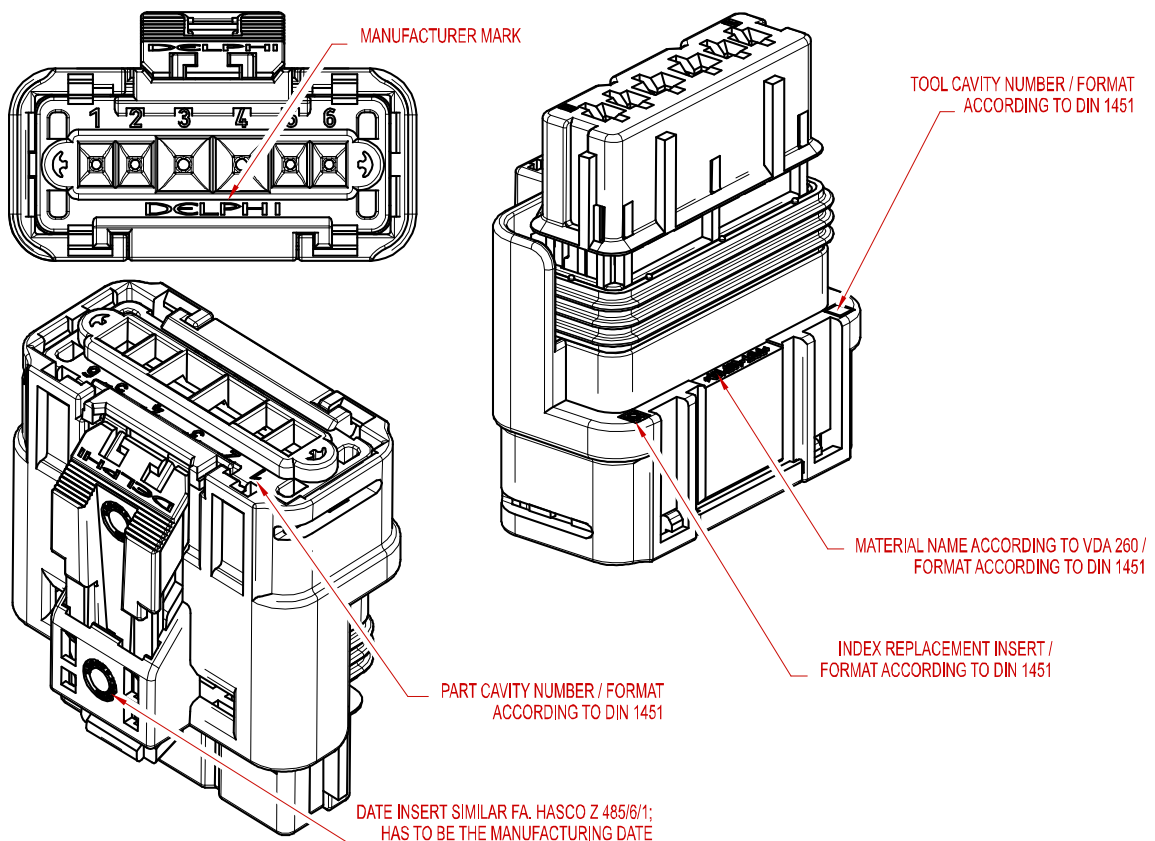

DELIVERY STATUS, PART DESCRIPTIONS

CPA DELIVERY STATUS

OK

CPA locked in pre-position-windows

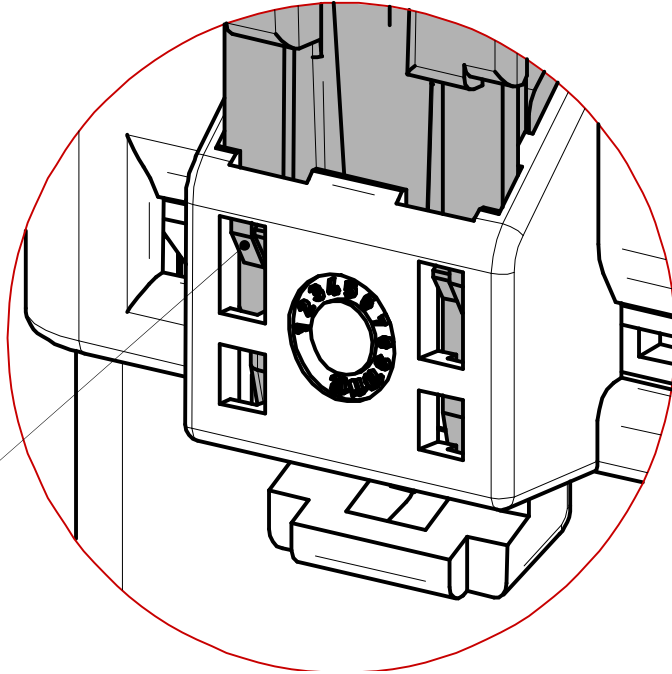

CPA locked in end-position-windows

NOK

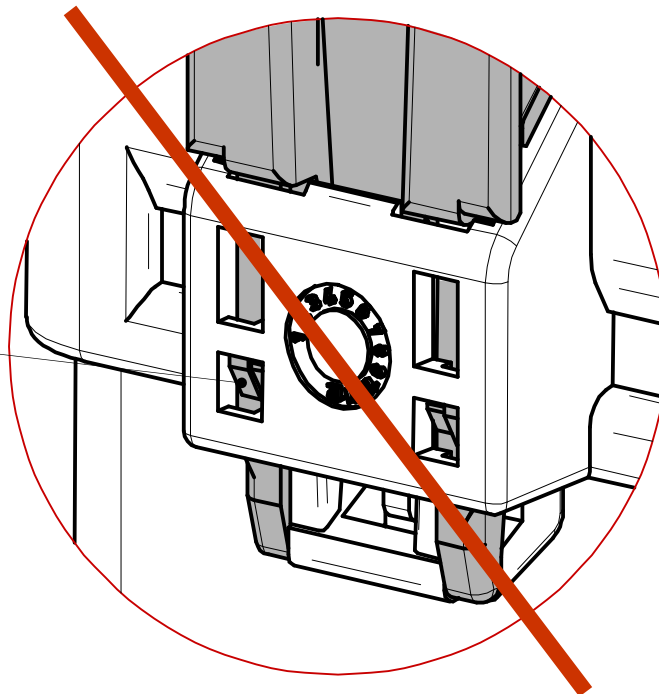

INSERTING TERMINAL 150

A
S
S
E
M
B
L
Y

Validated up to 4 cycles max for insertion/removing Terminal.

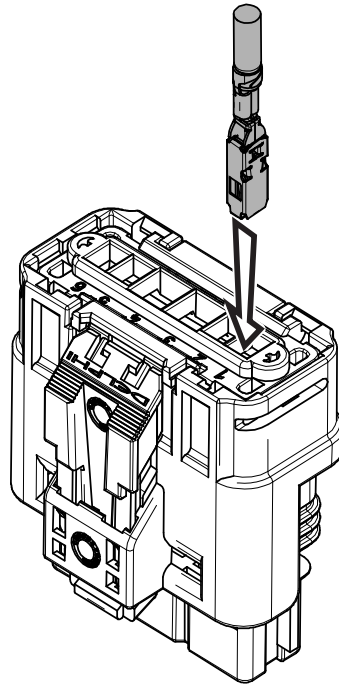

1 Insert the *Terminals 150* (or *Cavity Plug* for 4-way version - see page 10) through the cavities by respecting the *Terminal* polarization.

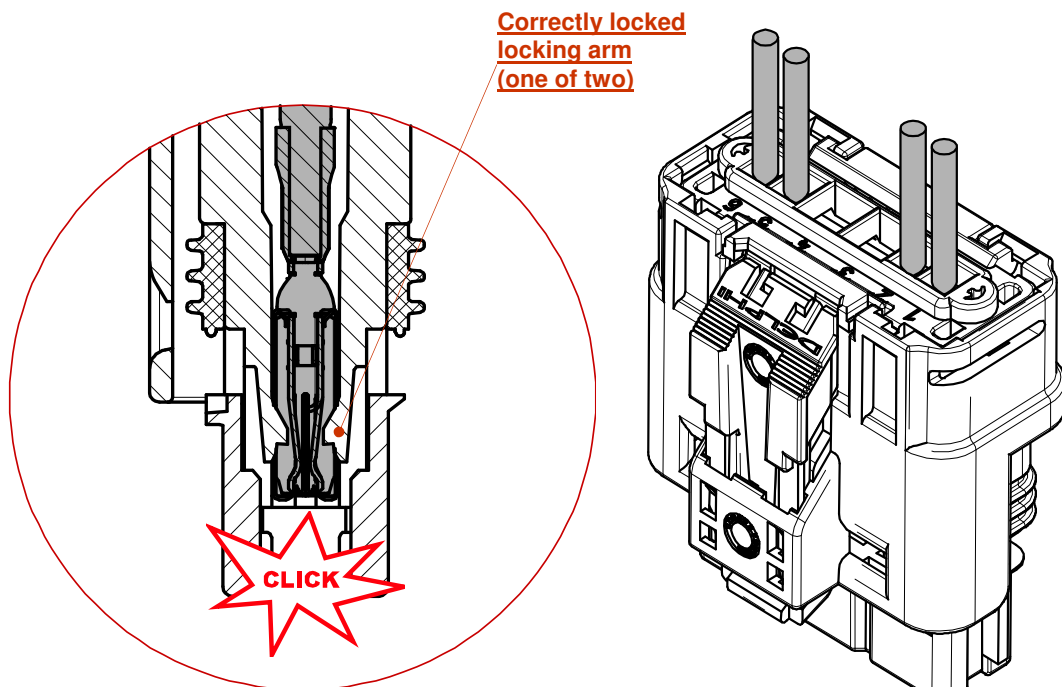

Step completed.

INSERTING TERMINAL 280

**A
S
S
E
M
B
L
Y**

Validated up to 4 cycles max for insertion / extraction Terminal.

Only two positions of the Terminal are correct !

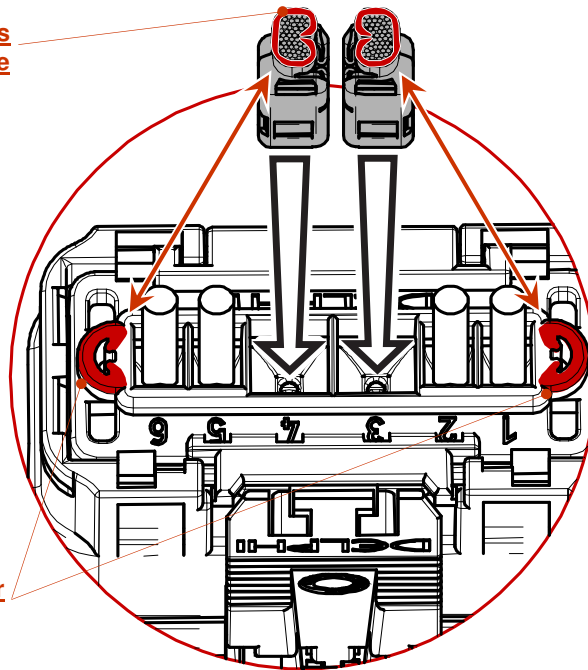
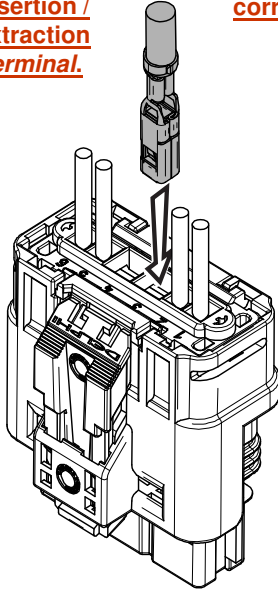

Crimp-similar shapes

Insert the *Terminals 280* through the 6-way cavities by respecting the *Terminal* polarization (make use of housing shapes similar to terminal crimping area to find the right orientation).

2a

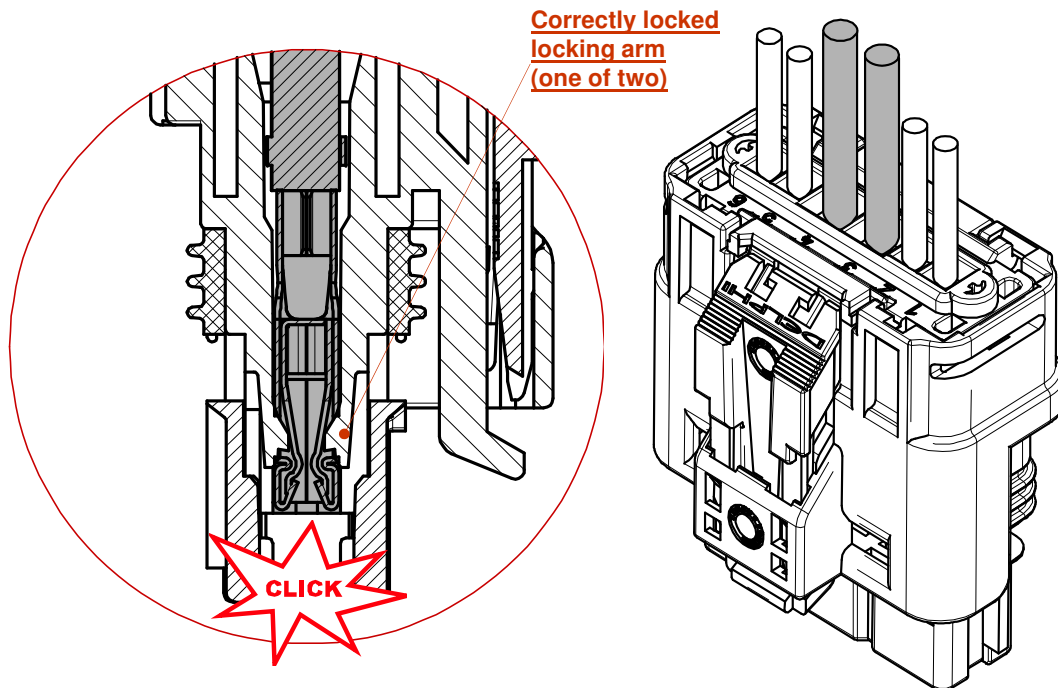

Step completed.

INSERTING CAVITY PLUG

Connector 4-way version
(2 blank cavities)

Cavity Plug:
210A015019
9628693180

Blank cavities

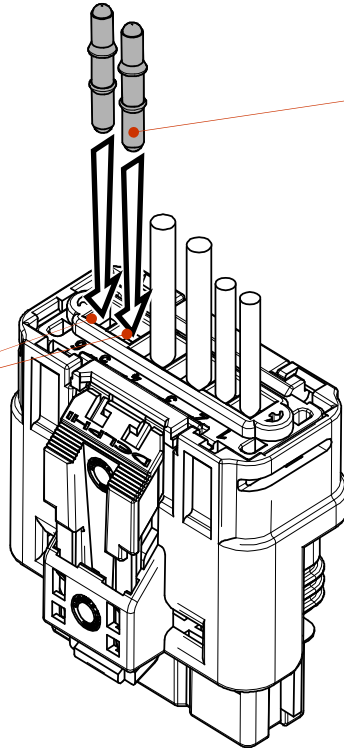

2b

Insert the *Cavity Plug* into all empty cavities.

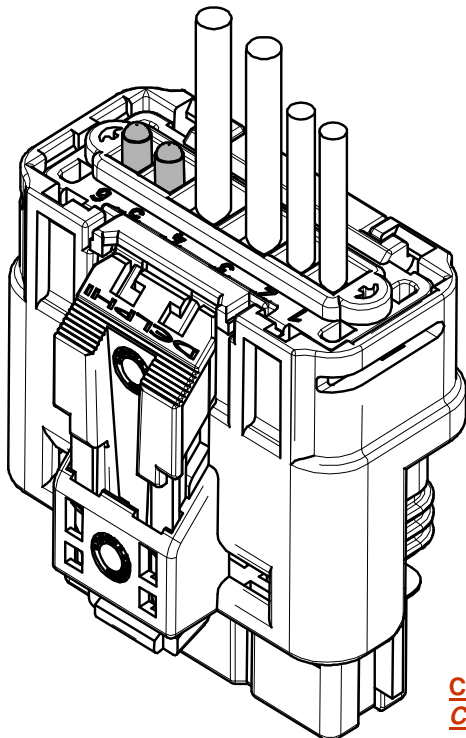

Step completed.

0.5 MAX

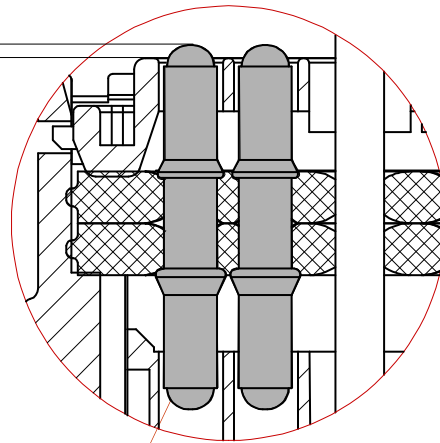

Correctly inserted
Cavity Plug

A
S
S
E
M
B
L
Y

LOCKING SL

Validated up to 10 cycles max for opening and closing SL

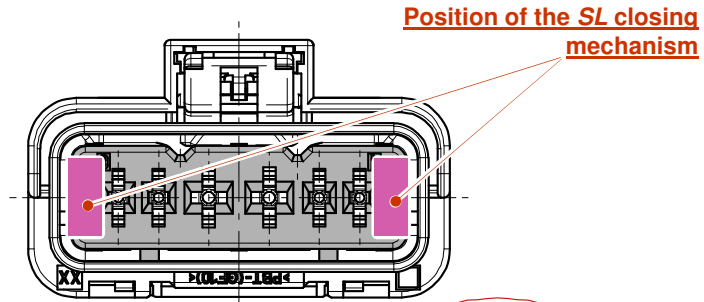
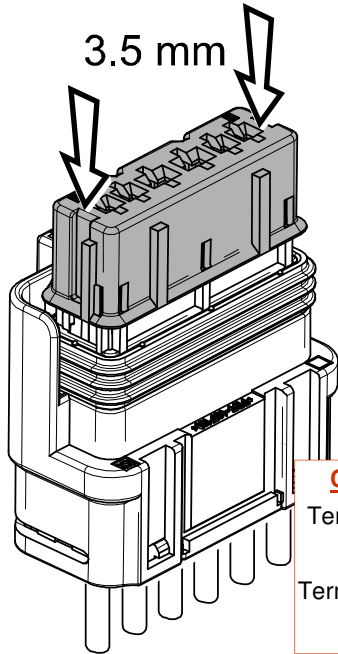

Position of the SL closing mechanism

Closing force of SL:
Terminals in right position
 $15 < F < 40 \text{ N}$
Terminals in wrong position
 $F > 100 \text{ N}$

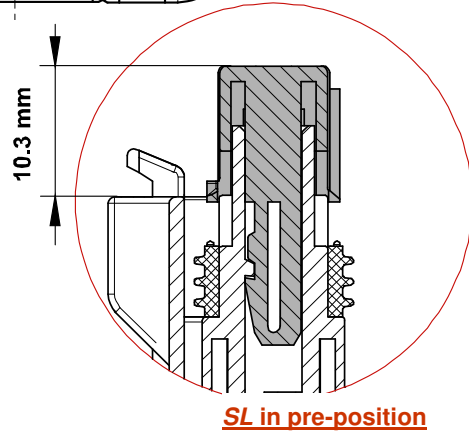

10.3 mm

SL in pre-position

3

Push the SL until it is correctly locked in the end position.

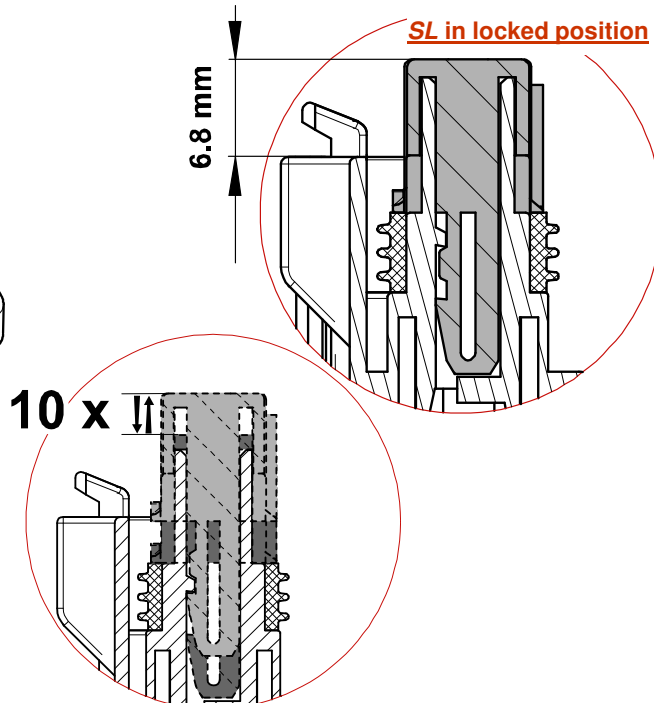
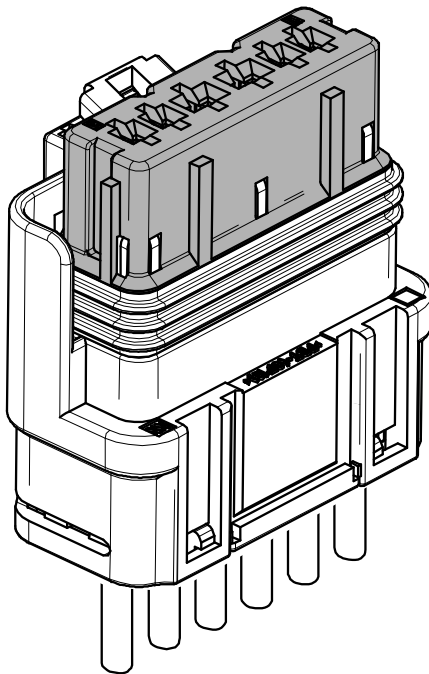

SL in locked position

6.8 mm

10 x

NOTE: Validated for 10 cycles opening and closing SL!

Step completed.

LOCKING CABLE CAP

A
S
E
M
B
L
Y

OPTIONAL (Cable Cap TYPE A)

ATTENTION !
CABLE CAP IS NOT AVAILABLE

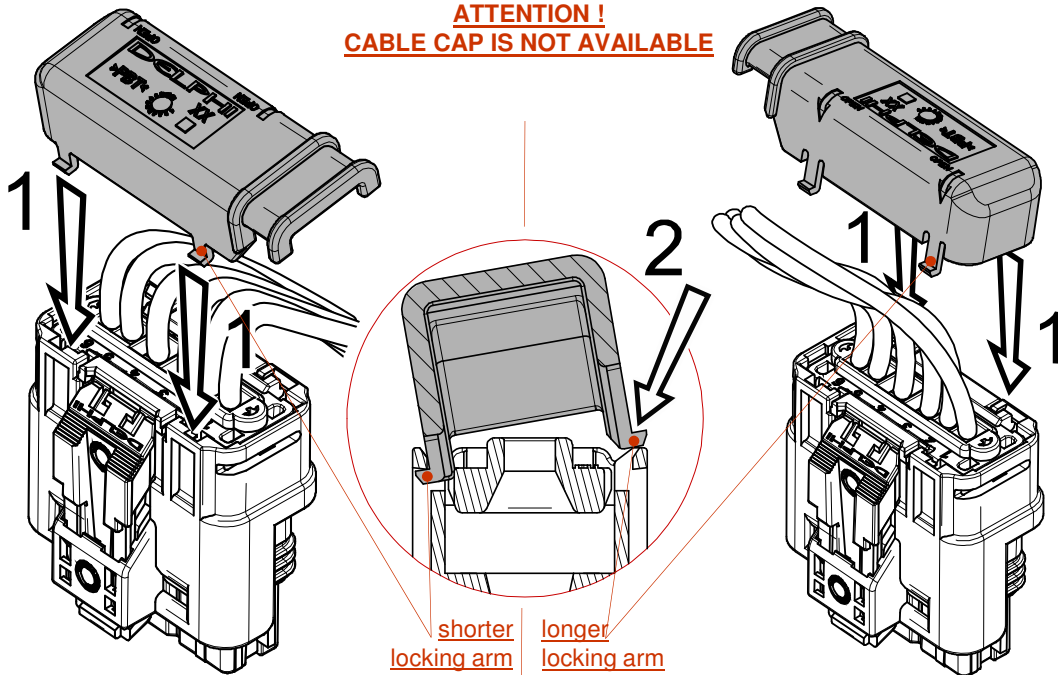

Insert first the shorter locking arm (arrow 1), and press after in the opposite side (arrow 2) to lock the Cable Cap TYPE A

4a

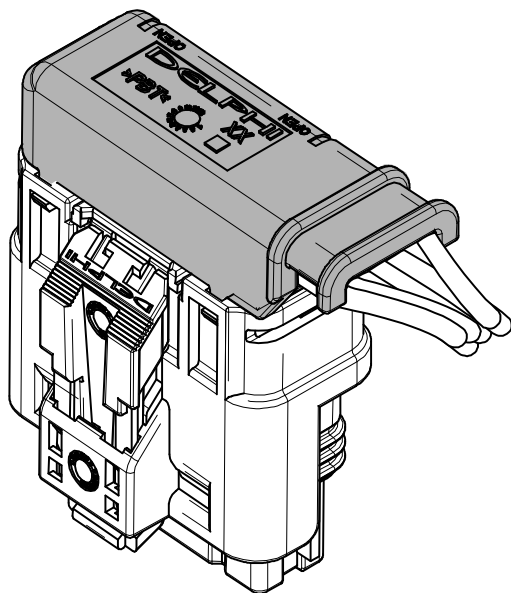

Step completed.

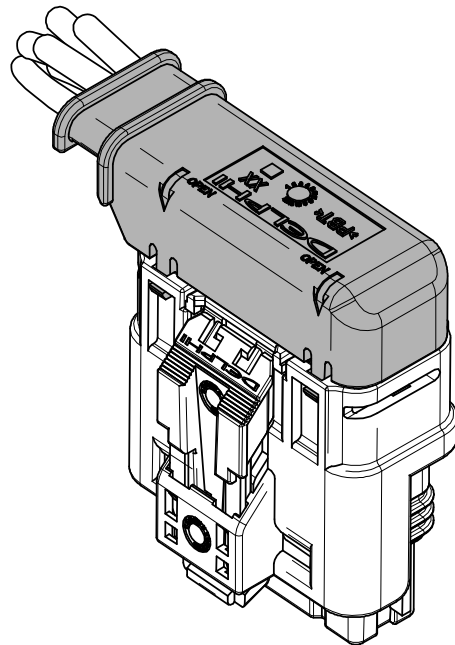

LOCKING CABLE CAP

A
S
E
M
B
L
Y

OPTIONAL (*Cable Cap TYPE B*)

ATTENTION !
CABLE CAP IS NOT AVAILABLE

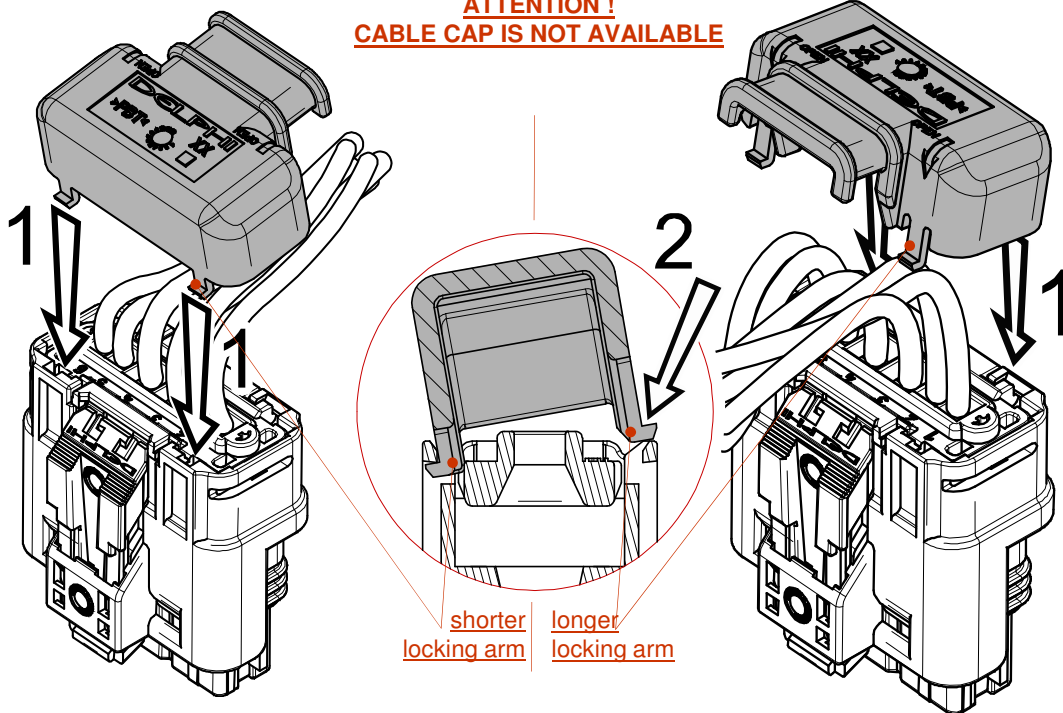

4b

... or *Cable Cap TYPE B*

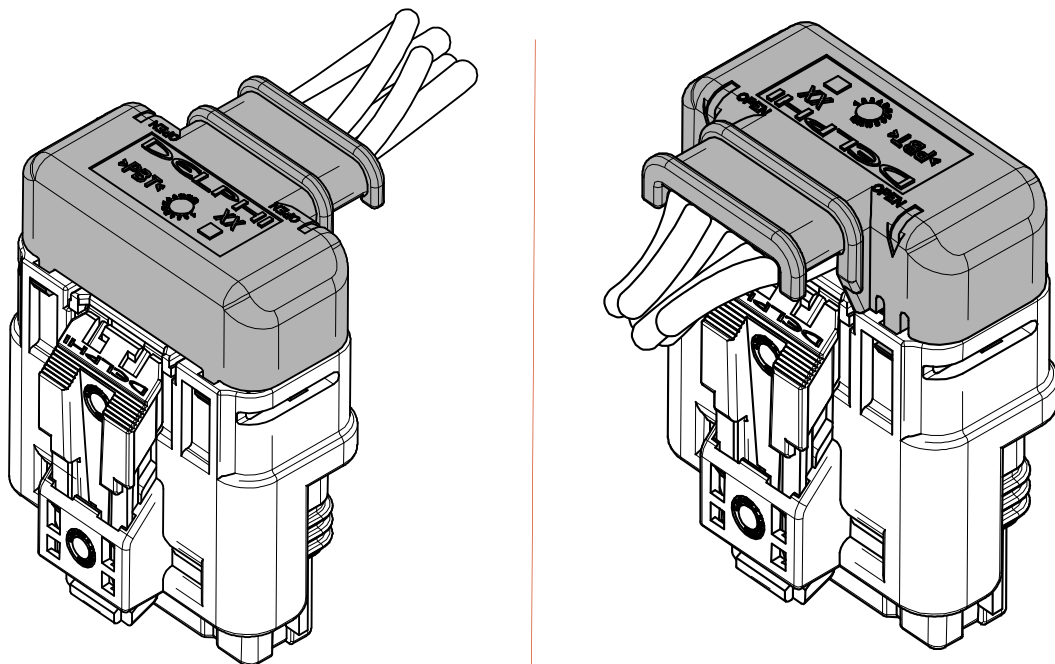

Step completed.

STRAPPING CABLES

A
S
E
M
B
L
Y

OPTIONAL (*Cable Cap TYPE A*)

ATTENTION !
CABLE CAP IS NOT AVAILABLE

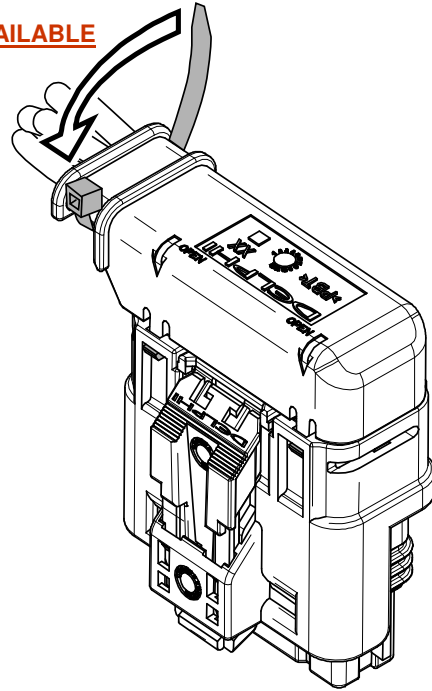
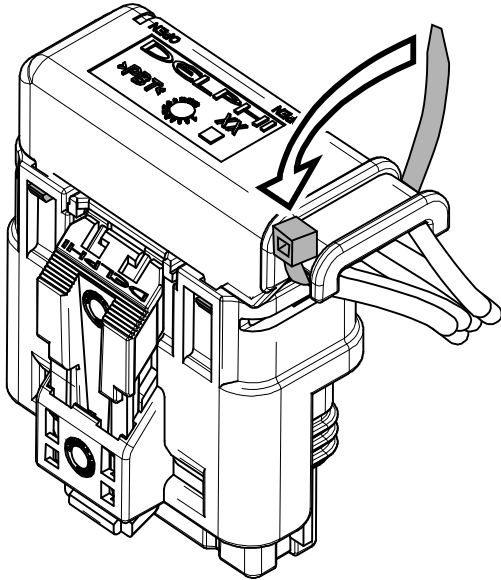

5a

The cables are tightening ...

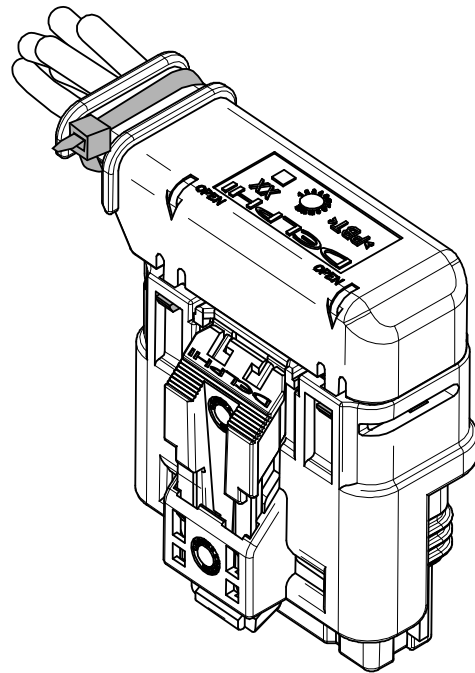
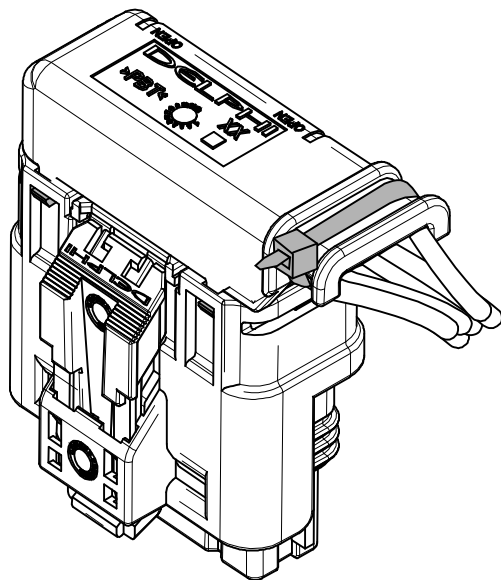

Step completed.

STRAPPING CABLES

A
S
S
E
M
B
L
Y

OPTIONAL (*Cable Cap TYPE B*)

ATTENTION !
CABLE CAP IS NOT AVAILABLE

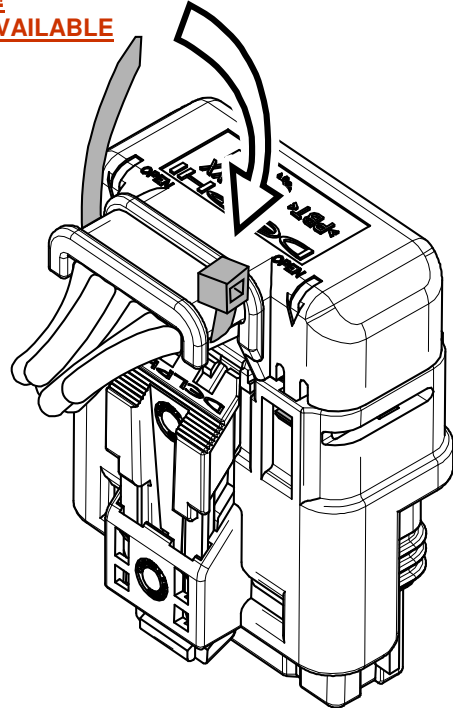
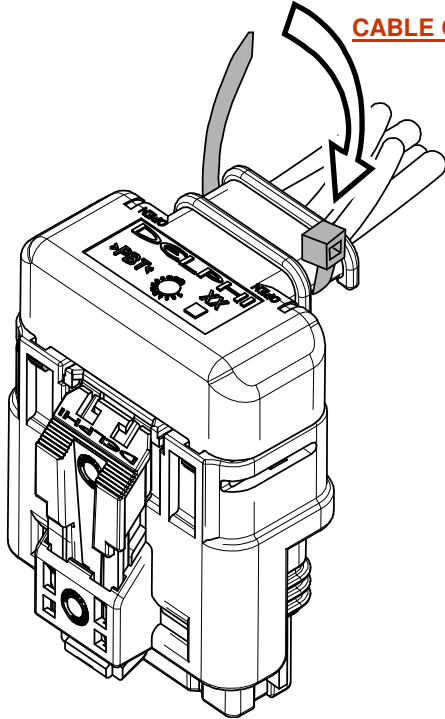

5b

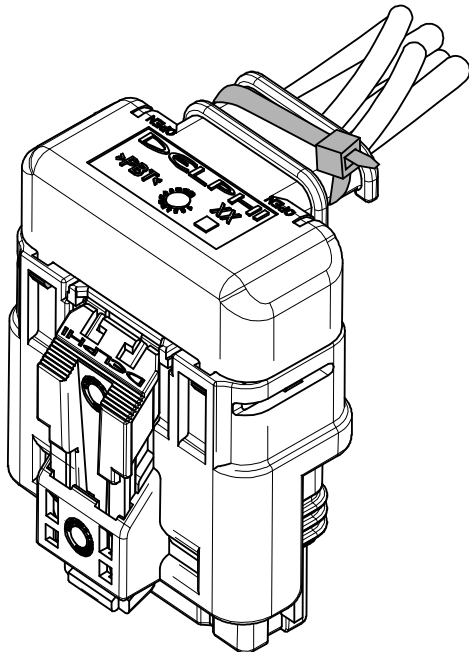

Step completed.

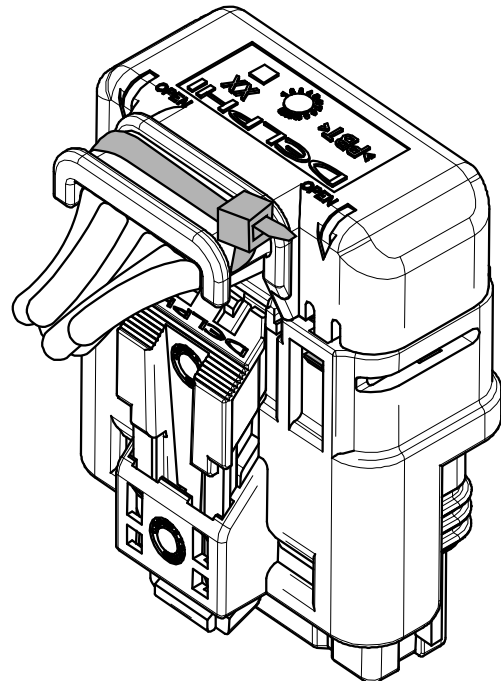

ELECTRICAL TEST

A
S
S
E
M
B
L
Y

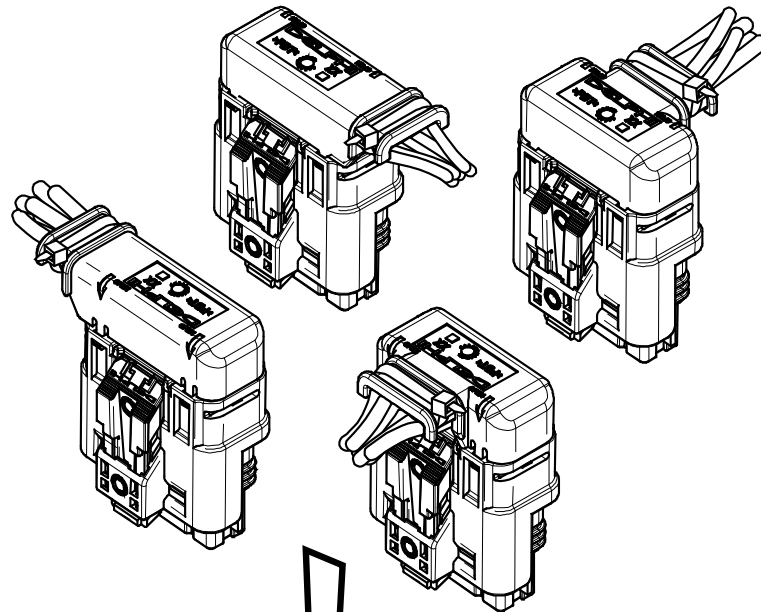

6

Apply the electrical test. Measurement and assembly controls

REQUIREMENTS FOR TESTING CONNECTOR 6-WAY

A
S
S
E
M
B
L
Y

Position	Item	Data
1	Test Probes	
1.1	Position of Test probes	<p>CPA AND CABLE CAP ARE OPTIONAL</p> <p>REFERENCE PLANE</p> <p>TEST PROBE FOR 1.5 TERMINAL</p> <p>TEST PROBE FOR 2.8 TERMINAL</p>
1.2	Head shape of Test probe	Flat head Rectangle
1.3	Head dimensions	<p>Test probe dimensions for 1.5 and 2.8 terminals is 0.6 x 4mm - FLAT HEAD; TOLERANCE +/- 0,02 mm</p>
1.4	Maximum contact force	The maximum Force to 1.5 and 2.8 Terminals is 15 N

REQUIREMENTS FOR TESTING CONNECTOR 6-WAY

ASSEMBLY	Position	Item	Data
	1.5	Position tolerance of terminal cavity of correctly seated terminal	from 23.08 mm (terminal 1.5) to 23.88 mm (terminal 2.8) in reference to the Reference Plane (see position 1.1)
	1.6	Dimension of locked and unlocked terminal	less than 23.08 mm (terminal 1.5) in reference to the Reference Plane (see position 1.1)
	1.7	Design of test probe connection	Sigma test probe
	2	Connector	
	2.1	Coding control	Coding control required. Coding control via mechanical coding in test holder. If version 15458150 (Black) or 15427143 (Violet) is used in the production, a greyscale sensor is needed distinguish the version because the coding is identically.
	2.2	Tightening area and position of connector	<p>The figure contains three technical drawings of a 6-way connector:</p> <ul style="list-style-type: none"> Top View: Shows a rectangular connector with a width of 30.53 ± 0.1 mm. It features four rounded corners with a radius of 4x R 2.6 ± 0.1 mm. The terminal positions are defined by dimensions: 3.33 mm, 4.15 mm, and 2.5 mm from the left edge, and a total width of 13.3 ± 0.1 mm for the terminal area. B-B Section: A cross-section showing the connector's height of 29.725 mm. The terminal cavity width is 29.33 ± 0.15 mm, with a central width of 27.83 ± 0.15 mm and a terminal width of 25.1 ± 0.15 mm. The overall width of the connector body is 30.53 ± 0.2 mm, 32.73 ± 0.2 mm, and 35.9 ± 0.2 mm at different points. A-A Section: A cross-section showing the terminal height of 8.8 ± 0.1 mm. The terminal width is 1.75 ± 0.05 mm, with a gap of 1.7 ± 0.1 mm between terminals. The terminal cavity depth is 7 ± 0.1 mm, and the total height of the terminal area is 9.95 ± 0.1 mm. The overall height of the connector body is 20.6 ± 0.1 mm. The terminal cavity width is 11.5 ± 0.1 mm, with a terminal width of 13.7 ± 0.1 mm and a total width of 17.5 ± 0.1 mm. The terminal cavity depth is 0.6 ± 0.1 mm, and the total depth of the terminal area is 22.3 ± 0.15 mm.
	2.3	Clamping Force	?

REQUIREMENTS FOR TESTING CONNECTOR 6-WAY

A
S
S
E
M
B
L
Y

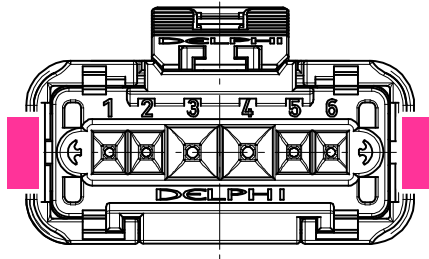
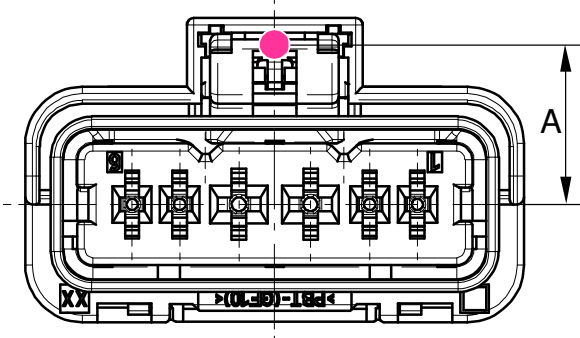
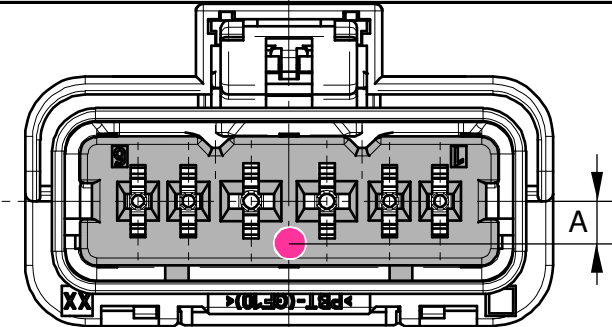
Position	Item	Data
2.4	Position of connector fixing	 <p>The positioning of the connector fixing in the test holder is on the left and right side of the connector on the symmetry middle of the connector. Clamping only on the housing.</p>
2.5	Position of switch probe for connector detection in holder	 <p>The positioning of the connector detection in the test holder symmetry middle of the connector. A = 11,25 mm, Switch Pin Head = Ø 3 mm</p>
3	Additional test	
3.1	Control Secondary Lock (Step1)	 <p>Check on precense and open position of SL. The positioning of the SL detection in the test holder symmetry middle of the connector. A = 2,25 mm, Switch Pin Head = Ø 1 mm</p>
3.1.1	Define maximum force to close SL	15 N < F < 40N
3.1.2	Define maximum travel way to close SL	3,5mm

REQUIREMENTS FOR TESTING CONNECTOR 6-WAY

**A
S
S
E
M
B
L
Y**

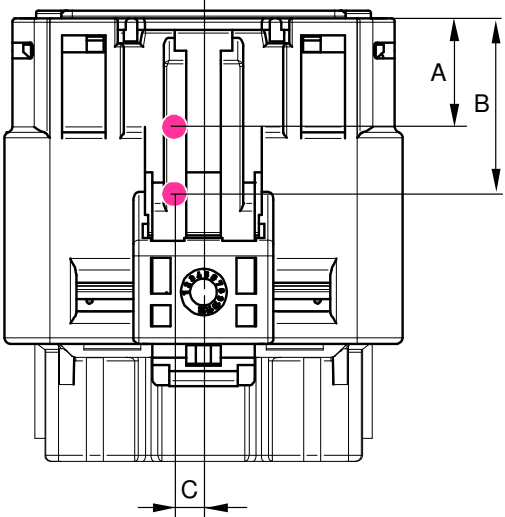
Position	Item	Data
3.1.3	Position of the SL closing mechanism	see page 11
3.1.4	Control Secondary Lock on close (Step5)	The locking position of the PLR (SL) is checked by the end position of the SL closing mechanism
3.2	Leak test	Leak Test required
3.2.1	Test parameter	Test realization = Pressure Nominal Pressure = 300m Bar Limits Good = 200 mBar < P < 500 mBar
3.3	Presence and position check of cable tie	Depend on conditions.
3.4	CPA presence check	Is required when option is assembled.
3.4.1	Position of CPA presence check	 <p>Position in prototype holder (new standard): Symetry middle of connector from top. Point 1 CPA open Point 2 CPA presence A= 13,9 mm B=18,25 mm C=4mm Switch probe head Ø 2 m</p>
4	Test parameter	
4.1	Step 1	Check SL on open
4.2	Step 2	Execute push test
4.3	Step 3	Check connection
4.4	Step 4	Close SL
4.5	Step 5	Control if SL is closed
4.6	Step 6	Execute leak test
4.7	Step 7	Check lock of cable tie
4.8	Step 8 (optional)	Check color of SL to distinguish Black/ Violet SL
4.9	Step 9 (optional)	Check presence and position of CPA
4.10	Step 10 (optional)	Check Cover

Disassembly



Sequence

REMOVING CABLE TIE

OPTIONAL (*Cable Cap TYPE A*)

ATTENTION !
CABLE CAP IS NOT AVAILABLE

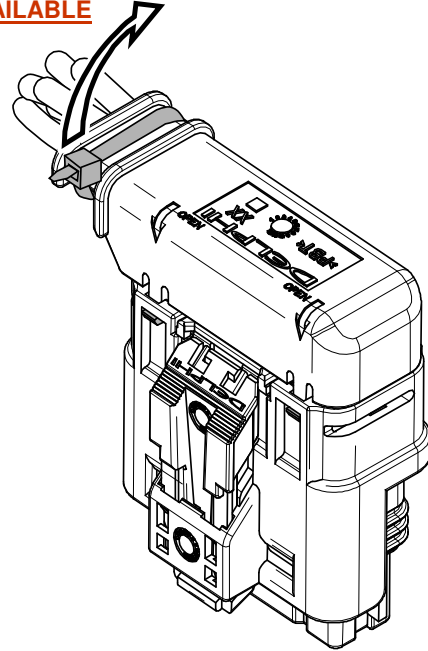
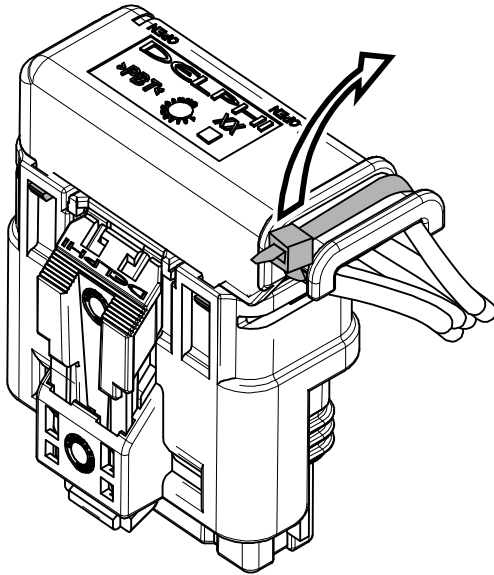

D
I
S
A
S
S
E
M
B
L
Y

D-1a

Remove the plastic tie used to hold the cables

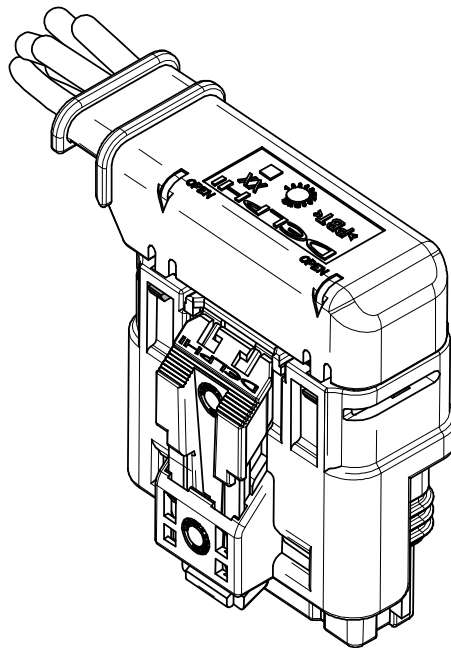
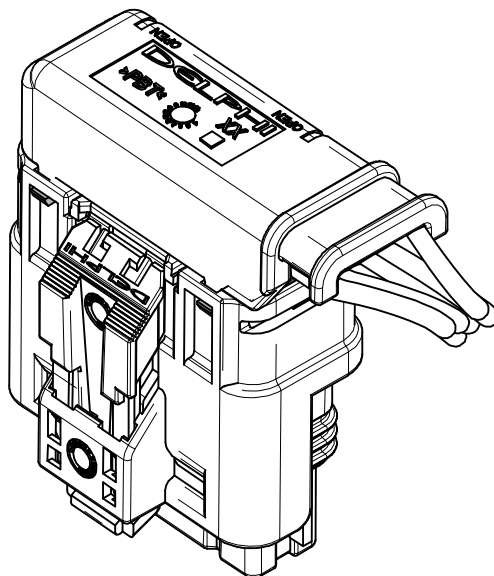

Step completed.

REMOVING CABLE TIE

OPTIONAL (*Cable Cap TYPE B*)

ATTENTION !
CABLE CAP IS NOT AVAILABLE

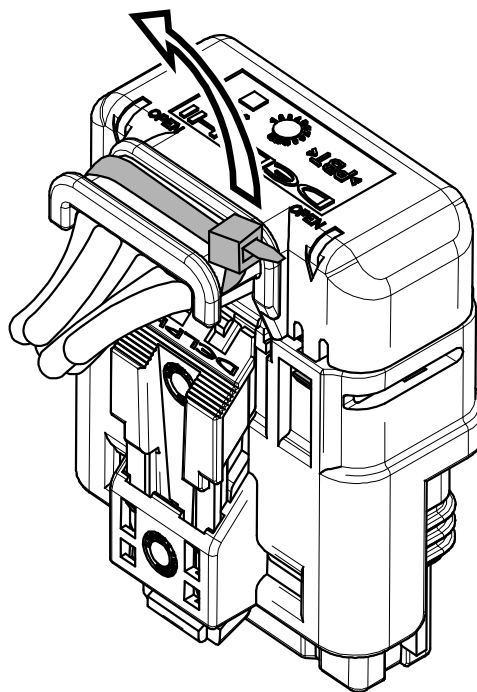
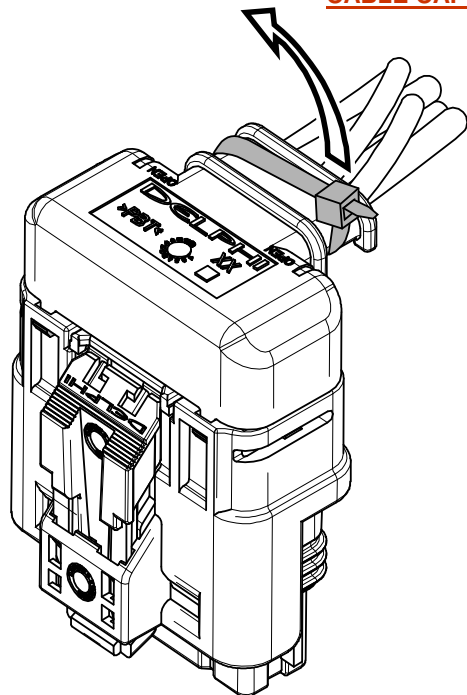

D
I
S
A
S
S
E
M
B
L
Y

D-1b

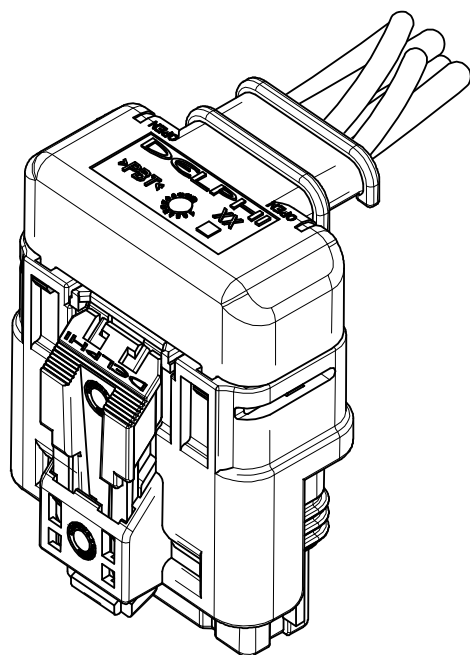

Step completed.

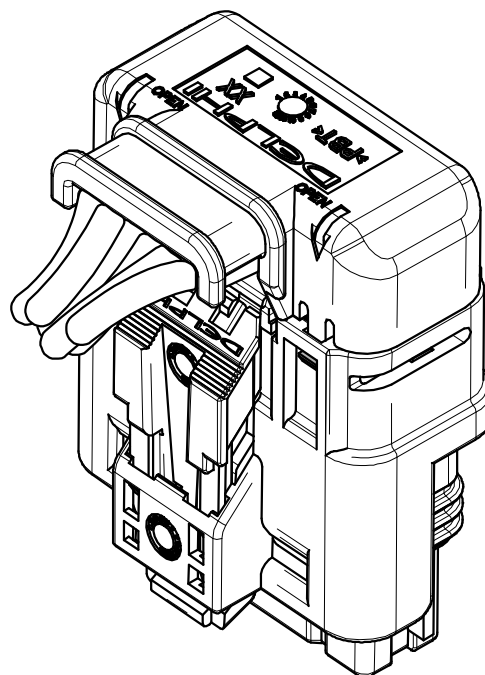

REMOVING CABLE CAP

OPTIONAL (*Cable Cap TYPE A*)

ATTENTION !
CABLE CAP IS NOT AVAILABLE

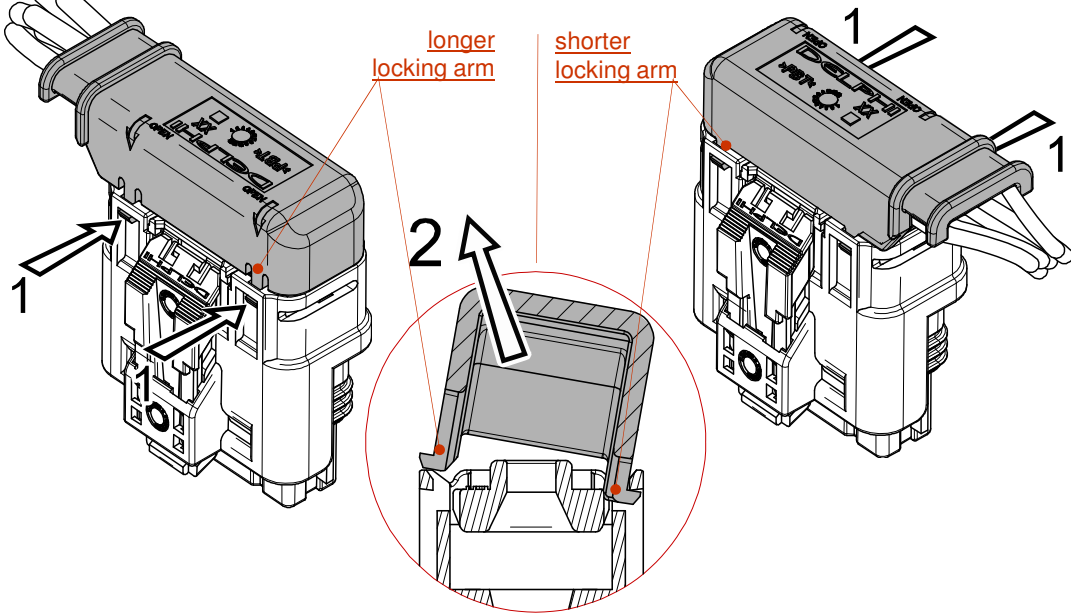

Unlock first longer locking arms side (arrows 1) and then remove (arrow 2) from the Receptacle Housing 6-way Cable Cap TYPE A...

D-2a

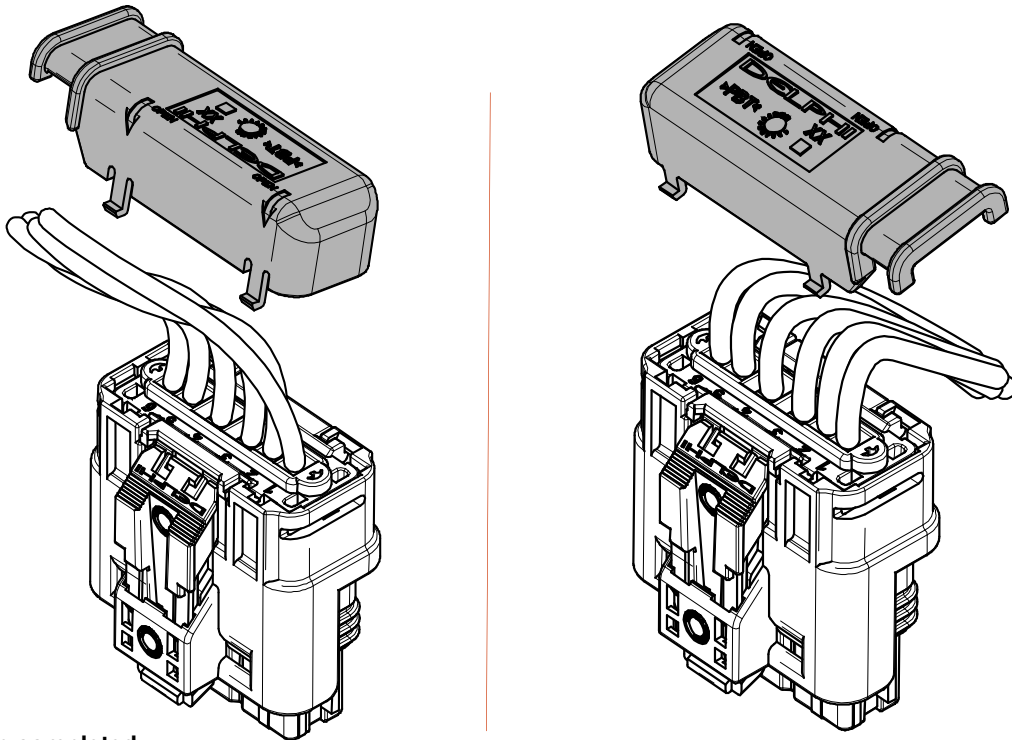

REMOVING CABLE CAP

OPTIONAL (*Cable Cap TYPE B*)

ATTENTION !
CABLE CAP IS NOT AVAILABLE

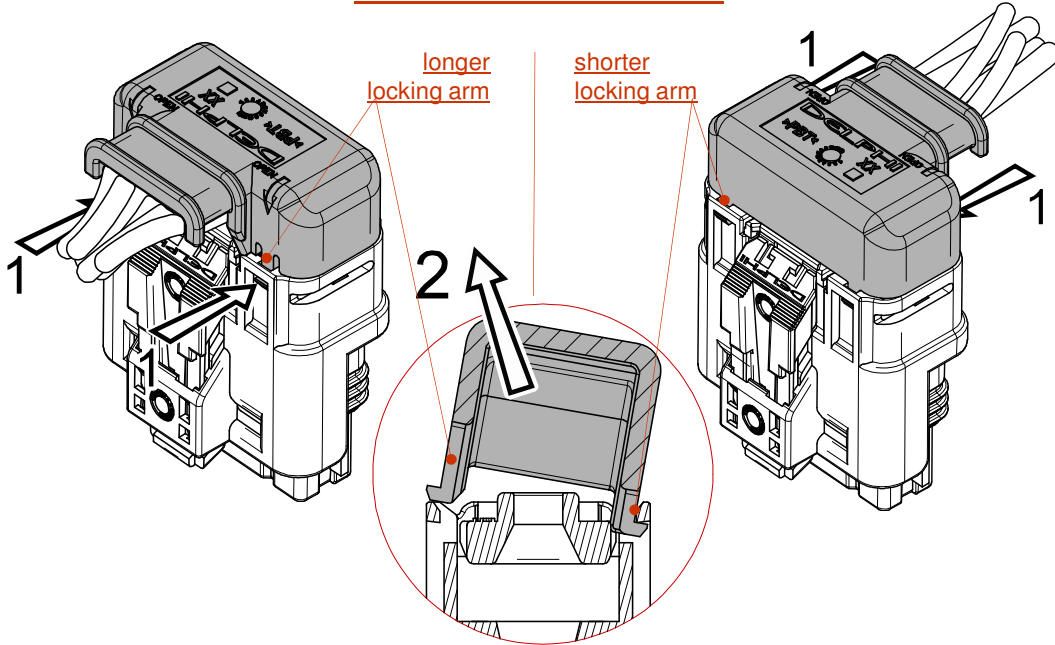

D-2b

... or *Cable Cap TYPE B*.

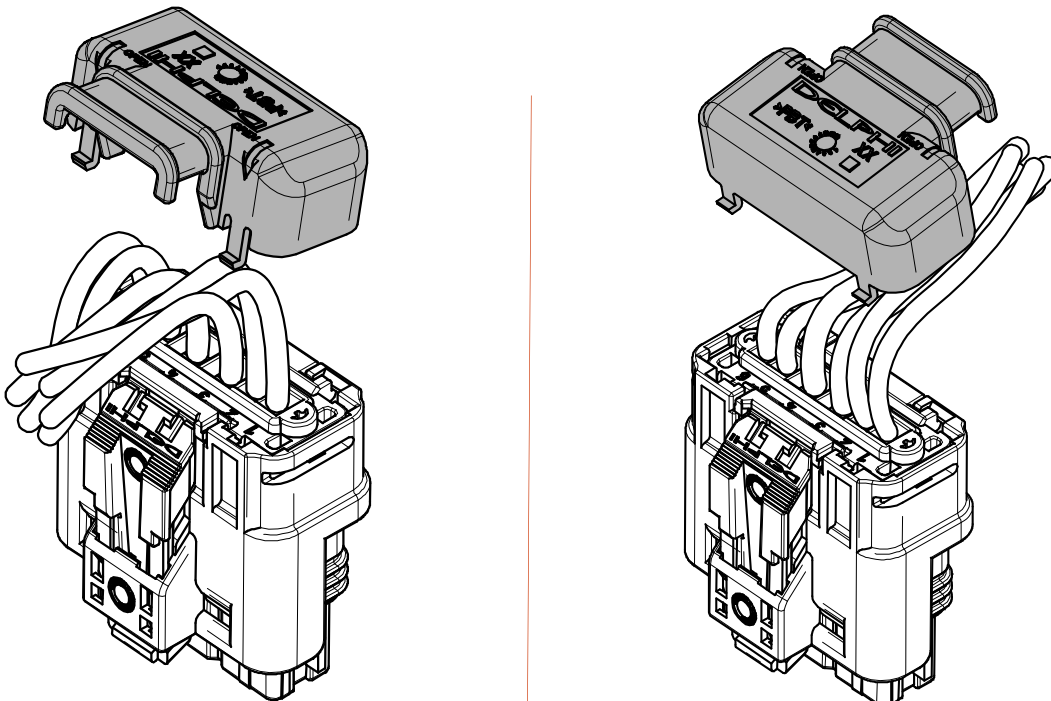

Step completed.

UNLOCKING SL

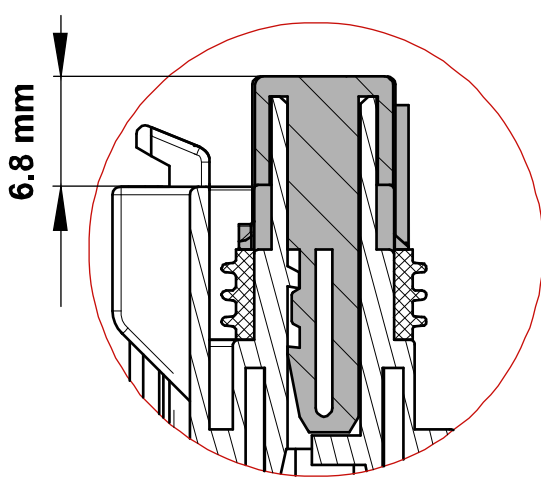

SL in locked position

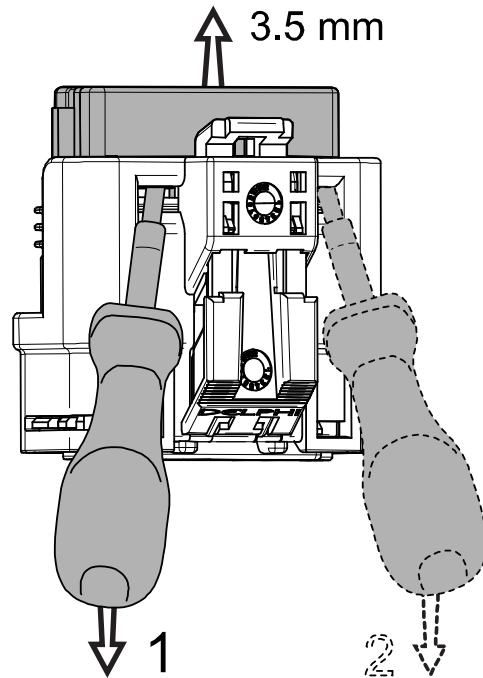

D-3

Using removal tool PN 10804886 unlock SL.

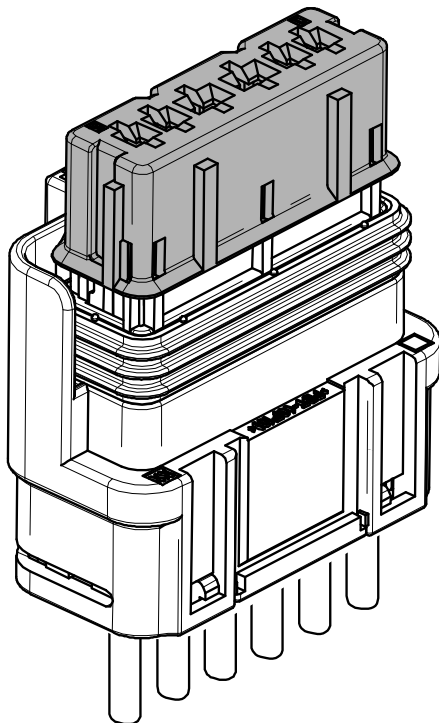

Step completed.

SL in pre-position

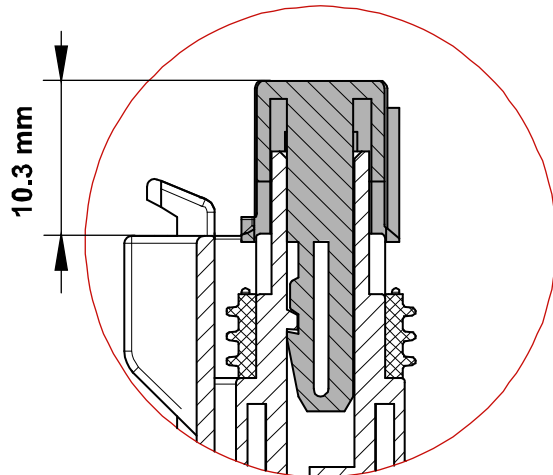

REMOVING TERMINAL 280

D
I
S
A
S
S
E
M
B
L
Y

Primary locking arm of the Terminal

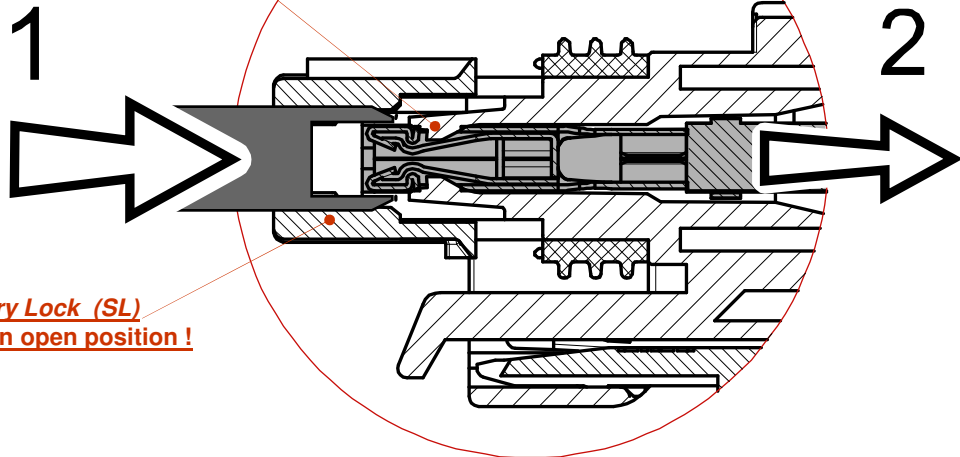

Secondary Lock (SL) must be in open position !

Find the two primary locking arms on the front of the cavity. Insert (operation 1) the hand tool PN 10882549 straight inside the cavity, remove the locking arms in order to unlock the Terminal and pull slowly out the cable to remove the Terminal 280 (operation 2) from the cavity.

ATTENTION: TAKE CARE FOR AVOID CLOSING SL WHILE REMOVING TERMINALS

D-4

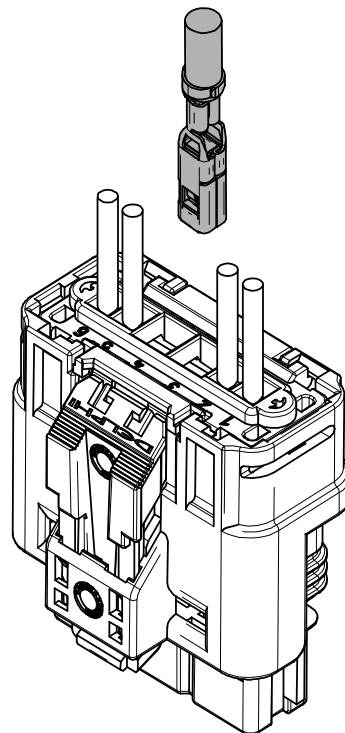
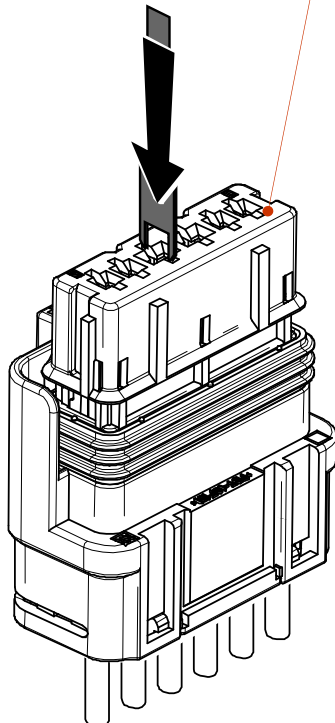

Step completed.

REMOVING TERMINAL 150

Primary locking arm of the Terminal

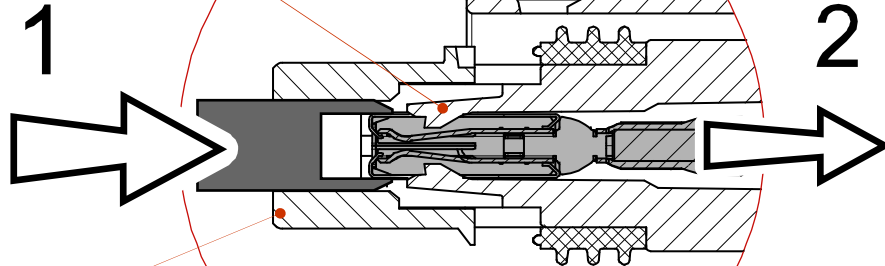

Secondary Lock (SL) must be in open position !

Find the two primary locking arms on the front of the cavity. Insert (operation 1) the hand tool PN 10882549 straight inside the cavity, remove the locking arms in order to unlock the Terminal and pull slowly out the cable to remove the Terminal 280 (operation 2) from the cavity.

ATTENTION: TAKE CARE FOR AVOID CLOSING SL WHILE REMOVING TERMINALS

D-5

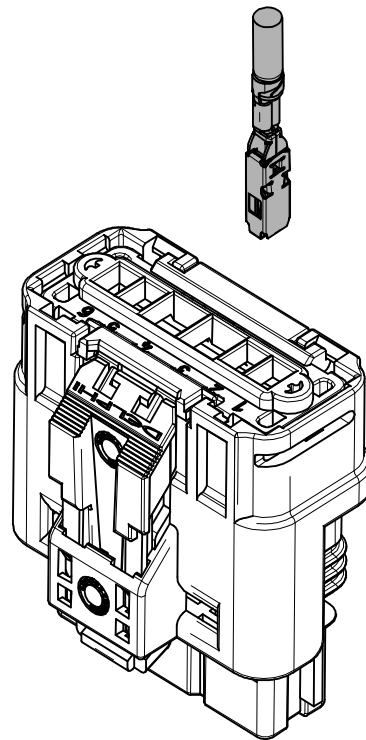
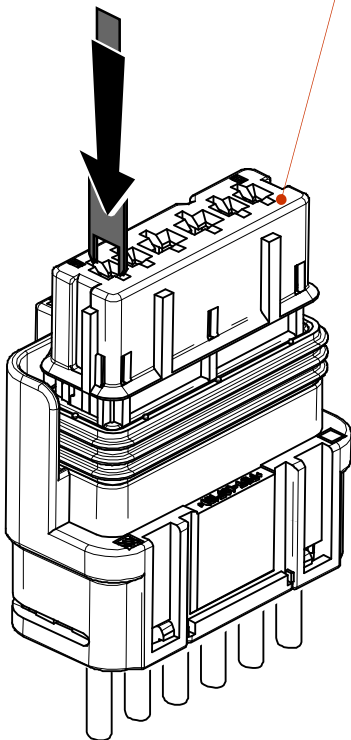

Step completed.

TABLE OF TOOLS

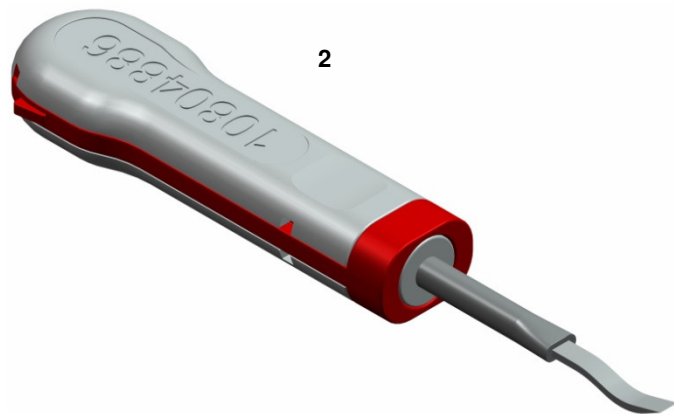
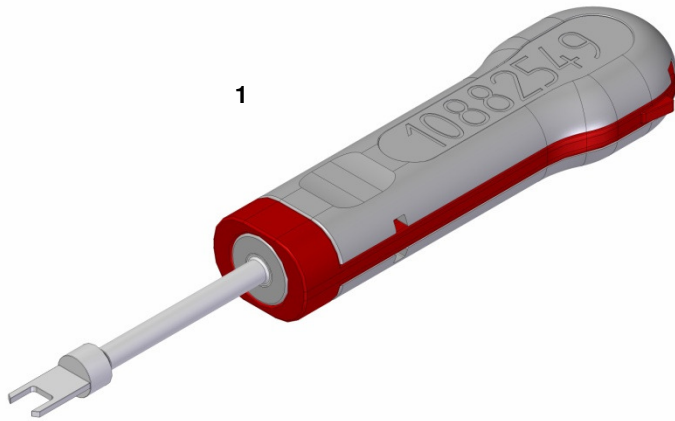

Item	Function	Tool PN.
1	Removal tool for BTS 150/280	10882549
2	Removal tool for SL unlocking	10804886

DRAWINGS OF TOOLS

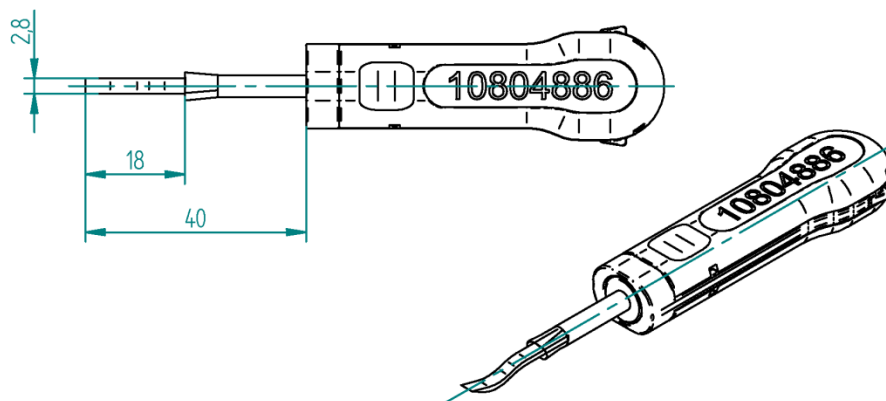
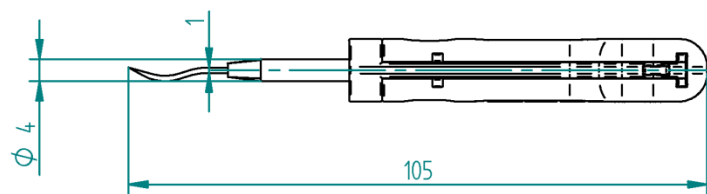
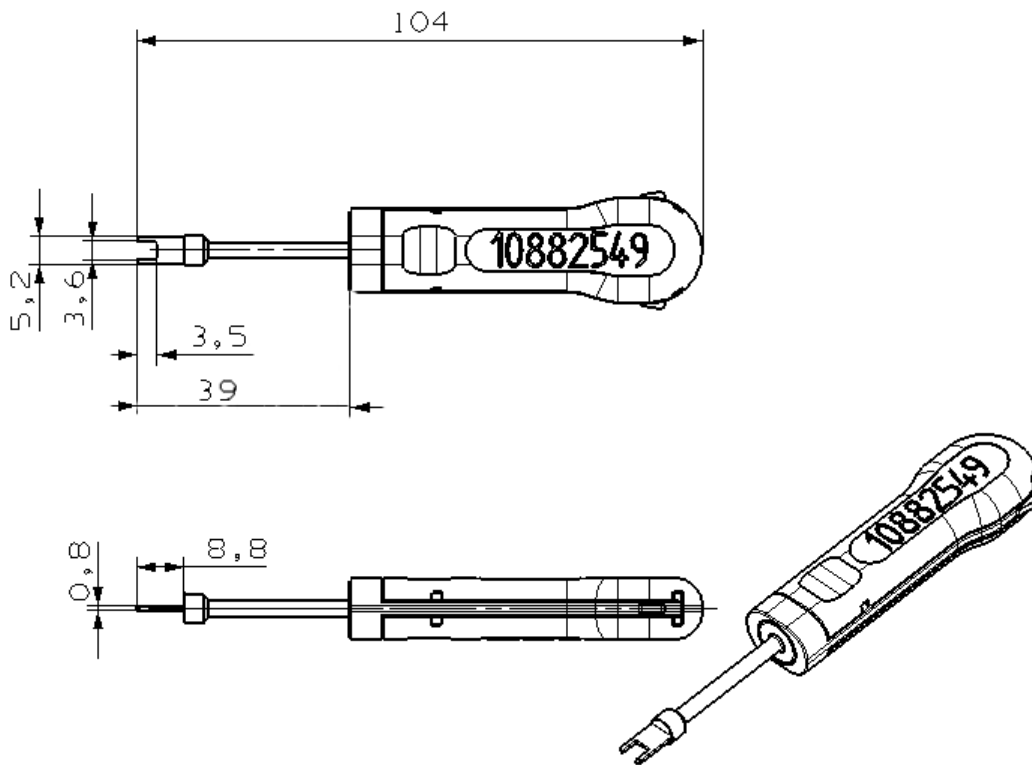

PACKAGING

1) Standard:

- Wrapping in accordance with Standard E73.03.150.G
- 800 parts per carton, GALIA N°12
- Packaging weight: 9,2 Kg
- Carton volume: 380mm x 280mm x 250mm

2) Storage conditions

- Storage temperature: +5 °C to +30 °C
- Storage time: unlimited (consumption according to "first in first out" principle)

3) Handing:

- Do not throw the cartons.

REVISIONS

Revision	Change description	Date
REV 01	Initial release	Mar 24, 2005
REV 02	Updated testing information and added requirements for <i>Connector Family 2-6 way</i> (pages 16 - 20)	Mar 28, 2006
REV 03	- Added new page 9 - CPA delivery status - Added new page 12 - Inserting <i>Cavity Plug</i> - Added new pages 32, 33 - removal tools drawings	Dec 13, 2006
REV04	Connectors 2-, 3-way removed New removal tool PN 10882549 was 10803855	May 01, 2012

Mouser Electronics

Authorized Distributor

Click to View Pricing, Inventory, Delivery & Lifecycle Information:

[Aptiv:](#)

[15414369](#) [15414438](#) [15414435](#) [15414437](#)