

PROJECT NO.	LOC	DIST	REVISIONS					
EGATN07138	A1	-	P	LTR	DESCRIPTION	DATE	DWN	APVD
	A1				SEE E-08-012925	27MAY2008	CA	VB
	A2				SEE E-12-013952	03AUG2012	SK	AK

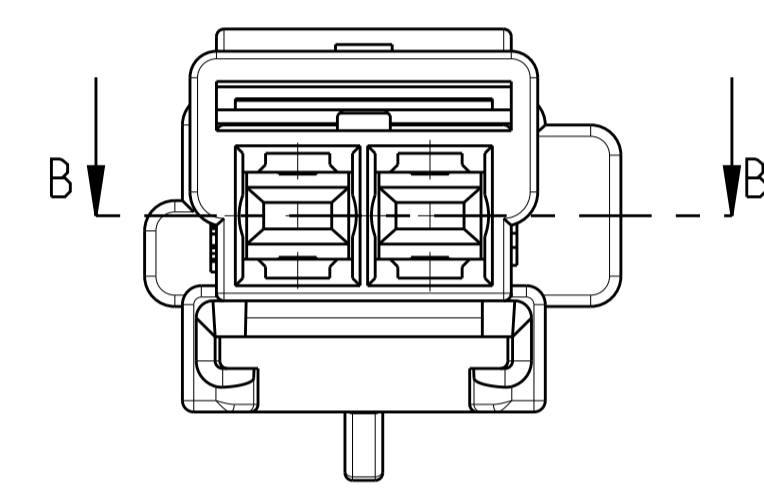

- NOTES
BEMERKUNGEN
- NV NOTE NOT VALID
Bemerkung nicht verwendet
 - 1 ORDER NUMBER
BESTELL-NUMMER
 - 2 REVISION NUMBER
WERKZEUGÄNDERUNGSINDEX
 - 3 MATERIAL MARKING
WERKSTOFFKENNZEICHNUNG
 - NV GM LOGO
GM Logo
 - 5 PRODUCTION DATE
PRODUKTIONSdatum
 - 6 CONTACT CAVITY NUMBER
KONTAKTKAMMERNUMMER
 - 7 TE LOGO
TE Logo
 - 8 PACKAGING: BULK MATERIAL IN CARDBOARD BOX
VERPACKUNG: SCHÜTTGUT IN KARTON
 - 9 TOOL CAVITY MARKING
NESTMARKIERUNG
 - 10 SLOT FOR GM 13257300 (ZUH 360)
Aufnahme fuer GM 13257300 (ZUH 360)

B-B

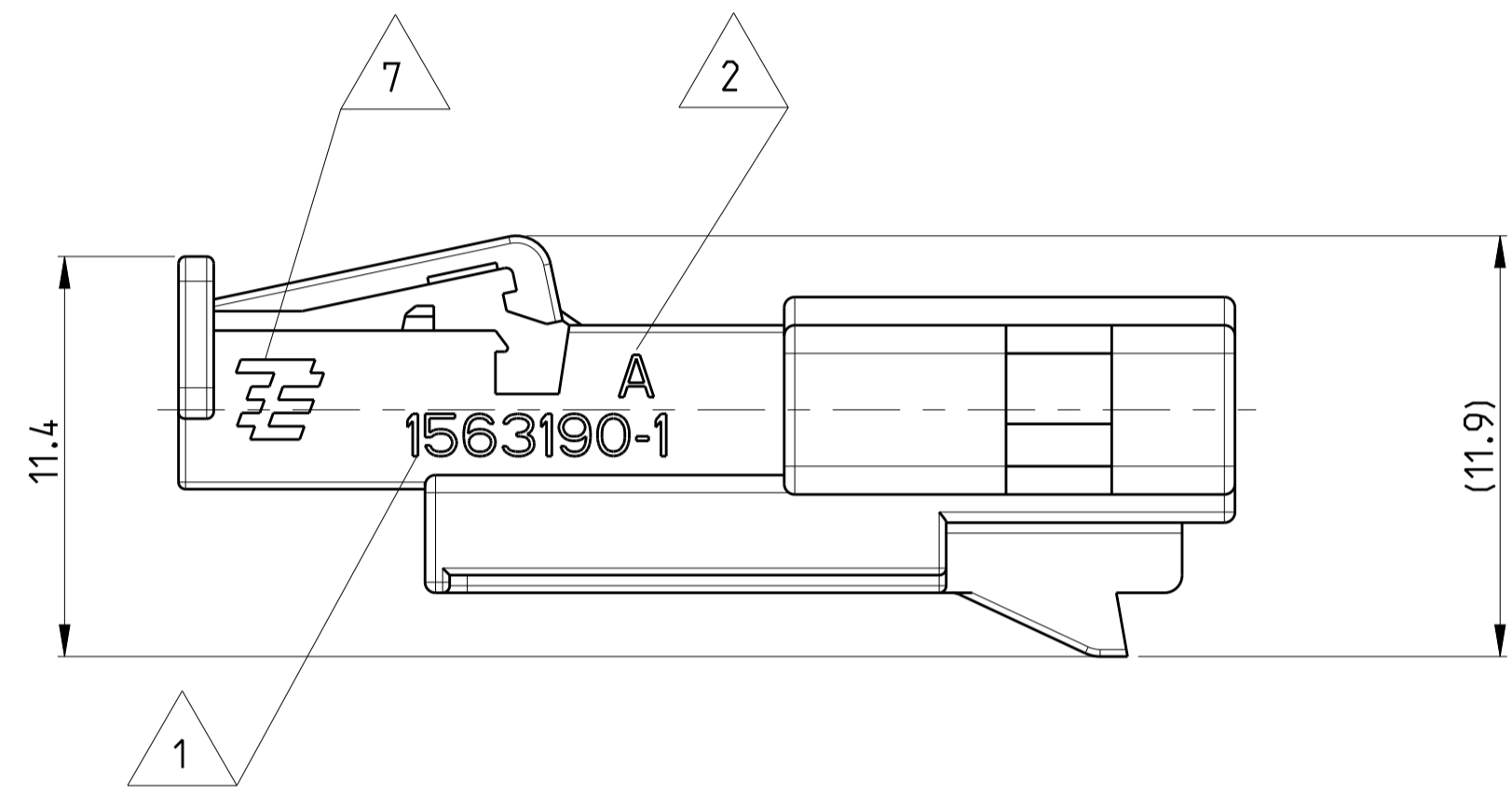
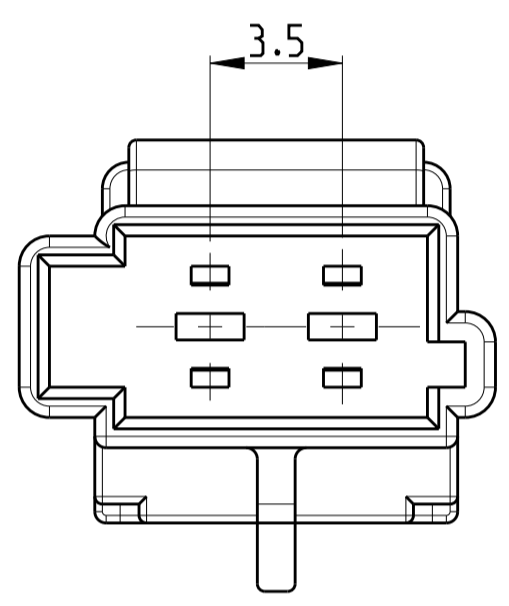
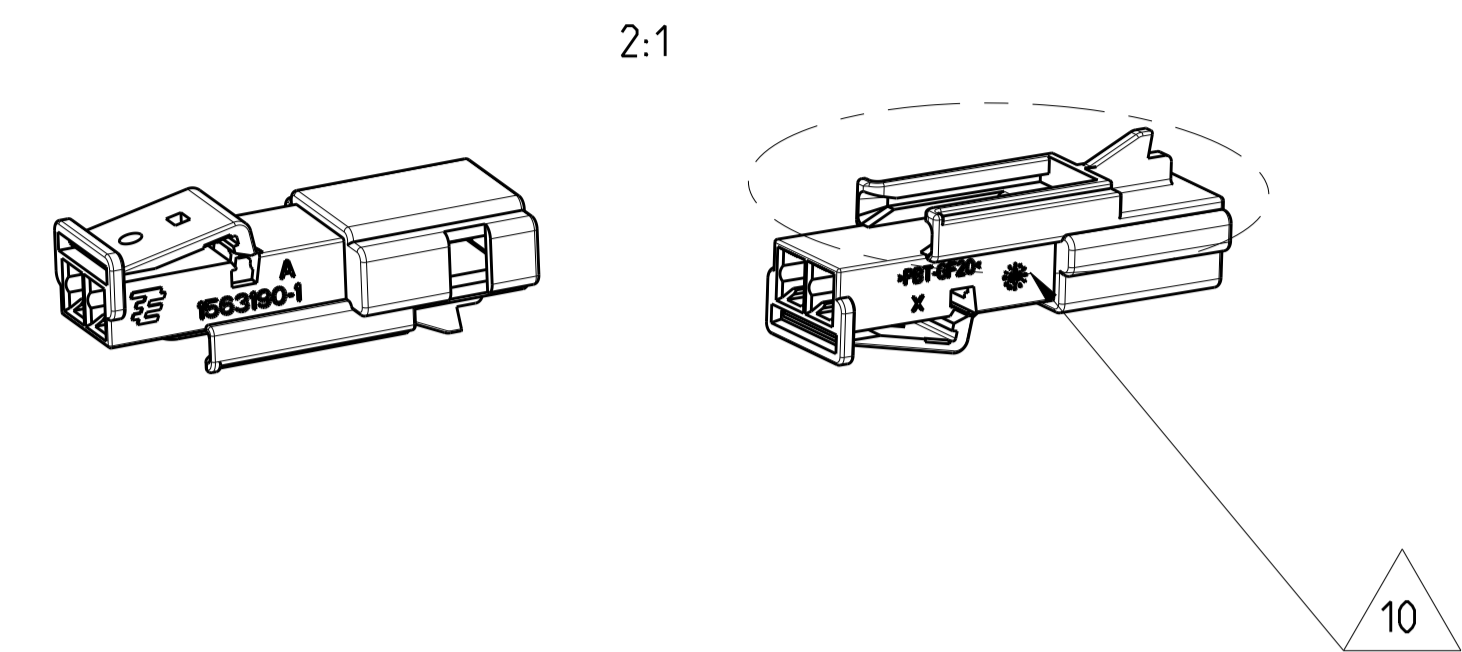
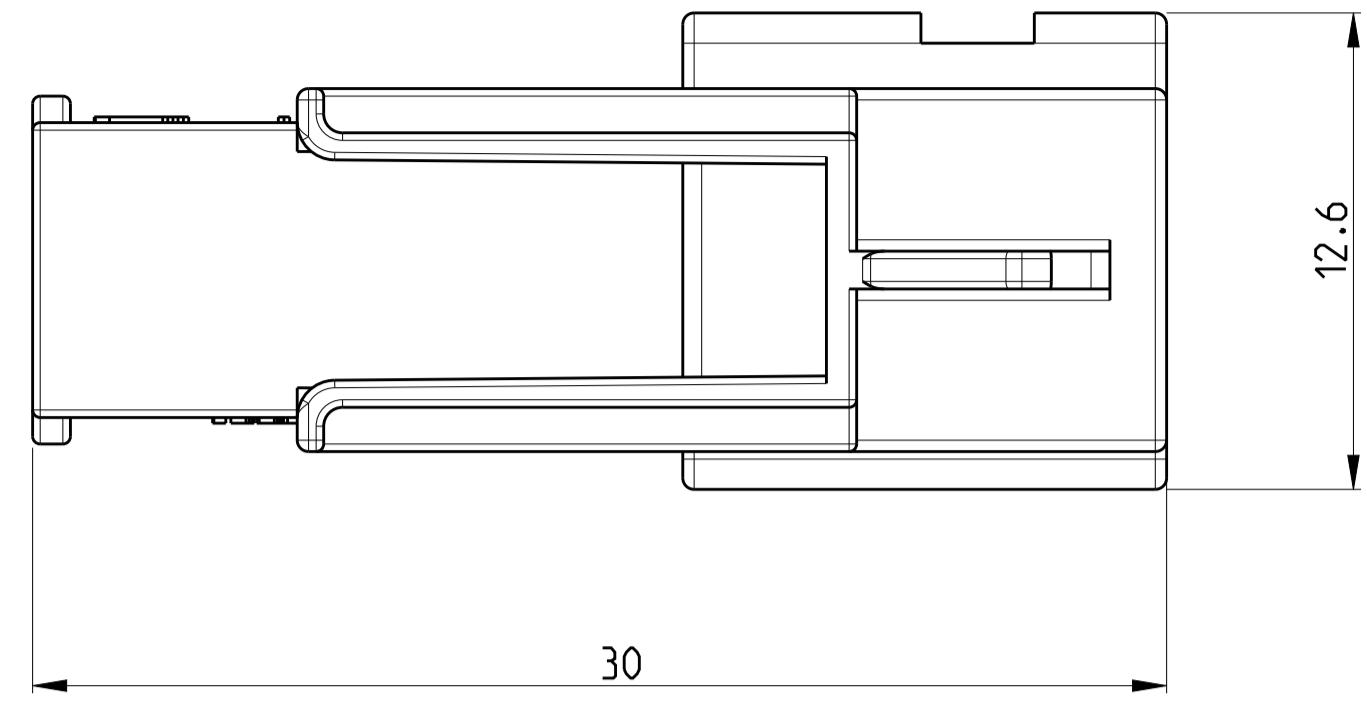
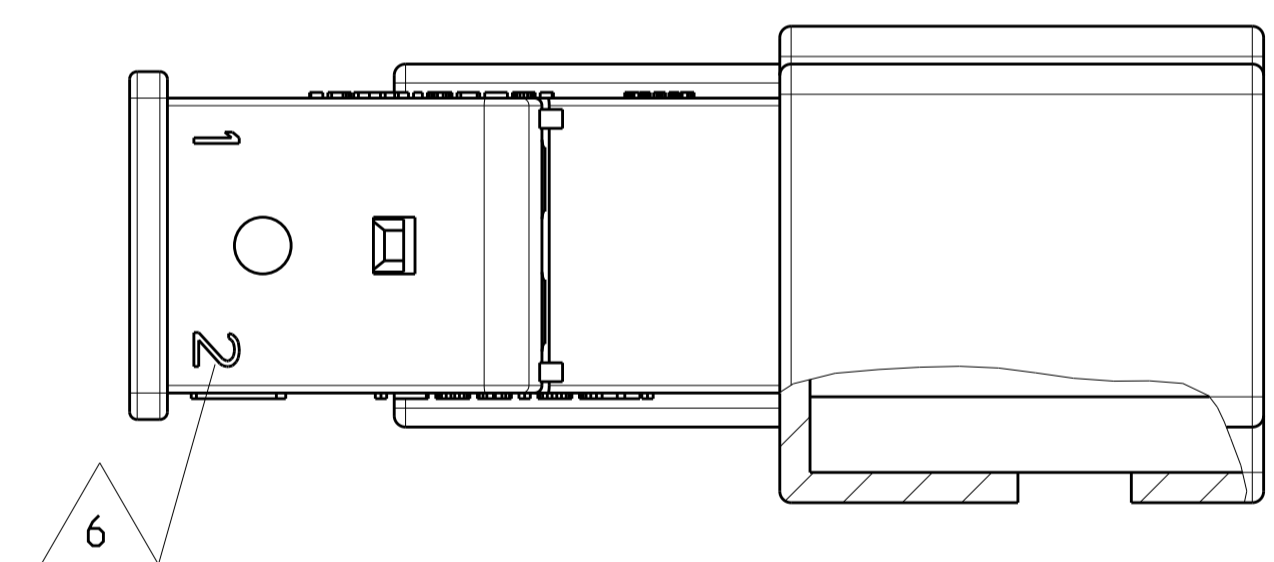

CODING A

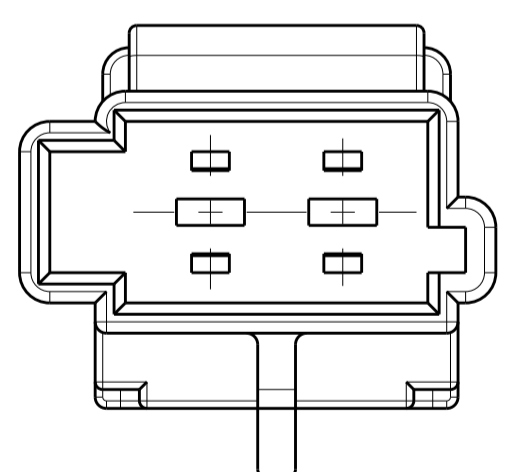

CODING B

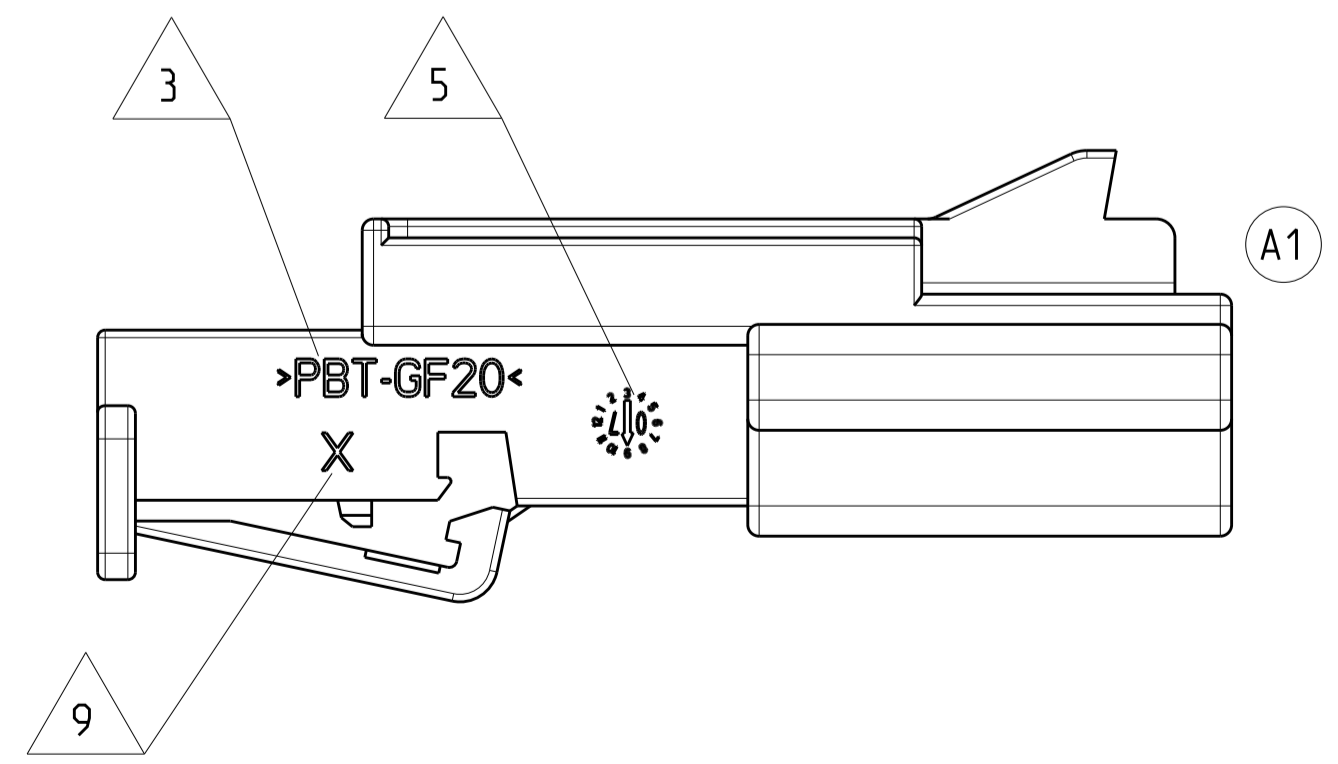
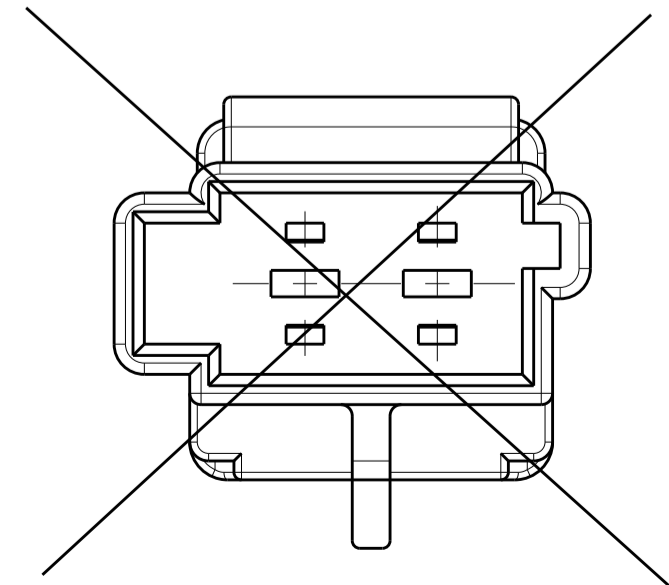

A1	0-1452140-3	2 Pos. MT2, Rec-Hsg.
	1-0962580-1	2 Pos. MT2, Rec-Hsg.
	0-1563189-1	2 Pos. MT2, Rec-Hsg.
	TE BESTELL-NR. TE ORDER NO.	BENENNUNG DESCRIPTION
	COUNTERPARTS GEGENSTECKER	

A2	0-1241846-2	1.5	CuFe 2	PRETINNED
	0-0964267-2	0.5-1.0	CuFe 2	PRETINNED
	0-0964265-2	0.35-0.5	CuFe 2	PRETINNED
	TE ORDER NO STRIP FORM	WIRE RANGE MM ²	MATERIAL	FINISH
RRECOMMENDED CONTACT SYSTEM: MICRO TIMER 2 TYPE A; UNSEALED FOR CABLE INSULATION TYPE FLR ACC. DIN 72551 / ISO 6722 MAX. WIRE SIZE 1.5mm ² MAX. CABLE INSULATION CRIMP DIAMETER 2.9mm FOR CABLE INSULATION TYPE TXL ACC. SAE J1128 MAX. WIRE SIZE 1.0mm ² OR MAX AWG 18 THE USE OF OTHER CABLE TYPES MUST BE CHECKED IN ANY INDIVIDUAL CASE!				

-	0-1563190-2	A	2 Pos. TAB 1.6x0.6. TAB-Hsg. CODB	hbd	PBT-GF20	1.3	1
19179872	0-1563190-1	A	2 Pos. TAB 1.6x0.6. TAB-Hsg. CODA		BLACK	PBT-GF20	1.3
CUSTOMER PART NO	PART NO	REV	DESCRIPTION		COLOR	MATERIAL	WEIGHT [g]
							ITEM NO

THIS DRAWING IS A CONTROLLED DOCUMENT. DWN C. Anghel 29 JUN 2007
 CHK A. Ketteler 29 JUN 2007

DIMENSIONS: mm
 TOLERANCES UNLESS OTHERWISE SPECIFIED:
 0 PLC ±0.3
 1 PLC ±0.3
 2 PLC ±0.3
 3 PLC ±0.3
 4 PLC ±0.3
 ANGLES ±°
 FINISH ±μm

MATERIAL: -

PRODUCT SPEC: 108-94.118
 APPLICATION SPEC: 116-18901

NAME: 2 Pos. 1.6x0.6. TAB Hsg.
 SIZE: A1
 CAGE CODE: 00779
 DRAWING NO: C=1563190

RESTRICTED TO: -

SCALE: 5:1 SHEET 1 OF 1 REV: A2

Mouser Electronics

Authorized Distributor

Click to View Pricing, Inventory, Delivery & Lifecycle Information:

[TE Connectivity:](#)

[1563190-1](#)