

REVISIONS					
P	LTR	DESCRIPTION	DATE	DWN	APVD
	AA	REVISED PER ECO-14-015277	14FEB2015	NK	DR
	AA1	REVISED PER ECO-17-008114	05JUN2018	RS	DR

<b>AMP</b> WIRE RANGE	E13288 Listed	LR7189 Certified
22-16 AWG SOLID OR STRANDED	22-16 AWG SOLID OR STRANDED	22-16 AWG SOLID OR STRANDED

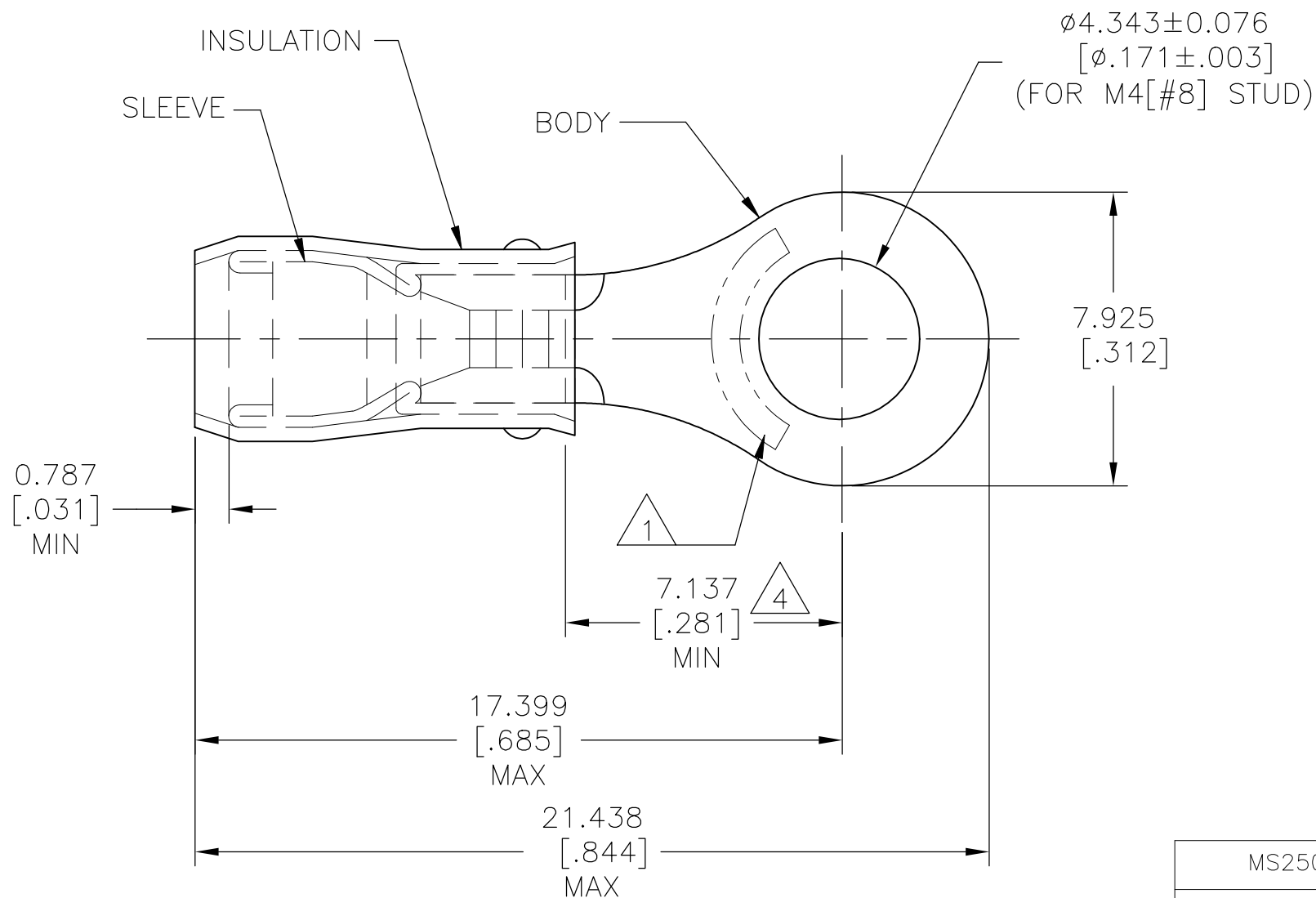

- 1 STAMP AMP 22-18\* APPROX AS SHOWN  
22-16 TERMINALS ARE STAMPED 22-18 IN  
ACCORDANCE WITH MILITARY SPEC SAE AS7928  
COMMERCIAL WIRE RANGE IS 22-16.
- 2 WIRE INSULATION DIA: 2.032-3.175[.080-.125].
- 3 BODY MATERIAL THK: 0.787±0.051[.031±.002].
- 4 APPLIES FROM EDGE OF METAL WIRE BARREL TO  
CENTER OF STUD HOLE.

MS25036-149 CLASS 2	5000	ON TAPE, REEL	1-320551-1
MS25036-149 CLASS 1 & 2	1000	LOOSE PIECE	320551
MILITARY P/N AND CLASS	QUANTITY	PACKAGE TYPE	PART NO

<b>AMP INCORPORATED CUSTOMER SERVICE SYSTEMS</b>		MAX RECOMMENDED OPERATING TEMPERATURE: 105°C[221°F]
FOR ADDITIONAL PRODUCT INFORMATION OR COPIES OF DRAWINGS AND TECHNICAL DOCUMENTS	PRODUCT INFORMATION CENTER 1-800-522-6752	VOLTAGE RATING: 300 V MAX
FOR APPLICATION TOOLING INFORMATION	TOOLING ASSISTANCE CENTER 1-800-722-1111	CIRCULAR MIL AREA: 0.26-1.65mm <sup>2</sup> [509-3,260] CIR MILS SOLID OR STRANDED
FOR ORDER ENTRY	1-800-526-5142	

THIS DRAWING IS A CONTROLLED DOCUMENT.		DWN DK SCHRUM 9/8/93	TE Connectivity Ltd.	
DIMENSIONS: mm [INCHES]		CHK RE HERSEY 9/8/93		
		TOLERANCES UNLESS OTHERWISE SPECIFIED:		APVD ML ELLIS 9/8/93
		0 PLC ± - 1 PLC ± - 2 PLC ± - 3 PLC ± 0.127[.005] 4 PLC ± - ± - ANGLES ± -		NAME UL 486A-B
MATERIAL BODY & SLEEVE COPPER PER ASTM B-152 INSULATION: NYLON		FINISH BODY & SLEEVE TIN PLATE PER ASTM B545 INSULATION: COLOR-RED		PRODUCT SPEC 114-2157
CUSTOMER DRAWING		WEIGHT -	SIZE A3	CAGE CODE 00779
		DRAWING NO C-320551		RESTRICTED TO -
		SCALE NTS		SHEET 1 OF 2
		REV AA1		

P	LTR	DESCRIPTION	DATE	DWN	APVD
-	-	SEE SHEET 1	-	-	-

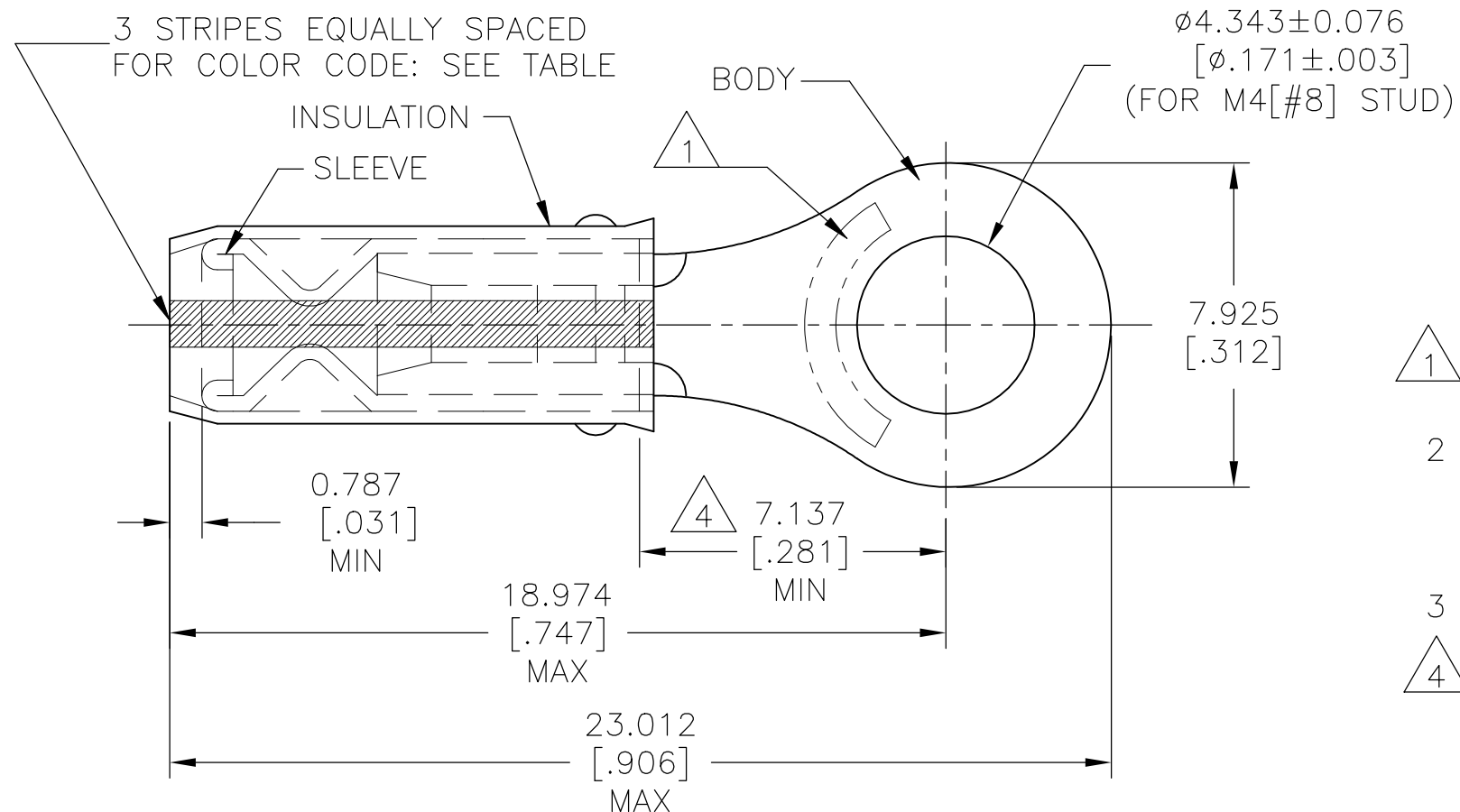

**AMP**  
WIRE RANGE

---

SEE TABLE  
STRANDED

- 1 STAMP AMP APPROX AS SHOWN SEE TABLE BELOW.
- 2 WIRE INSULATION DIA: 0.965–2.794[.038–.110] FOR 22 AWG  
1.168–2.794[.046–.110] FOR 20 AWG  
1.422–2.794[.056–.110] FOR 18 AWG.
- 3 BODY MATERIAL THK: 0.787±0.051[.031±.002].
- 4 APPLIES FROM EDGE OF METAL WIRE BARREL TO CENTER OF STUD HOLE.

-	RED	20*	20	100	LOOSE PIECE, BOX	8-320551-1
M7928/1-32 CLASS 2	WHITE	18*	18	5000	ON TAPE, REEL	1-320551-8
M7928/1-32 CLASS 1 & 2	WHITE	18*	18	1000	LOOSE PIECE	1-320551-4
M7928/1-23 CLASS 1 & 2	RED	20*	20	1000	LOOSE PIECE	1-320551-3
M7928/1-14 CLASS 1 & 2	GREEN	22*	22	1000	LOOSE PIECE	1-320551-2
MILITARY P/N AND CLASS	STRIPE COLOR	1 STAMPING	WIRE SIZE	QUANTITY	PACKAGE TYPE	PART NO

**AMP INCORPORATED  
CUSTOMER SERVICE SYSTEMS**

MAX RECOMMENDED OPERATING  
TEMPERATURE:  
105°C[221°F]

VOLTAGE RATING: 300 V MAX

WIRE RANGE:	CIRC MIL AREA:
22	0.38mm <sup>2</sup> [754]
20	0.60mm <sup>2</sup> [1,186]
18	0.96mm <sup>2</sup> [1,900]

STRANDED

FOR ADDITIONAL  
PRODUCT INFORMATION OR  
COPIES OF DRAWINGS  
AND TECHNICAL DOCUMENTS

PRODUCT INFORMATION CENTER  
1-800-522-6752

FOR APPLICATION  
TOOLING ASSISTANCE CENTER

TOOLING INFORMATION  
1-800-722-1111

FOR ORDER ENTRY  
1-800-526-5142

THIS DRAWING IS A CONTROLLED DOCUMENT.

DIMENSIONS:  
mm [INCHES]

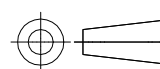

TOLERANCES UNLESS  
OTHERWISE SPECIFIED:

0 PLC	± -
1 PLC	± -
2 PLC	± -
3 PLC	± 0.127[.005]
4 PLC	± -
ANGLES	± -

MATERIAL  
BODY & SLEEVE  
COPPER PER ASTM B-152  
INSULATION: NYLON

FINISH  
BODY & SLEEVE  
TIN PLATE  
PER ASTM B545  
INSULATION: COLOR-RED

DWN  
DK SCHRUM 9/8/93

CHK  
RE HERSEY 9/8/93

APVD  
ML ELLIS 9/8/93

PRODUCT SPEC

APPLICATION SPEC

NOT AVAILABLE

WEIGHT

-

CUSTOMER DRAWING

**STE** TE Connectivity Ltd.

NAME  
TERMINAL, RING TONGUE, I.R.,  
PIDG™ WIRE SIZE, 22-16 AWG

SIZE CAGE CODE DRAWING NO RESTRICTED TO

A3 00779 C-320551

SCALE NTS SHEET 2 OF 2 REV AA1