

Sep.1.2020 Copyright 2020 HIROSE ELECTRIC CO., LTD. All Rights Reserved.
In case of consideration for using Automotive equipment / device which demand high reliability, kindly contact our sales window correspondents.

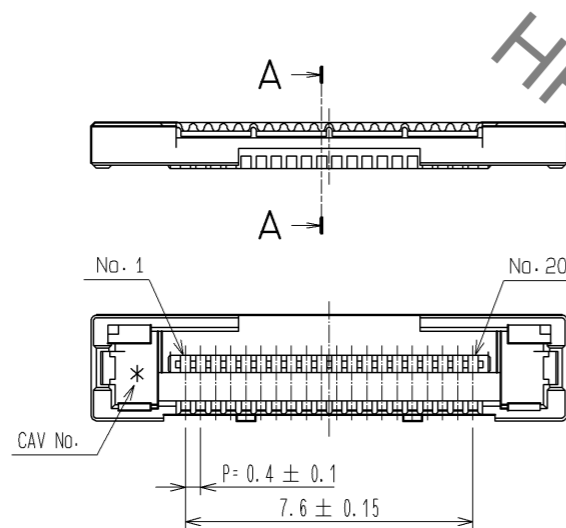

RECOMMENDED CABLE SUBASSEMBLY

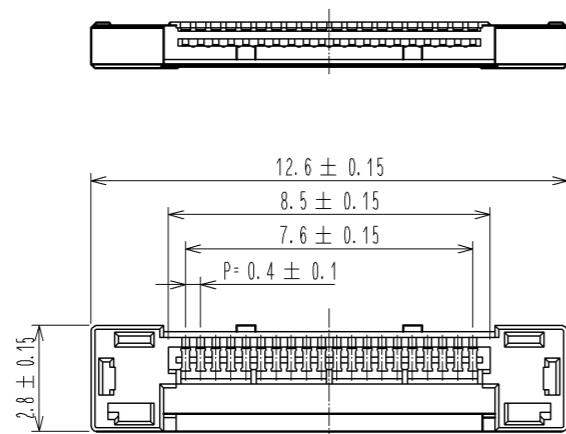
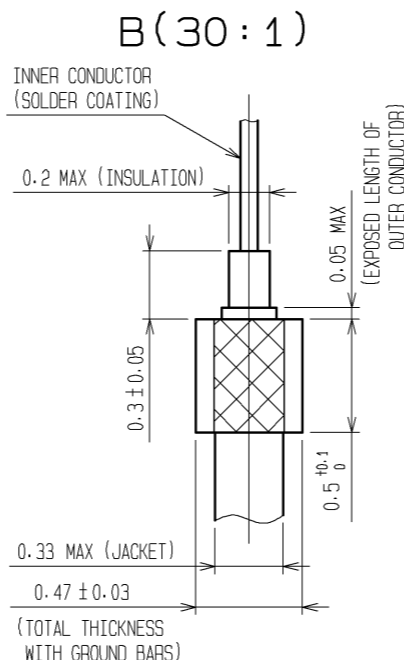
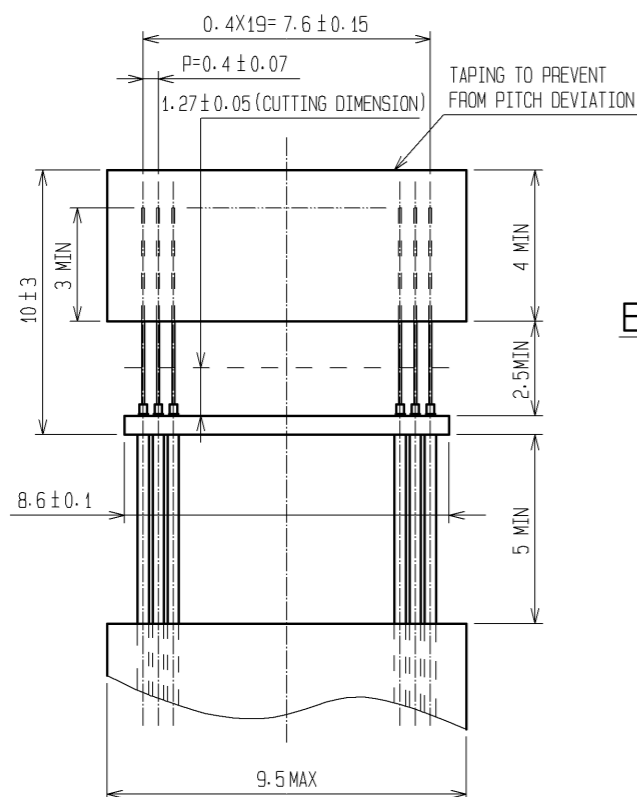

A-A (30:1)

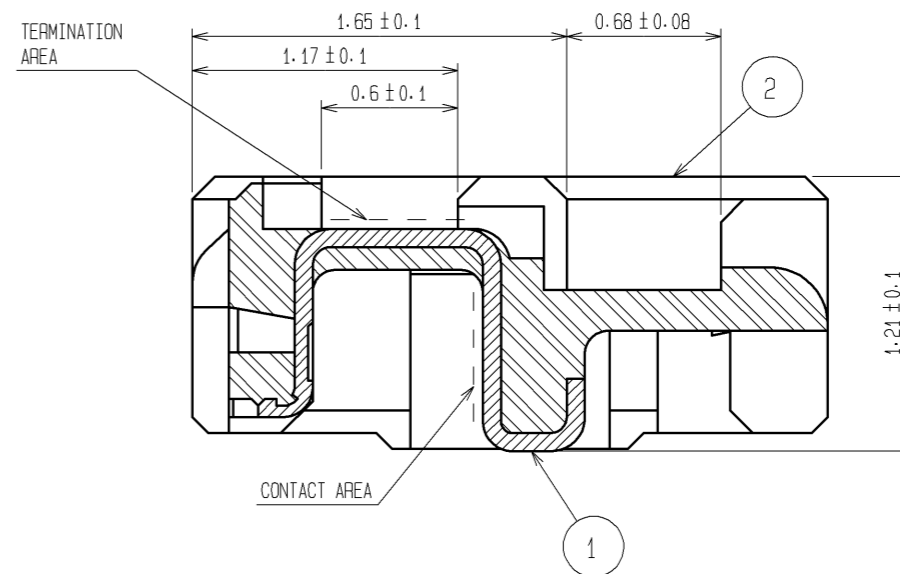

CABLE TERMINATION FIGURE(30:1)

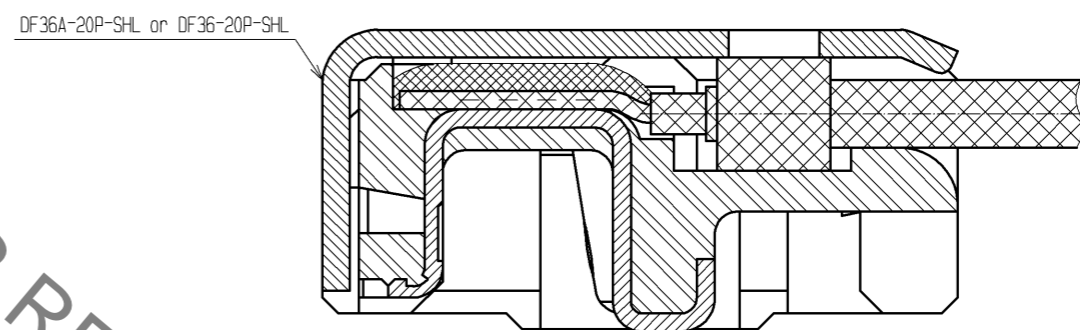

NOTES 1. APPLICABLE CABLE: THIN COAXIAL CABLE (AWG#42-AWG#46)
2. THIS CONNECTOR IS NOT HOT PLUGGABLE. MATE AND UNMATE WHILE THE POWER IS OFF.
3. THE ASSEMBLY IS COMPLETED BY COMBINING TWO PARTS "CONNECTOR UNIT AND METAL SHIELDING". REFER TO THE TABLE FOR EACH ITEM No., PART NAME, PART No. AND CODE No. APPLICABLE SHELL IS DIFFERENT DEPENDING ON THE PART No. OF MATED CONNECTOR. USE DF36A-20P-SHL FOR DF36A-20S-0.4V(**), USE DF36-20P-SHL FOR DF36-20S-0.4V(**).

ITEM No.	PART NAME	PART No.	CODE No.
1, 2	CONNECTOR UNIT	DF36-20P-0.4SD(55)	CL662-4040-2-55
-	METAL SHIELDING	DF36A-20P-SHL	CL662-4042-8-00
-	METAL SHIELDING	DF36-20P-SHL	CL662-4041-5-00

5	PS	BLACK
4	POLYESTER	CLEAR
3	PS	CLEAR
2	LCP	UL94V-0, BLACK

NO.	MATERIAL	FINISH	REMARKS	NO.	MATERIAL	FINISH	REMARKS
1	PHOSPHOR BRONZE	CONTACT AREA : GOLD PLATING 0.1µm min TERMINATION AREA : GOLD PLATING 0.1µm min UNDER PLATING : NICKEL PLATING 1µm min		5	PS	BLACK	

UNITS	SCALE	COUNT	DESCRIPTION OF REVISIONS	DESIGNED	CHECKED	DATE
mm	5 : 1	△				

APPROVED : MH. YAMANE	14. 07. 18	DRAWING NO.	EDC3-320378-02
CHECKED : MH. TSUCHIDA	14. 07. 17	PART NO.	DF36-20P-0.4SD(55)
DESIGNED : AH. MIYAZAKI	14. 07. 16	CODE NO.	CL662-4040-2-55
DRAWN : AH. MIYAZAKI	14. 07. 16		

Sep.1.2020 Copyright 2020 HIROSE ELECTRIC CO., LTD. All Rights Reserved.
 In case of consideration for using Automotive equipment / device which demand high reliability, kindly contact our sales window correspondents.

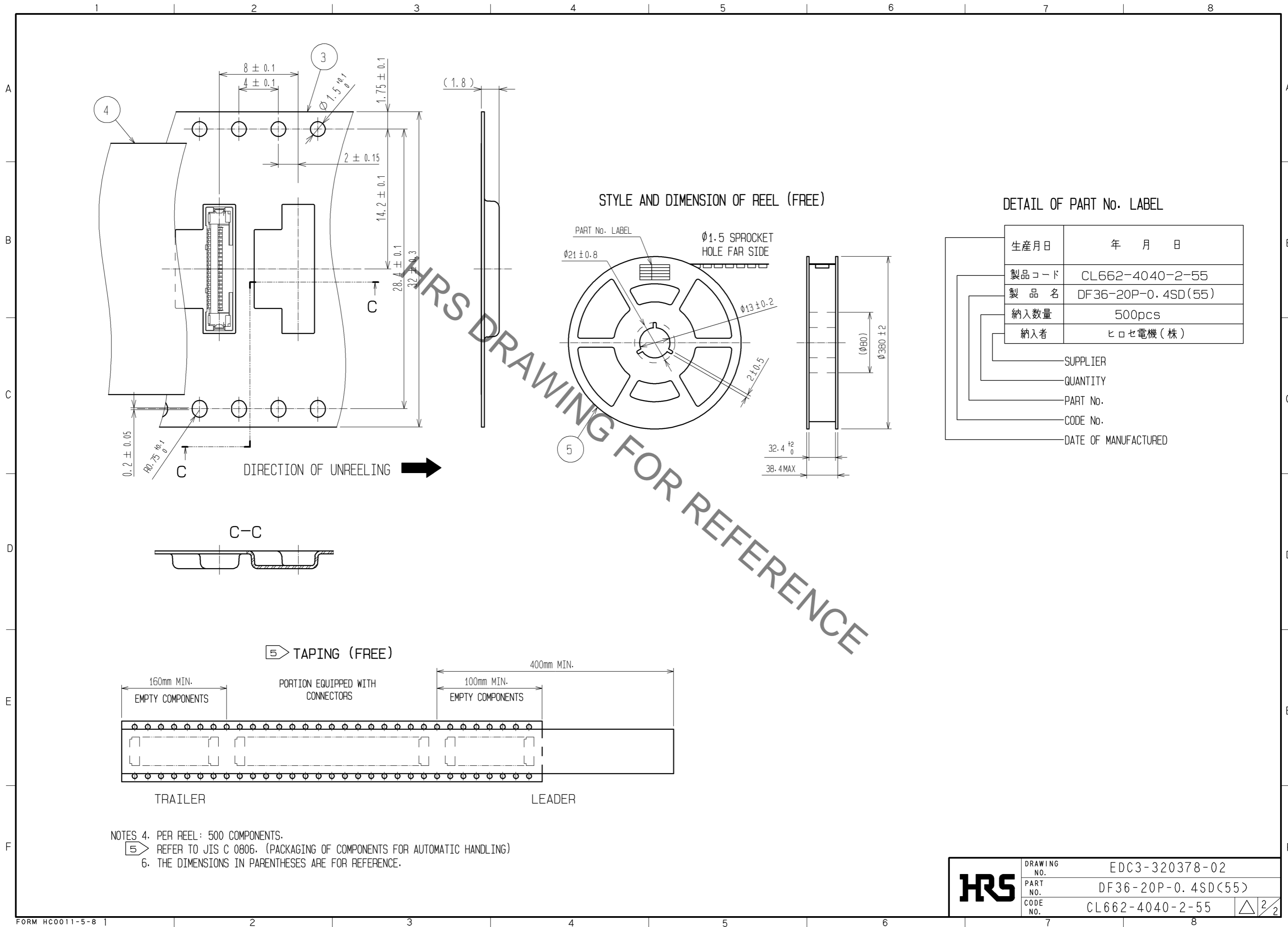

HRS DRAWING FOR REFERENCE

HRS	DRAWING NO.	EDC3-320378-02
	PART NO.	DF36-20P-0.4SD(55)
	CODE NO.	CL662-4040-2-55
		△ 2/2