

Power SMD LED PLCC-2 Plus

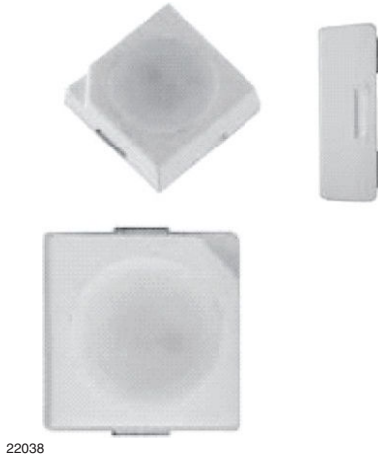

22038

DESCRIPTION

The VLMW51.. white LED in PLCC-2 plus package is an advanced product in terms of high luminous flux and low thermal resistance.

In combination with the small package outline (3.5 mm x 3.5 mm x 1.2 mm) the PLCC-2 plus is an ideal choice for backlighting, signage, exterior and interior automotive lighting as well as all general lighting applications.

PRODUCT GROUP AND PACKAGE DATA

- Product group: LED
- Package: SMD PLCC-2 plus
- Product series: power
- Angle of half intensity: $\pm 60^\circ$

FEATURES

- High efficient InGaN technology
- Long life, due to silicone resin casting
- Compact package outline 3.5 mm x 3.5 mm x 1.2 mm
- Angle of half intensity $\varphi = \pm 60^\circ$
- Luminous flux and color categorized per packing unit
- Luminous flux ratio per packing unit $\phi_{\max}/\phi_{\min} < 1.2$
- ESD-withstand voltage: up to 2 kV (HBM) according to JESD22-A114-B
- Preconditioning according to JEDEC® level 2
- Compatible with IR-reflow soldering profiles according to J-STD-020
- AEC-Q101 qualified
- Material categorization: for definitions of compliance please see www.vishay.com/doc?99912

AUTOMOTIVE GRADE

RoHS
 COMPLIANT
 HALOGEN
FREE
GREEN
 (5-2008)

APPLICATIONS

- Camera flash light
- Marker lights
- Interior and exterior automotive lighting
- Decorative lighting
- Architectural lighting
- All kinds of general lighting
- Backlighting (TFT LCD displays)

PARTS TABLE

PART	COLOR	LUMINOUS FLUX (mlm)			at I _F (mA)	COORDINATE (x, y)			at I _F (mA)	FORWARD VOLTAGE (V)			at I _F (mA)	TECHNOLOGY
		MIN.	TYP.	MAX.		MIN.	TYP.	MAX.		MIN.	TYP.	MAX.		
		VLMW51Q2R3-GS08	White	30 600		40 000	51 700	150		-	0.33, 0.33	-		

ABSOLUTE MAXIMUM RATINGS (T_{amb} = 25 °C, unless otherwise specified)

VLMW51Q2R3

PARAMETER	TEST CONDITION	SYMBOL	VALUE	UNIT
DC Forward current		I _F	180	mA
Surge forward current	t _p ≤ 10 μs	I _{FSM}	350	mA
Power dissipation		PV	738	mW
Junction temperature		T _{jmax.}	125	°C
Operating temperature range		T _{amb}	-40 to +100	°C
Storage temperature range		T _{stg}	-40 to +100	°C
Thermal resistance junction-to-solder point		R _{thJS}	45	K/W
Thermal resistance junction-to-ambient	Mounted on PC board total Cu area > 900 mm ²	R _{thJA}	125	K/W

Note

- Not designed for reverse bias

**OPTICAL AND ELECTRICAL CHARACTERISTICS** ($T_{amb} = 25\text{ }^{\circ}\text{C}$, unless otherwise specified)
VLMW51P2Q3, WHITE

PARAMETER	TEST CONDITION	PART	SYMBOL	MIN.	TYP.	MAX.	UNIT
Luminous flux	$I_F = 150\text{ mA}$	VLMW51Q2R3	ϕ_V	30.6	40	51.7	lm
Luminous intensity	$I_F = 150\text{ mA}$	VLMW51Q2R3	I_V	-	13	-	cd
Chromaticity coordinate x, y according to CIE 1931	$I_F = 150\text{ mA}$		x	-	0.33	-	
			y	-	0.33	-	
Angle of half intensity	$I_F = 150\text{ mA}$		ϕ	-	± 60	-	deg
Forward voltage	$I_F = 150\text{ mA}$		V_F	3	3.4	4.1	V
Temperature coefficient of V_F	$I_F = 150\text{ mA}$		TC_{VF}	-	-3.7	-	mV/K
Temperature coefficient of I_V	$I_F = 150\text{ mA}$		TC_{IV}	-	-0.25	-	%/K
Temperature coefficient of x	$I_F = 150\text{ mA}$		TC_x	-	-0.00022	-	1/K
Temperature coefficient of y	$I_F = 150\text{ mA}$		TC_y	-	-0.00016	-	1/K

Note

- Not designed for reverse bias

LUMINOUS FLUX CLASSIFICATION

GROUP	LUMINOUS FLUX (lm)		
	STANDARD	MIN.	MAX.
Q2		30.6	34.8
Q3		34.8	39.8
R2		39.8	45.2
R3		45.2	51.7

Note

- Luminous flux is tested at a current pulse duration of 25 ms and an accuracy of $\pm 11\%$.
The above type numbers represent the order groups which include only a few brightness groups. Only one group will be shipped on each reel (there will be no mixing of two groups on each reel).
In order to ensure availability, single brightness groups will not be orderable.
In a similar manner for colors where wavelength groups are measured and binned, single wavelength groups will be shipped on any one reel.
In order to ensure availability, single wavelength groups will not be orderable

CHROMATICITY COORDINATED GROUPS FOR WHITE PLCC-2 PLUS

	X	Y		X	Y
YU	0.274	0.301	WL	0.317	0.325
	0.283	0.284		0.319	0.310
	0.307	0.316		0.329	0.319
	0.303	0.333		0.329	0.336
YL	0.283	0.284	VU	0.329	0.354
	0.290	0.270		0.329	0.336
	0.310	0.299		0.345	0.350
	0.307	0.316		0.347	0.368
XU	0.303	0.333	VL	0.329	0.336
	0.307	0.316		0.329	0.319
	0.317	0.325		0.343	0.331
	0.315	0.343		0.345	0.350
XL	0.307	0.316	UU	0.347	0.368
	0.310	0.299		0.345	0.350
	0.319	0.310		0.361	0.365
	0.317	0.325		0.364	0.383
WU	0.315	0.343	UL	0.345	0.350
	0.317	0.325		0.343	0.331
	0.329	0.336		0.357	0.343
	0.329	0.354		0.361	0.365

Note

- Chromaticity coordinate groups are tested at a current pulse duration of 25 ms and a tolerance of ± 0.01

TYPICAL CHARACTERISTICS ($T_{amb} = 25\text{ }^{\circ}\text{C}$, unless otherwise specified)

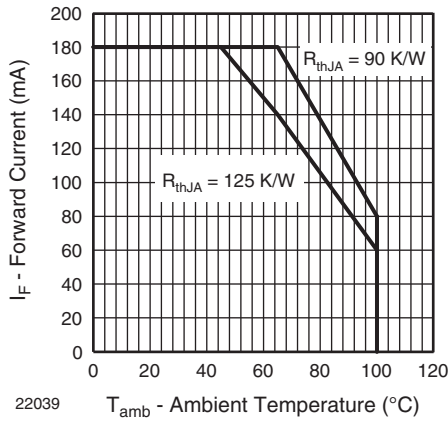

Fig. 1 - Forward Current vs. Ambient Temperature

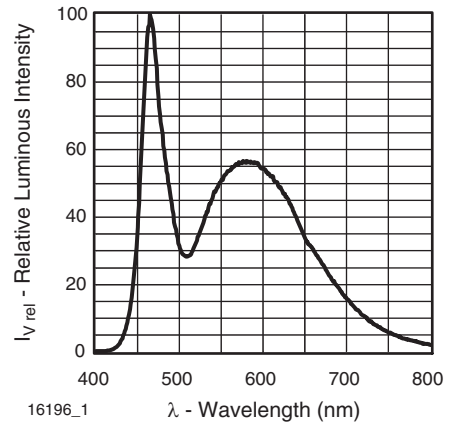

Fig. 4 - Relative Intensity vs. Wavelength

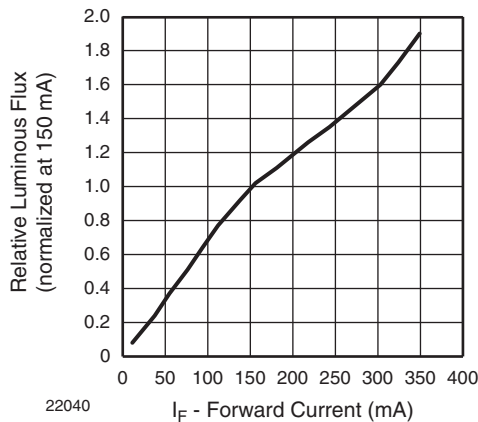

Fig. 2 - Relative Luminous Intensity vs. Forward Current

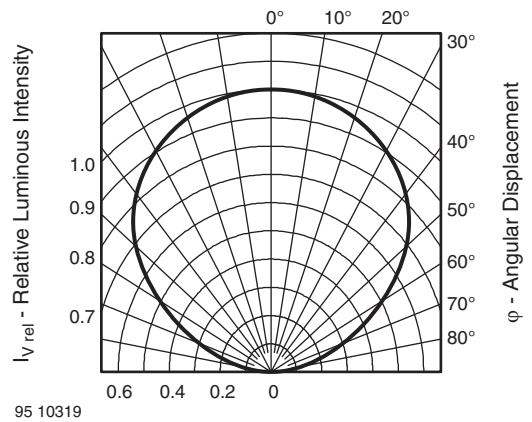

Fig. 5 - Relative Luminous Intensity vs. Angular Displacement

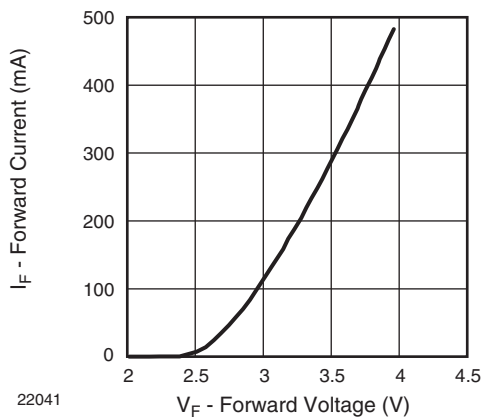

Fig. 3 - Forward Current vs. Forward Voltage

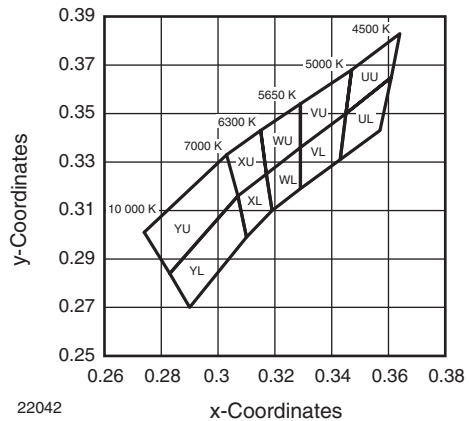
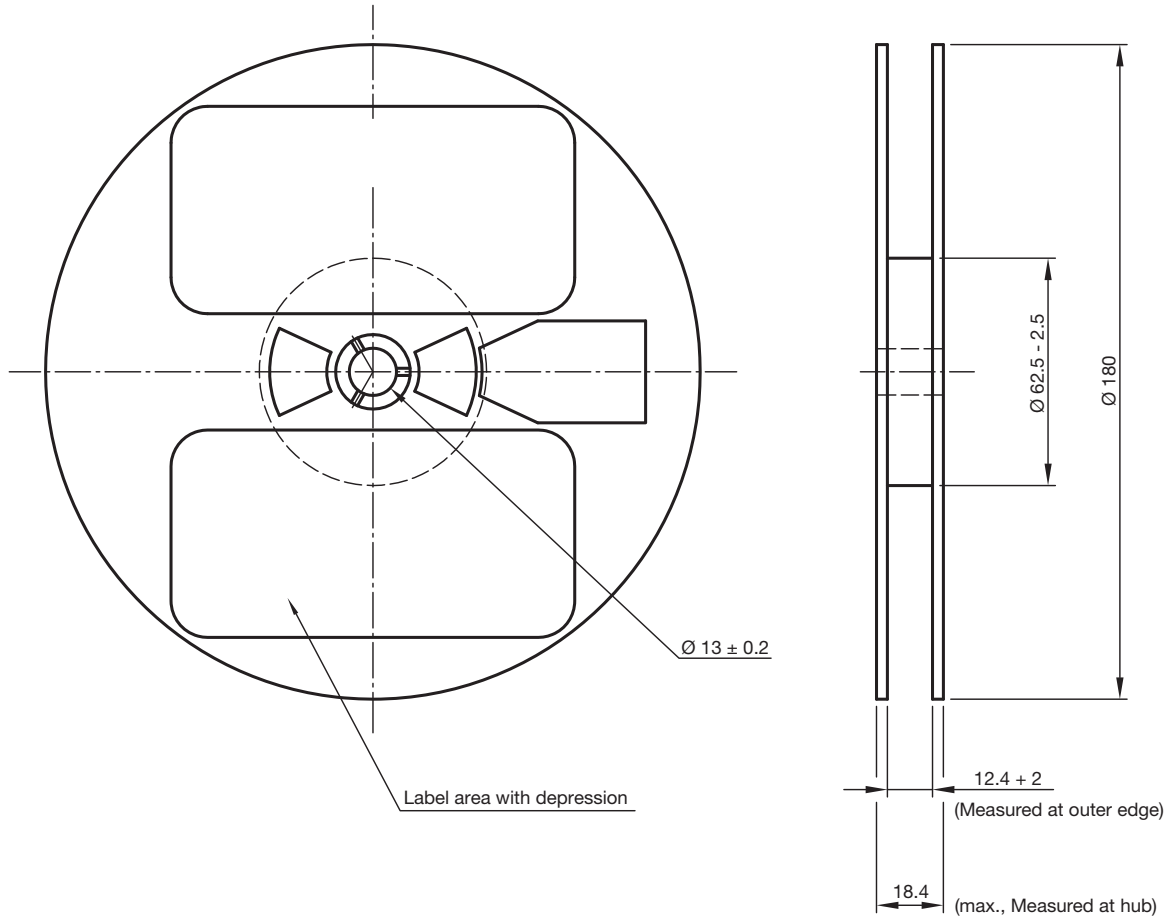

Fig. 6 - White Grouping SMD



REEL DIMENSIONS in millimeters



technical drawings according to DIN specifications

Not indicated tolerances ± 0.5

Material: black static dissipative

GS08 = 1000 pcs

Drawing-No.: 9.800-5104.01-4

Issue: 2; 19.03.10

22067



TAPING AND ORIENTATION DIMENSIONS in millimeters

Reels come in quantity of 1000 units.

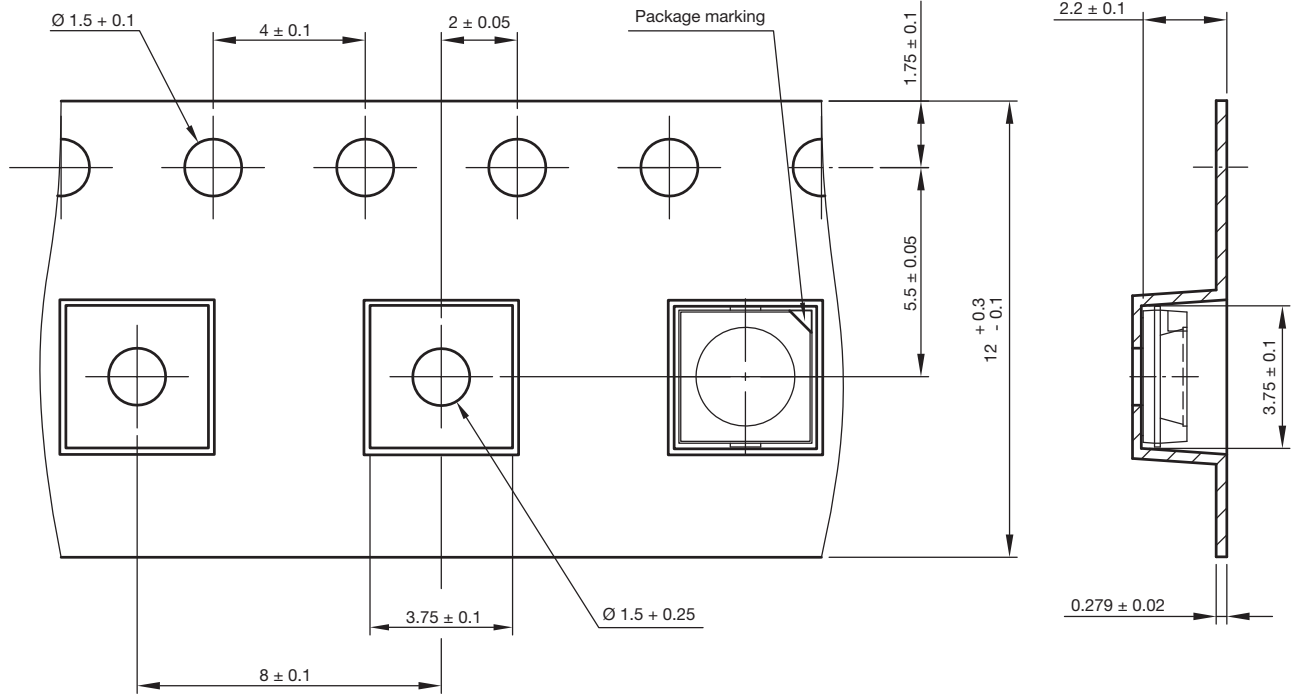

200 mm min. for $\varnothing 180$ reel

480 mm min. for $\varnothing 180$ reel

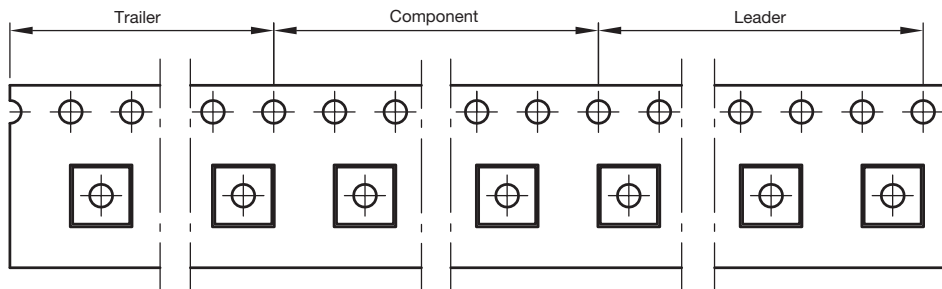

User feed direction

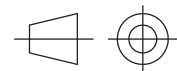

technical drawings according to DIN specifications

Drawing-No.: 9.700-5348.01-4

Issue: 1; 01.03.10

22066



RECOMMENDED PAD DESIGN DIMENSIONS in millimeters

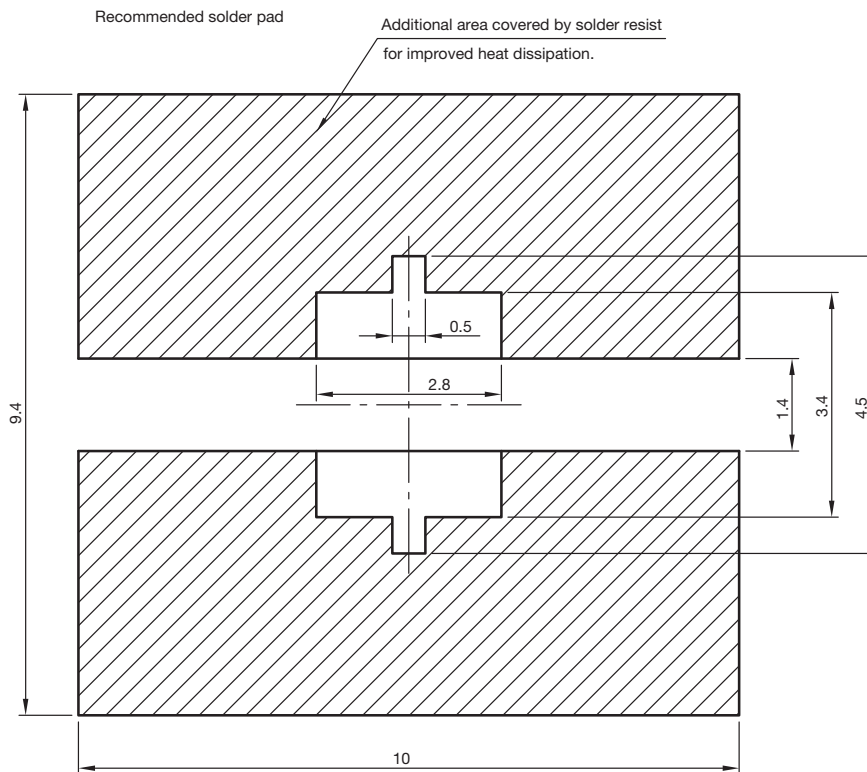
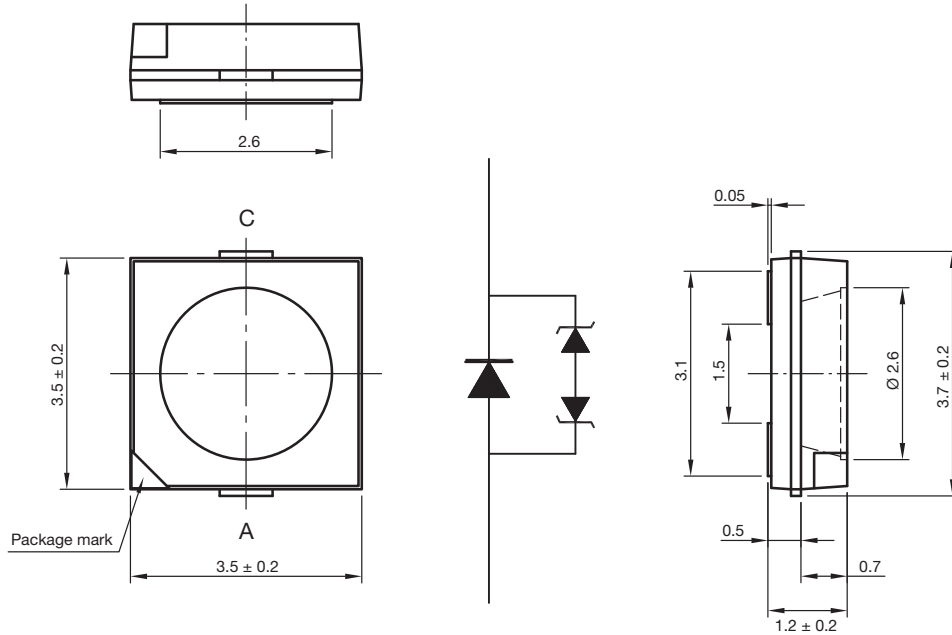

technical drawings according to DIN specifications

Drawing-No.: 6.541-5082.01-4
 Issue: 2; 23.07.10
 22065

SOLDERING PROFILE

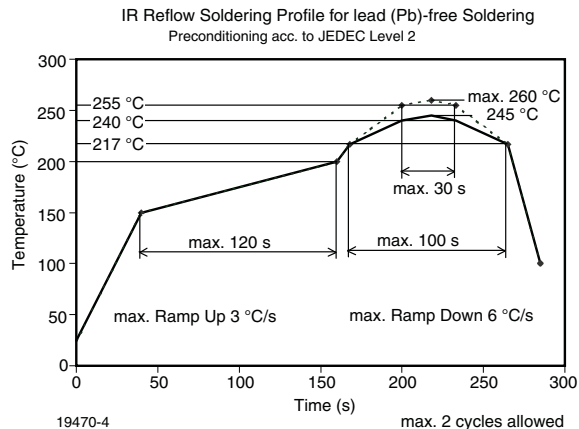
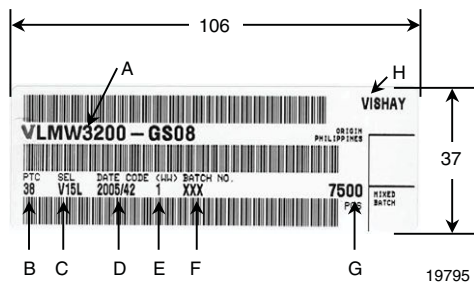

Fig. 7 - Vishay Lead (Pb)-free Reflow Soldering Profile (according to J-STD-020)

BAR CODE PRODUCT LABEL (example)



- A) Type of component
- B) Manufacturing plant
- C) SEL - selection code (bin):
e.g.: V1 = code for luminous intensity group
5L = code for chrom. coordinate group
- D) Date code year/week
- E) Day code (e. g. 1: Monday)
- F) Batch no.
- G) Total quantity
- H) Company code

DRY PACKING

The reel is packed in an anti-humidity bag to protect the devices from absorbing moisture during transportation and storage.

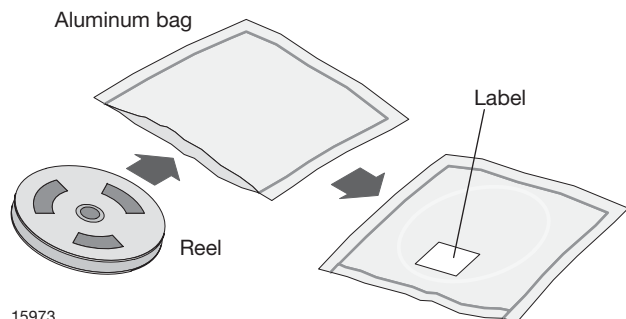

15973

FINAL PACKING

The sealed reel is packed into a cardboard box. A secondary cardboard box is used for shipping purposes.

RECOMMENDED METHOD OF STORAGE

Dry box storage is recommended as soon as the aluminum bag has been opened to prevent moisture absorption. The following conditions should be observed, if dry boxes are not available:

- Storage temperature 10 °C to 30 °C
- Storage humidity ≤ 60 % RH max.

After more than 1 year under these conditions moisture content will be too high for reflow soldering.

In case of moisture absorption, the devices will recover to the former condition by drying under the following condition:

- 192 h at 40 °C + 5 °C/- 0 °C and < 5 % RH (dry air/nitrogen) or
- 96 h at 60 °C + 5 °C and < 5 % RH for all device containers or
- 24 h at 100 °C + 5 °C not suitable for reel or tubes

An EIA JEDEC standard JESD22-A112 level 2 label is included on all dry bags.

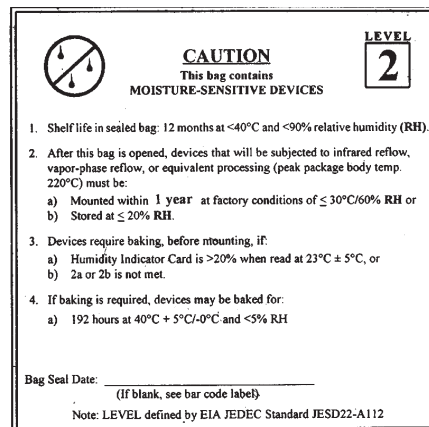

17028

Example of JESD22-A112 level 2 label

ESD PRECAUTION

Proper storage and handling procedures should be followed to prevent ESD damage to the devices especially when they are removed from the antistatic shielding bag. Electro-static sensitive devices warning labels are on the packaging.



Disclaimer

ALL PRODUCT, PRODUCT SPECIFICATIONS AND DATA ARE SUBJECT TO CHANGE WITHOUT NOTICE TO IMPROVE RELIABILITY, FUNCTION OR DESIGN OR OTHERWISE.

Vishay Intertechnology, Inc., its affiliates, agents, and employees, and all persons acting on its or their behalf (collectively, "Vishay"), disclaim any and all liability for any errors, inaccuracies or incompleteness contained in any datasheet or in any other disclosure relating to any product.

Vishay makes no warranty, representation or guarantee regarding the suitability of the products for any particular purpose or the continuing production of any product. To the maximum extent permitted by applicable law, Vishay disclaims (i) any and all liability arising out of the application or use of any product, (ii) any and all liability, including without limitation special, consequential or incidental damages, and (iii) any and all implied warranties, including warranties of fitness for particular purpose, non-infringement and merchantability.

Statements regarding the suitability of products for certain types of applications are based on Vishay's knowledge of typical requirements that are often placed on Vishay products in generic applications. Such statements are not binding statements about the suitability of products for a particular application. It is the customer's responsibility to validate that a particular product with the properties described in the product specification is suitable for use in a particular application. Parameters provided in datasheets and / or specifications may vary in different applications and performance may vary over time. All operating parameters, including typical parameters, must be validated for each customer application by the customer's technical experts. Product specifications do not expand or otherwise modify Vishay's terms and conditions of purchase, including but not limited to the warranty expressed therein.

Except as expressly indicated in writing, Vishay products are not designed for use in medical, life-saving, or life-sustaining applications or for any other application in which the failure of the Vishay product could result in personal injury or death. Customers using or selling Vishay products not expressly indicated for use in such applications do so at their own risk. Please contact authorized Vishay personnel to obtain written terms and conditions regarding products designed for such applications.

No license, express or implied, by estoppel or otherwise, to any intellectual property rights is granted by this document or by any conduct of Vishay. Product names and markings noted herein may be trademarks of their respective owners.