

# Features

# Switching Regulator

- Efficiency up to 94%, no need for heatsinks
- Pin-out compatible with LM78XX linears
- Low profile (L/W/H=11.5 x 7.5 x 10.2mm)
- Wide input range
- Short circuit protection, thermal shutdown
- Non-standard outputs available as specials
- Low ripple and noise



## R-78-1.0

1.0 Amp  
SIP3  
Single Output



### Description

The R-78xx-1.0 series switching regulators are ideally suited to replace 1 Amp 78xx linear regulators and are pin compatible. Efficiencies of up to 94% means that very little energy is wasted as heat so there is no need for any heat sinks with their additional space and mounting costs.

### Selection Guide

Part Number	Input Voltage Range [VDC]	Output Voltage [VDC]	Output Current [A]	Efficiency	
				@ min Vin [%]	@ max. Vin [%]
R-781.8-1.0	4.75 - 18	1.8	1.0	82	76
R-782.5-1.0	4.75 - 18	2.5	1.0	87	81
R-783.3-1.0	4.75 - 18	3.3	1.0	90	84
R-785.0-1.0	6.5 - 18	5.0	1.0	94	89

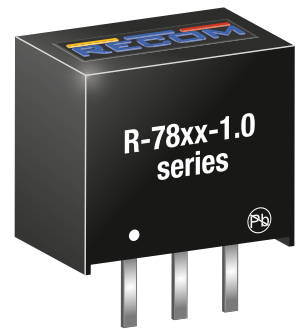

### Model Numbering

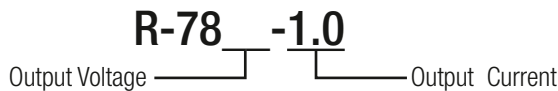

IEC/EN60950-1 certified  
EN55032 compliant

### Specifications (measured @ Ta= 25°C, 10% minimum load, unless otherwise stated)

BASIC CHARACTERISTICS				
Parameter	Condition	Min.	Typ.	Max.
Input Voltage Range	nom. Vin=12VDC	4.75VDC		18VDC
Quiescent Current	Vin = min. to max. at 0% load		5mA	7mA
Internal Power Dissipation				0.4W
Minimum Load <sup>(1)</sup>		0%		
Internal Operating Frequency		280kHz	350kHz	430kHz
Output Ripple and Noise	measured at 20MHz BW		20mVp-p	30mVp-p
Absolute Maximum Capacitive Load	1 second start up, no external components			220µF
	<1 second start up + diode protection circuit			6800µF
<b>Notes:</b> Note1: Operation under no load will not harm the converter, but specifications may not be met A minimum load of 10mA is recommended				
continued on next page				

Specifications (measured @ Ta= 25°C, 10% minimum load, unless otherwise stated)

Efficiency vs. Vin (full load)

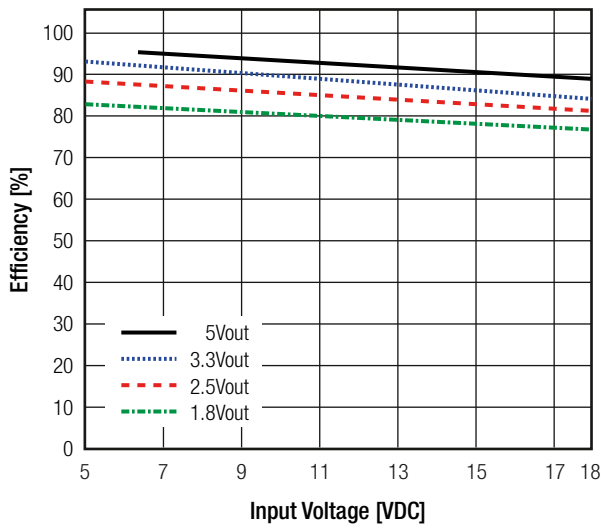

Ripple vs. Vin (full load)

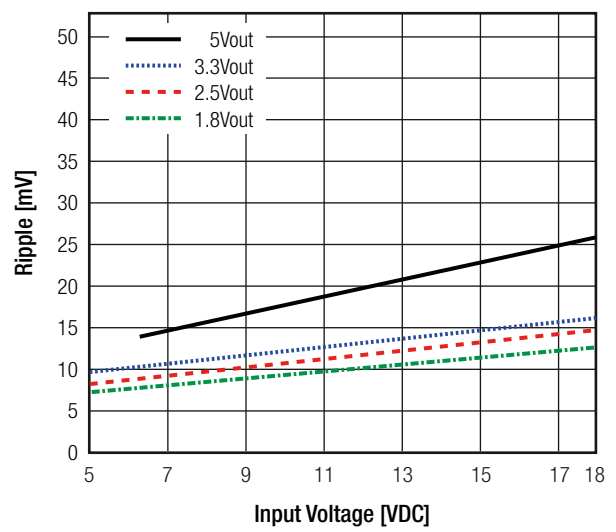

Efficiency vs. Load (max. Vin)

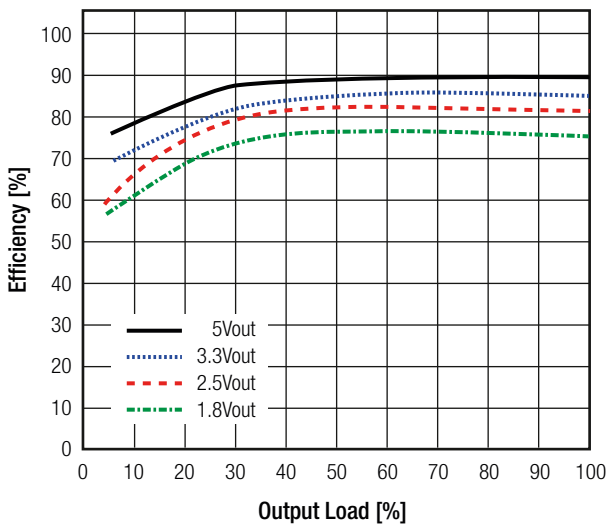

Ripple vs. Load (max. Vin)

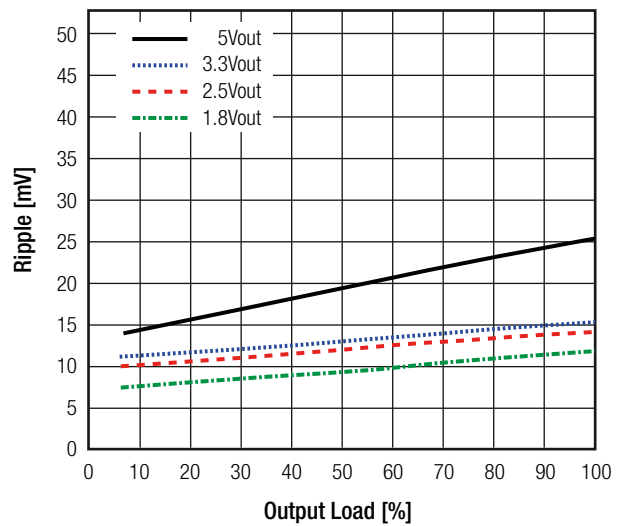

Efficiency vs. Load (min. Vin)

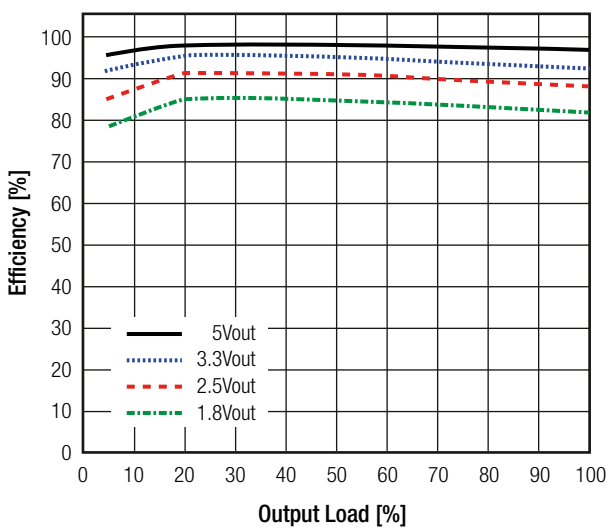

Ripple vs. Load (min. Vin)

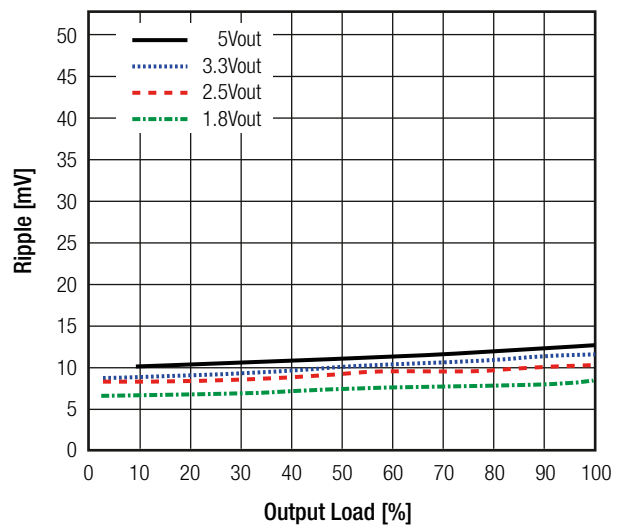

**Specifications** (measured @ Ta= 25°C, 10% minimum load, unless otherwise stated)

REGULATIONS		
Parameter	Condition	Value
Output Accuracy	100% load	±2.0% typ / ±3.0% max.
Line Regulation	low line to high line	±0.2% typ. / ±0.4% max.
Load Regulation	10% to 100% load	±0.4% typ. / ±0.6% max.
Transient Response	100% <-> 50% load	±85mV typ. / ±100mV max.

PROTECTIONS		
Parameter	Condition	Value
Short Circuit Protection (SCP)		continuous, automatic recovery
Short Circuit Input Current	nom. Vin= 12VDC	100mA max.

**Optional Diode Protection Circuit**

Add a blocking diode to Vout if current can flow backwards into the output, as this can damage the converter when it is powered down.

The diode can either be fitted across the device if the source is low impedance or fitted in series with the output (recommended).

**Optional Protection 1:**

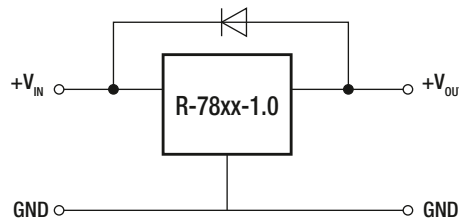

**Optional Protection 2:**

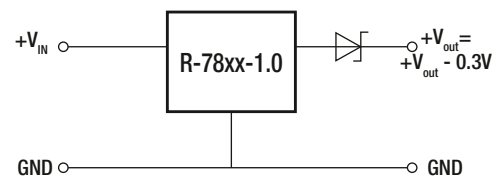

ENVIRONMENTAL			
Parameter	Condition		Value
Operating Temperature Range	with derating (see graph)		-40°C to +85°C
Maximum Case Temperature			+100°C
Temperature Coefficient			±0.015%/°C
Thermal Impedance	0.1 m/s, vertical		70°C/W
Operating Altitude			2000m
Operating Humidity	non-condensing		95% RH max.
Pollution Degree			PD2
MTBF	according to MIL-HDBK-217F, G.B.	+25°C +71°C	13338 x 10 <sup>3</sup> hours 3880 x 10 <sup>3</sup> hours

**Derating Graph**

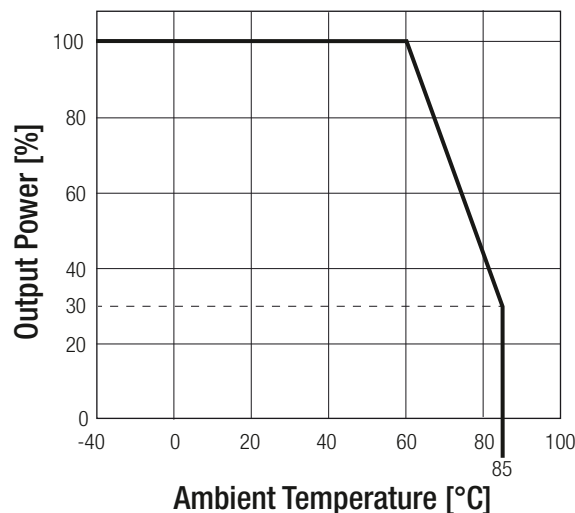

**Specifications** (measured @ Ta= 25°C, 10% minimum load, unless otherwise stated)

### SAFETY AND CERTIFICATIONS

Certificate Type (Safety)	Report / File Number	Standard
Information Technology Equipment, General Requirements for Safety	1603123	IEC60950-1:2005, 2nd Edition + AM 2:2013 EN60950-1:2006 + AM 2:2013
EAC	RU-AT.49.09571	TP TC 004/2011
RoHs 2+		RoHS 2011/65/EU + AM2015/863

EMC Compliance	Condition	Standard / Criterion
Electromagnetic compatibility of multimedia equipment - Emission requirements	with external components	EN55032, Class A EN55032, Class B
ESD Electrostatic discharge immunity test	Contact $\pm 6kV$	EN61000-4-2, Criteria A
Radiated, radio-frequency, electromagnetic field immunity test	3V/m	EN61000-4-3, Criteria A
Fast Transient and Burst Immunity	$\pm 1.0kV$	EN61000-4-4, Criteria A
Immunity to conducted disturbances, induced by radio-frequency fields	3V	EN61000-4-6, Criteria A
Power Magnetic Field Immunity	50Hz, 3A/m	EN61000-4-8, Criteria A

### EMC Filter Suggestion according to EN55032 Class A and B

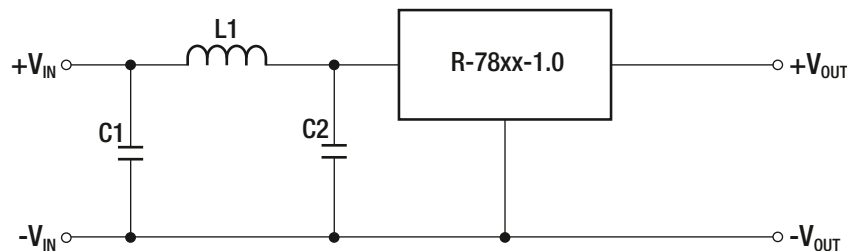

Level	C1	C2	L1
Class A	10 $\mu$ F 100V MLCC	-	3.9 $\mu$ H choke
Class B	10 $\mu$ F 100V MLCC	2.2 $\mu$ F 100V MLCC	5.6 $\mu$ H choke

### DIMENSION AND PHYSICAL CHARACTERISTICS

Parameter	Type	Value
Material	case potting PCB	non-conductive black plastic, (UL94 V-0) silicone, (UL94 V-0) FR4, (UL94 V-0)
Package Dimension (LxWxH)		11.5 x 7.55 x 10.2mm
Package Weight		1.9g typ.

continued on next page

Specifications (measured @ Ta= 25°C, 10% minimum load, unless otherwise stated)

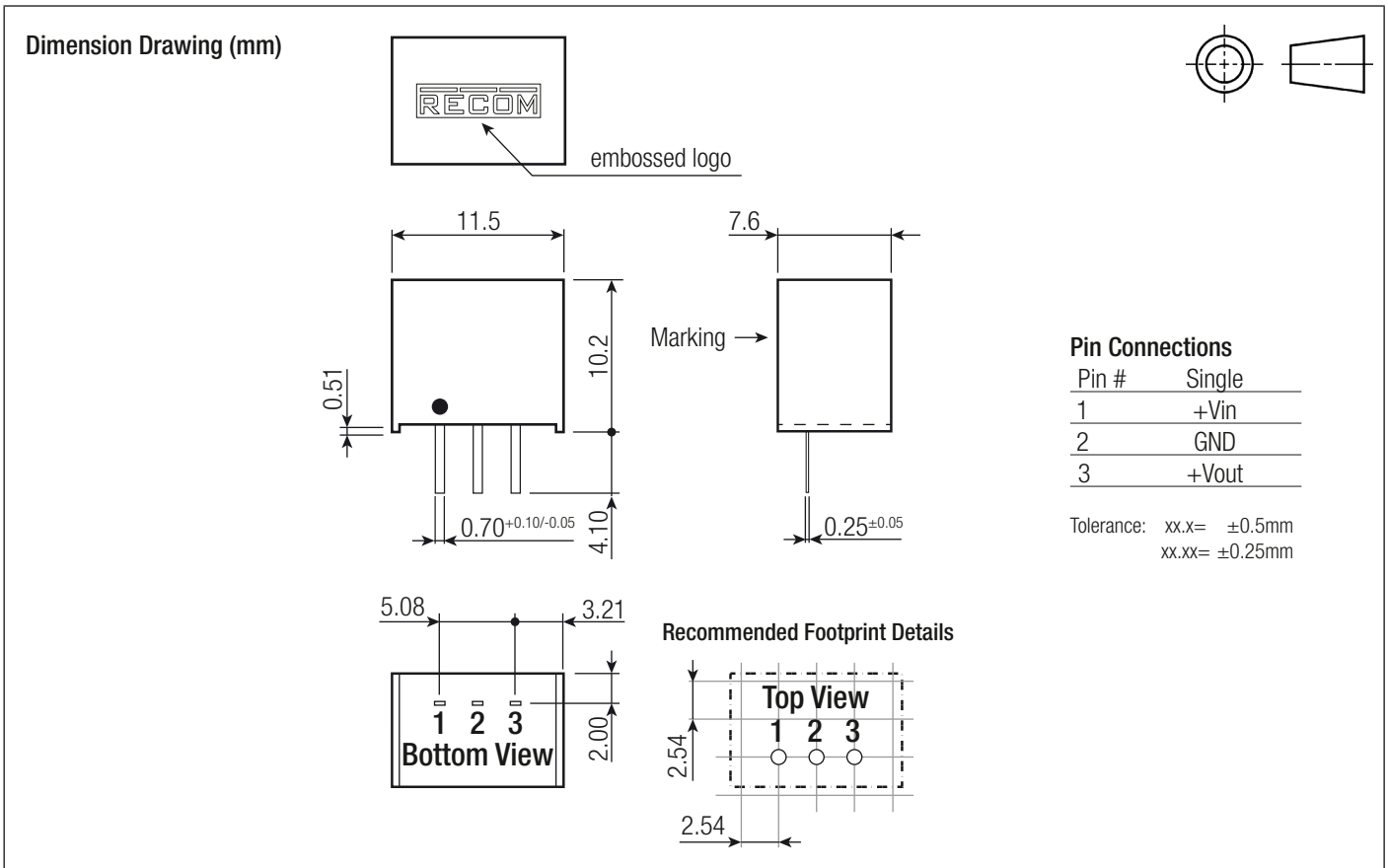

## INSTALLATION AND APPLICATION

### High Efficiency, Isolated, Dual Unregulated Output

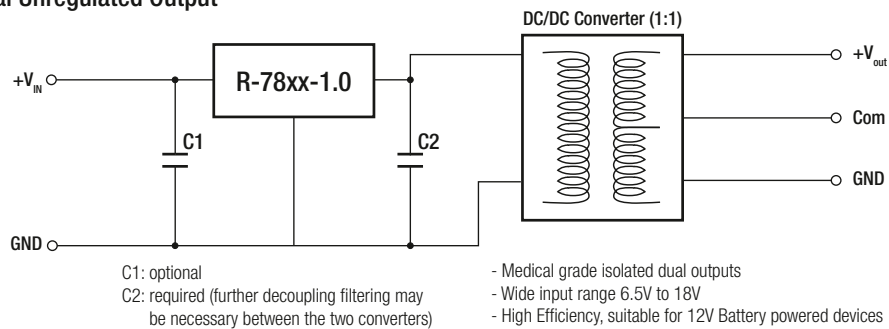

### Isolated (up to 6kVDC), Wide Input Range Regulated Output

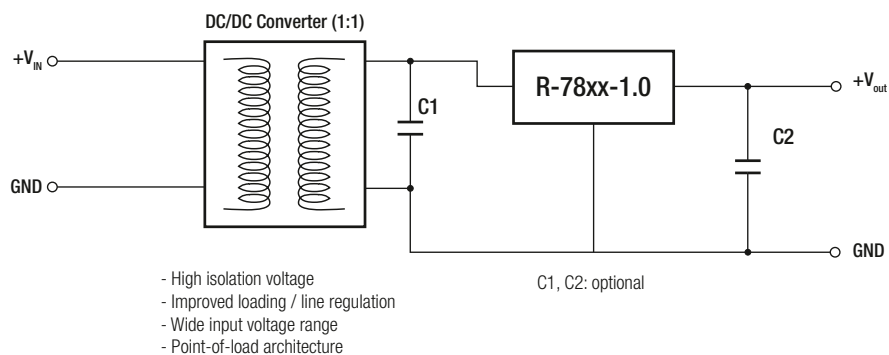

**Specifications** (measured @ Ta= 25°C, 10% minimum load, unless otherwise stated)

PACKAGING INFORMATION		
Parameter	Type	Value
Packaging Dimension (LxWxH)	tube	520.0 x 9.3 x 16.5mm
Packaging Quantity	tube	42pcs
Storage Temperature Range		-55°C to +125°C
Storage Humidity		95% RH max.

The product information and specifications may be subject to changes even without prior written notice. The product has been designed for various applications; its suitability lies in the responsibility of each customer. The products are not authorized for use in safety-critical applications without RECOM's explicit written consent. A safety-critical application is an application where a failure may reasonably be expected to endanger or cause loss of life, inflict bodily harm or damage property. The applicant shall indemnify and hold harmless RECOM, its affiliated companies and its representatives against any damage claims in connection with the unauthorized use of RECOM products in such safety-critical applications.

# Mouser Electronics

Authorized Distributor

Click to View Pricing, Inventory, Delivery & Lifecycle Information:

[RECOM:](#)

[R-785.0-1.0](#) [R-781.8-1.0](#) [R-782.5-1.0](#) [R-783.3-1.0](#)