

## Memory Module Digital Temperature Sensor

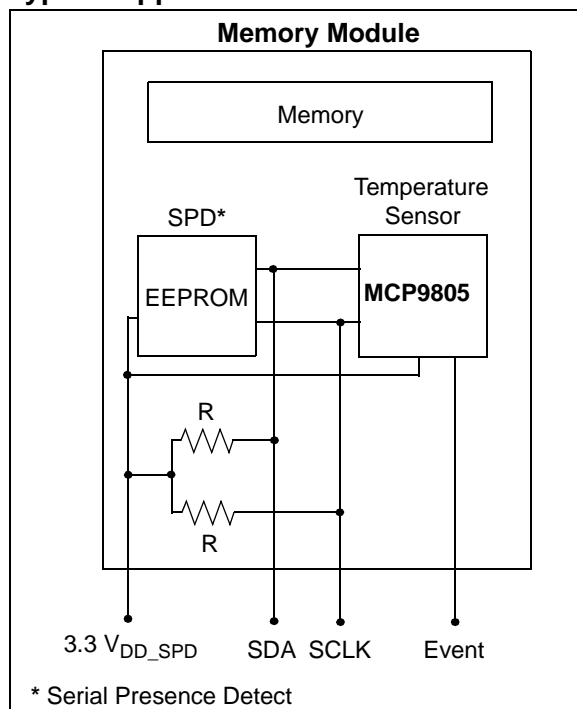
### Features

- Meets JEDEC Standard JC42.4 for Mobile Platform Memory Module Thermal Sensor
- Temperature-to-Digital Converter
- Accuracy with 0.25 °C/LSb Resolution:
  - $\pm 1^{\circ}\text{C}$  (max.) from  $+75^{\circ}\text{C}$  to  $+95^{\circ}\text{C}$
  - $\pm 2^{\circ}\text{C}$  (max.) from  $+40^{\circ}\text{C}$  to  $+125^{\circ}\text{C}$
  - $\pm 3^{\circ}\text{C}$  (max.) from  $-20^{\circ}\text{C}$  to  $+125^{\circ}\text{C}$
- Programmable Temperature Monitor Boundary
- Critical Temperature Output
- Operating Voltage Range: 3.0V to 3.6V
- 2-wire Interface: SMBus/Standard mode I<sup>2</sup>C™ Compatible
- Operating Current: 200  $\mu\text{A}$  (typ.)
- Shutdown Current: 0.1  $\mu\text{A}$  (typ.)
- Available Packages: 2x3 DFN-8, TSSOP-8

### Typical Applications

- Dual In-line Memory Module (DIMM)
- Personal Computers (PCs) and Servers
- Hard Disk Drives and Other PC Peripherals
- General Purpose Temperature Sensor

### Typical Application



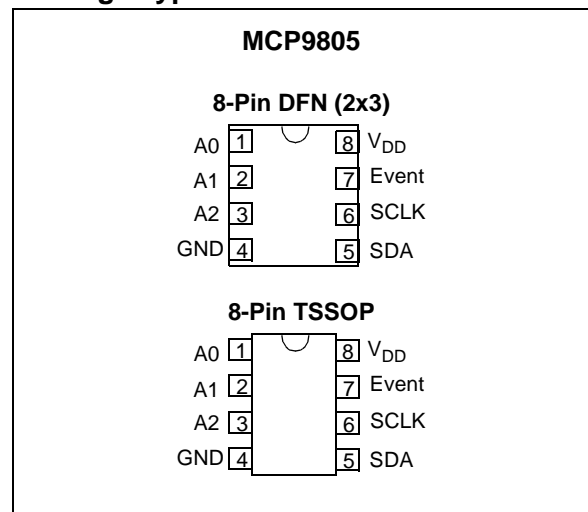
### Description

Microchip Technology Inc.'s MCP9805 digital temperature sensor converts temperatures between  $-40^{\circ}\text{C}$  and  $+125^{\circ}\text{C}$  to a digital word. This sensor is designed to meet the JEDEC standard JC42.4 for Mobile Platform Memory Module Thermal Sensor. This device provides an accuracy of  $\pm 1^{\circ}\text{C}$  (max.) from a temperature range of  $+75^{\circ}\text{C}$  to  $+95^{\circ}\text{C}$  (active range) and  $\pm 2^{\circ}\text{C}$  (max.) from  $+40^{\circ}\text{C}$  to  $+125^{\circ}\text{C}$  (monitor range) as defined in the JEDEC standard.

The MCP9805 comes with user-programmable registers that provide flexibility for DIMM temperature-sensing applications. The registers allow user-selectable settings such as Shutdown or Low-Power modes and the specification of temperature event and critical output boundaries. When the temperature changes beyond the specified boundary limits, the MCP9805 outputs an Event signal. The user has the option of setting the Event output signal polarity as either an active-low or active-high comparator output for thermostat operation, or as a temperature event interrupt output for microprocessor-based systems. The Event output can also be configured as a critical temperature output.

This sensor has a 2-wire industry-standard SMBus and Standard mode I<sup>2</sup>C compatible (100 kHz bus clock) serial interface protocol, allowing up to eight sensors to be controlled in a single serial bus. These features make the MCP9805 ideal for sophisticated multi-zone temperature-monitoring applications.

### Package Types



# MCP9805

## 1.0 ELECTRICAL CHARACTERISTICS

### Absolute Maximum Ratings †

V <sub>DD</sub> .....	6.0V
Voltage at all Input/Output pins ....	GND – 0.3V to 5.5V
Storage temperature .....	-65°C to +150°C
Ambient temp. with power applied .....	-40°C to +125°C
Junction Temperature (T <sub>J</sub> ).....	+150°C
ESD protection on all pins (HBM:MM).....	(4 kV:200V)
Latch-Up Current at each pin .....	±200 mA

†**Notice:** Stresses above those listed under “Maximum ratings” may cause permanent damage to the device. This is a stress rating only and functional operation of the device at those or any other conditions above those indicated in the operational listings of this specification is not implied. Exposure to maximum rating conditions for extended periods may affect device reliability.

### DC CHARACTERISTICS

**Electrical Specifications:** Unless otherwise indicated, V<sub>DD</sub> = 3.0V to 3.6V, GND = Ground and T<sub>A</sub> = -20°C to +125°C.

Parameters	Sym	Min	Typ	Max	Unit	Conditions
<b>Power Supply</b>						
Operating Voltage Range	V <sub>DD</sub>	3.0	—	3.6	V	
Operating Current	I <sub>DD</sub>	—	200	500	µA	Continuous Operation
Shutdown Current	I <sub>SHDN</sub>	—	0.1	2	µA	Shutdown Mode
Power-On Reset Threshold (POR)	V <sub>POR</sub>	—	2.2	—	V	V <sub>DD</sub> Falling Edge
Power Supply Rejection	PSR <sub>DC</sub>	—	±0.3	—	°C	
	PSR <sub>AC</sub>	—	±0.5	—	°C	V <sub>DD</sub> = 3.3V + 150 mVpp (0 to 1 MHz), T <sub>A</sub> = +25°C
<b>Temperature Sensor Accuracy</b>						
Accuracy with 0.25 °C/LSb Resolution:						
+75°C to +95°C	T <sub>ACY</sub>	-1.0	±0.5	+1.0	°C	Active Temp. Range
+40°C to +125°C	T <sub>ACY</sub>	-2.0	±1.0	+2.0	°C	Monitor Temp. Range
-20°C to +125°C	T <sub>ACY</sub>	-3.0	±2.0	+3.0	°C	
T <sub>A</sub> = -40°C	T <sub>ACY</sub>	—	±2	—	°C	
<b>Internal ΔΣ ADC</b>						
Conversion Time (10-bits + Sign):						
0.25 °C/LSb	t <sub>CONV</sub>	—	65	125	ms	17 samples/sec. (typ.)
<b>Event Output (Open-Drain)</b>						
High-Level Current (leakage)	I <sub>OH</sub>	—	—	1	µA	V <sub>OH</sub> = 3.6V
Low-Level Voltage	V <sub>OL</sub>	—	—	0.4	V	I <sub>OL</sub> = 3 mA
<b>Thermal Response</b>						
Response Time ( <b>Note</b> ):						
DFN	t <sub>RES</sub>	—	0.7	—	s	Time to 63% of +22°C (Air) to +125°C (Oil Bath)
TSSOP	t <sub>RES</sub>	—	1.5	—	s	

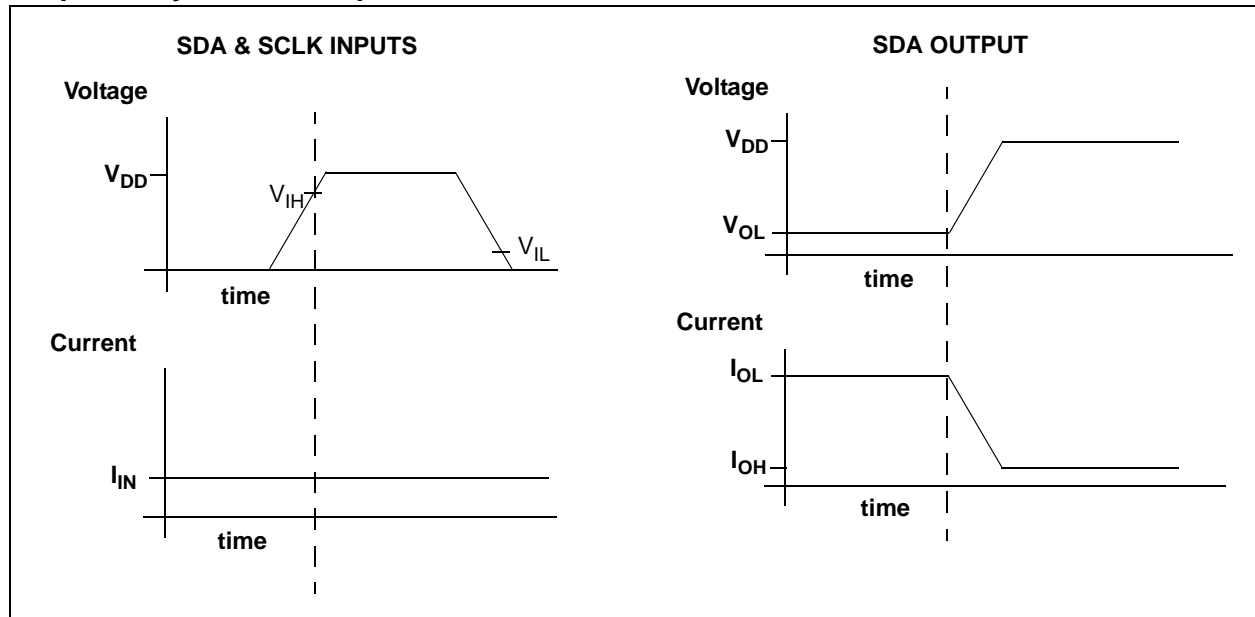
**Note:** Thermal response with 1x1 inch dual-sided copper clad.

## DIGITAL INPUT/OUTPUT PIN CHARACTERISTICS

**Electrical Specifications:** Unless otherwise indicated,  $V_{DD} = 3.0V$  to  $3.6V$ , GND = Ground and  $T_A = -20^{\circ}C$  to  $+125^{\circ}C$ .

Parameters	Sym	Min	Typ	Max	Units	Conditions
<b>Serial Input/Output (SCLK, SDA, A0, A1, A2)</b>						
<b>Input</b>						
High-Level Voltage	$V_{IH}$	2.1	—	—	V	
Low-Level Voltage	$V_{IL}$	—	—	0.8	V	
Input Current	$I_{IN}$	—	—	$\pm 5$	$\mu A$	
<b>Output (SDA)</b>						
Low-Level Voltage	$V_{OL}$	—	—	0.4	V	$I_{OL} = 3\text{ mA}$
High-Level Current (leakage)	$I_{OH}$	—	—	1	$\mu A$	$V_{OH} = 3.6V$
Low-Level Current	$I_{OL}$	6	—	—	mA	$V_{OL} = 0.6V$
Capacitance	$C_{IN}$	—	5	—	pF	
<b>SDA and SCLK Inputs</b>						
Hysteresis	$V_{HYST}$	—	0.5	—	V	

### Graphical Symbol Description



# MCP9805

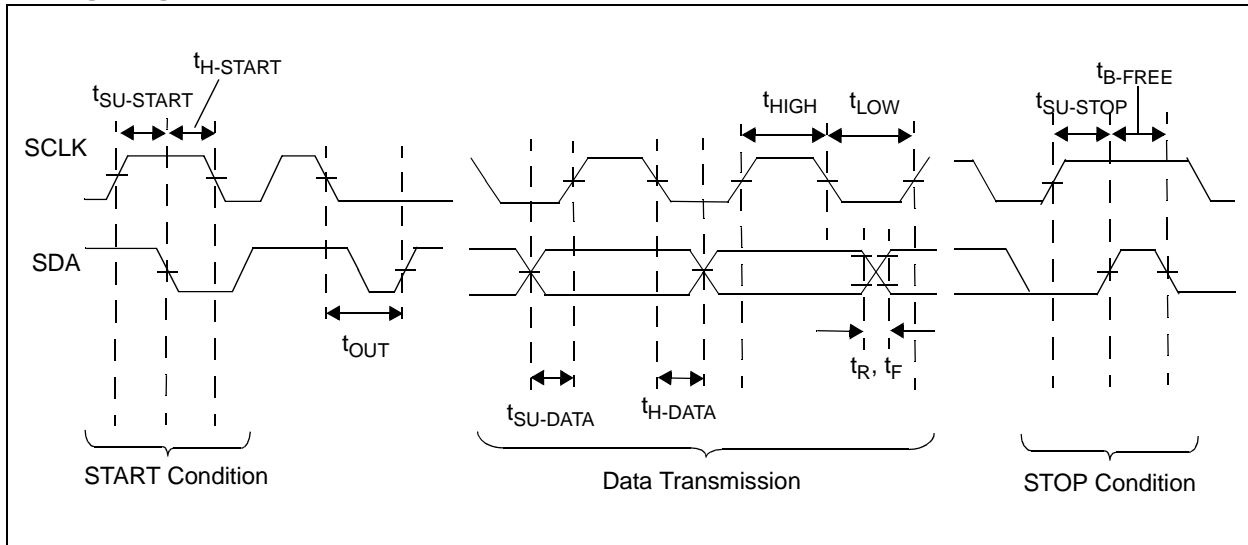
## SERIAL INTERFACE TIMING CHARACTERISTICS

**Electrical Specifications:** Unless otherwise indicated,  $V_{DD} = 3.0V$  to  $3.6V$ , GND = Ground,  $T_A = -20^{\circ}C$  to  $+125^{\circ}C$ ,  $C_L = 80$  pF and all limits measured to 50% point.

Parameters	Sym	Min	Typ	Max	Units	Conditions
<b>2-Wire SMBus/Standard Mode I<sup>2</sup>C™ Compatible Interface (Note)</b>						
Serial Port Clock Frequency	$f_{SC}$	10	—	100	kHz	
Low Clock	$t_{LOW}$	4.7	—	—	$\mu s$	
High Clock	$t_{HIGH}$	4.0	—	—	$\mu s$	
Rise Time	$t_R$	—	—	1000	ns	$(V_{IL\ MAX} - 0.15V)$ to $(V_{IH\ MIN} + 0.15V)$
Fall Time	$t_F$	—	—	300	ns	$(V_{IH\ MIN} + 0.15V)$ to $(V_{IL\ MAX} - 0.15V)$
Data Setup Before SCLK High	$t_{SU-DATA}$	250	—	—	ns	
Data Hold After SCLK Low	$t_{HD-DATA}$	300	—	—	ns	
Start Condition Setup Time	$t_{SU-START}$	4.7	—	—	$\mu s$	
Start Condition Hold Time	$t_{HD-START}$	4.0	—	—	$\mu s$	
Stop Condition Setup Time	$t_{SU-STOP}$	4.0	—	—	$\mu s$	
Bus Free	$t_{B-FREE}$	4.7	—	—	$\mu s$	
Time Out	$t_{OUT}$	25	40	50	ms	

**Note:** The serial interface specification min./max. limits are specified by characterization (not production tested).

### Timing Diagram



## TEMPERATURE CHARACTERISTICS

**Electrical Specifications:** Unless otherwise indicated,  $V_{DD} = 3.0V$  to  $3.6V$ , GND = Ground.

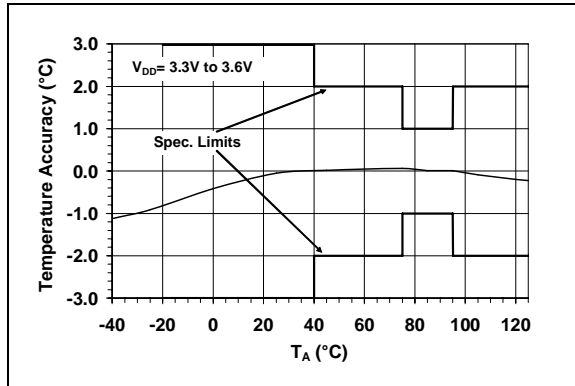
Parameters	Sym	Min	Typ	Max	Units	Conditions
<b>Temperature Ranges</b>						
Specified Temperature Range	$T_A$	-20	—	+125	$^{\circ}C$	
Operating Temperature Range	$T_A$	-40	—	+125	$^{\circ}C$	<b>Note 1</b>
Storage Temperature Range	$T_A$	-65	—	+150	$^{\circ}C$	
<b>Thermal Package Resistances</b>						
Thermal Resistance, 8L-DFN	$\theta_{JA}$	—	41	—	$^{\circ}C/W$	
Thermal Resistance, 8L-TSSOP	$\theta_{JA}$	—	123.7	—	$^{\circ}C/W$	

**Note 1:** Operation in this range must not cause  $T_J$  to exceed Maximum Junction Temperature ( $+150^{\circ}C$ ).

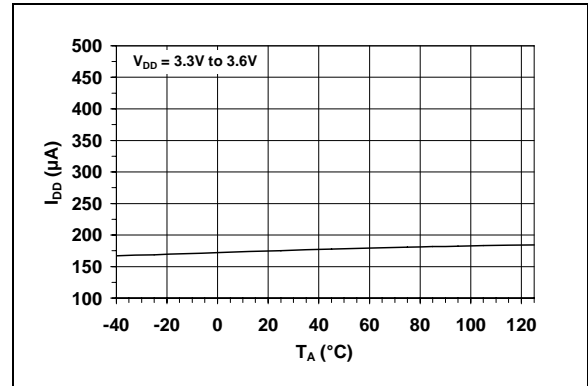
## 2.0 TYPICAL PERFORMANCE CURVES

**Note:** The graphs and tables provided following this note are a statistical summary based on a limited number of samples and are provided for informational purposes only. The performance characteristics listed herein are not tested or guaranteed. In some graphs or tables, the data presented may be outside the specified operating range (e.g., outside specified power supply range) and therefore outside the warranted range.

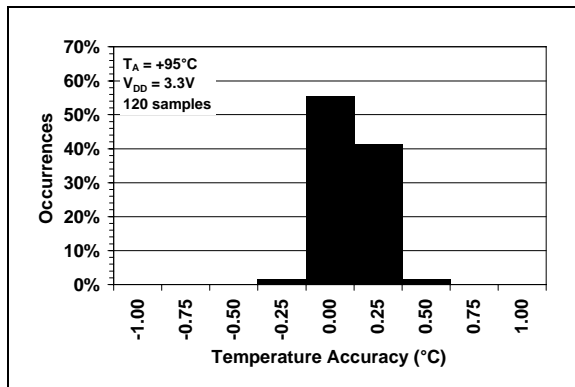
**Note:** Unless otherwise noted:  $V_{DD} = 3.0V$  to  $3.6V$ , GND = Ground,  $C_{de\_cap} = 0.1 \mu F$



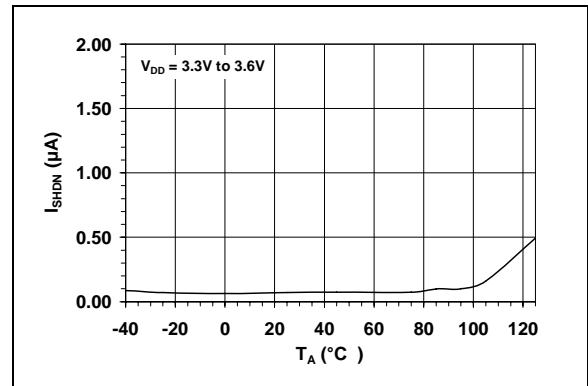
**FIGURE 2-1:** Average Temperature Accuracy.



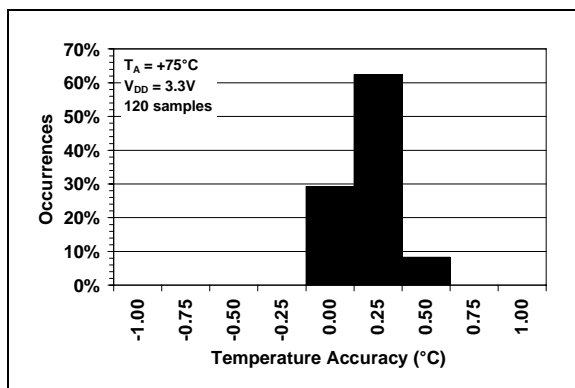
**FIGURE 2-4:** Supply Current vs. Ambient Temperature.



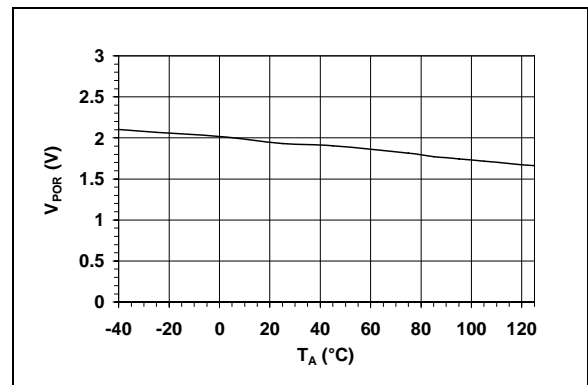
**FIGURE 2-2:** Temperature Accuracy Histogram,  $T_A = +95^\circ C$ .



**FIGURE 2-5:** Shutdown Current vs. Ambient Temperature.



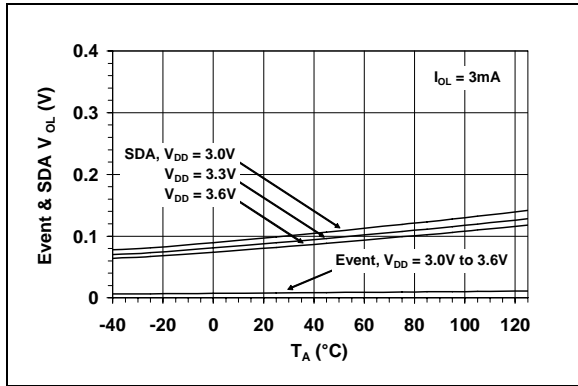
**FIGURE 2-3:** Temperature Accuracy Histogram,  $T_A = +75^\circ C$ .



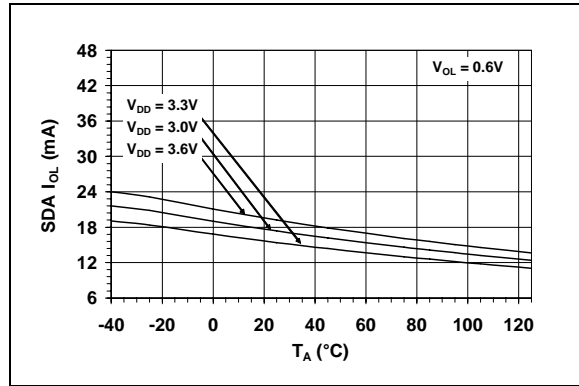
**FIGURE 2-6:** Power-on Reset Threshold Voltage vs. Ambient Temperature.

# MCP9805

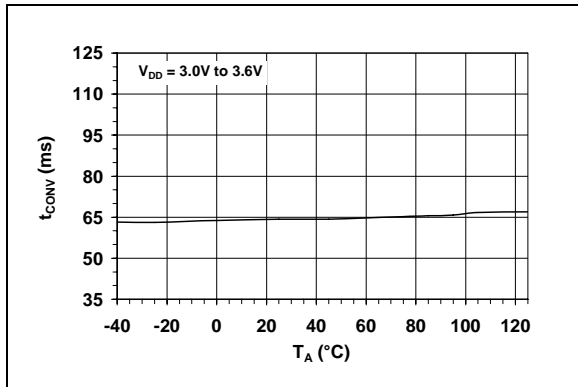
**Note:** Unless otherwise noted:  $V_{DD} = 3.0V$  to  $3.6V$ , GND = Ground,  $C_{de\_cap} = 0.1 \mu F$ .



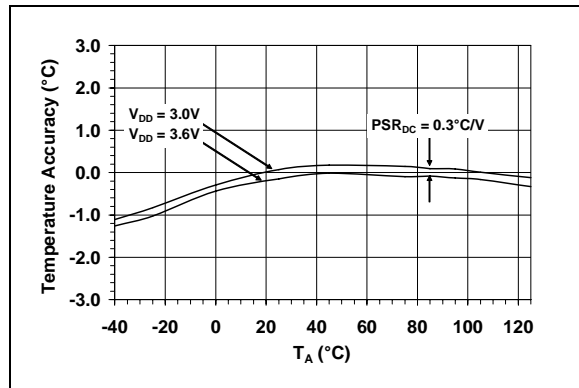
**FIGURE 2-7:** Event and SDA  $V_{OL}$  vs. Ambient Temperature.



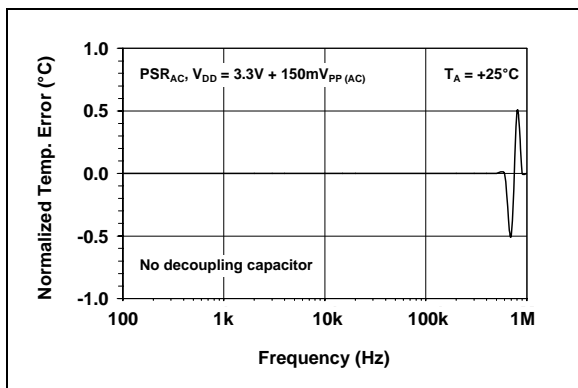
**FIGURE 2-10:** SDA  $I_{OL}$  vs. Ambient Temperature.



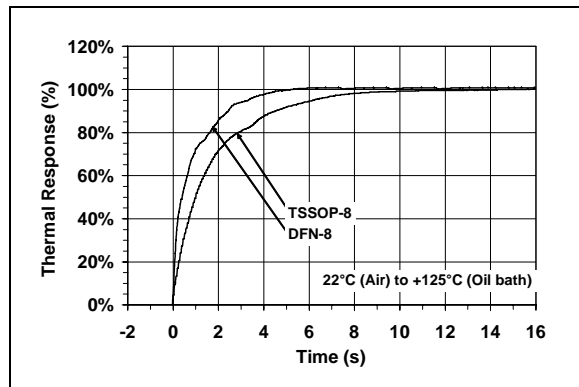
**FIGURE 2-8:** Conversion Rate vs. Ambient Temperature.



**FIGURE 2-11:** Temperature Accuracy vs.  $V_{DD}$ .



**FIGURE 2-9:** Power Supply Rejection vs. Frequency.



**FIGURE 2-12:** Package Thermal Response.

## 3.0 PIN DESCRIPTION

The descriptions of the pins are listed in Table 3-1.

**TABLE 3-1: PIN FUNCTION TABLES**

DFN/TSSOP	Symbol	Pin Function
1	A0	Slave Address
2	A1	Slave Address
3	A2	Slave Address
4	GND	Ground
5	SDA	Serial Data Line
6	SCLK	Serial Clock Line
7	Event	Temperature Event Output
8	V <sub>DD</sub>	Power

### 3.1 Slave Address Pins (A0, A1, A2 )

A0, A1 and A2 are device slave address input pins.

The address pins correspond to the Least Significant bits (LSBs) of the address byte (see **Section 5.1.4 “Address Byte”**). The Most Significant bits A6, A5, A4, A3 are factory set. This is shown in Table 3-2.

**TABLE 3-2: MCP9805 ADDRESS BYTE**

Device	Address Code				Slave Address		
	A6	A5	A4	A3	A2	A1	A0
MCP9805	0	0	1	1	X	X	X

**Note:** User-selectable address is shown by X.

### 3.2 Ground Pin (GND)

The GND pin is the system ground pin.

### 3.3 Open-Drain Serial Data Line (SDA)

SDA is a bidirectional input/output pin, used to serially transmit data to/from the host controller. This pin requires a pull-up resistor. (See **Section 5.0 “Serial Communication”**).

### 3.4 Open-Drain Serial Clock Line (SCLK)

The SCLK is a clock input pin. All communication and timing is relative to the signal on this pin. The clock is generated by the host or master controller on the bus. (See **Section 5.0 “Serial Communication”**).

### 3.5 Open-Drain Temperature Event Output pin (Event)

The MCP9805 Event pin is an open-drain output. The device outputs a signal when the ambient temperature goes beyond the user-programmed temperature limit. (see **Section 4.2.3 “Event Output Configuration”**).

### 3.6 Power Pin (V<sub>DD</sub>)

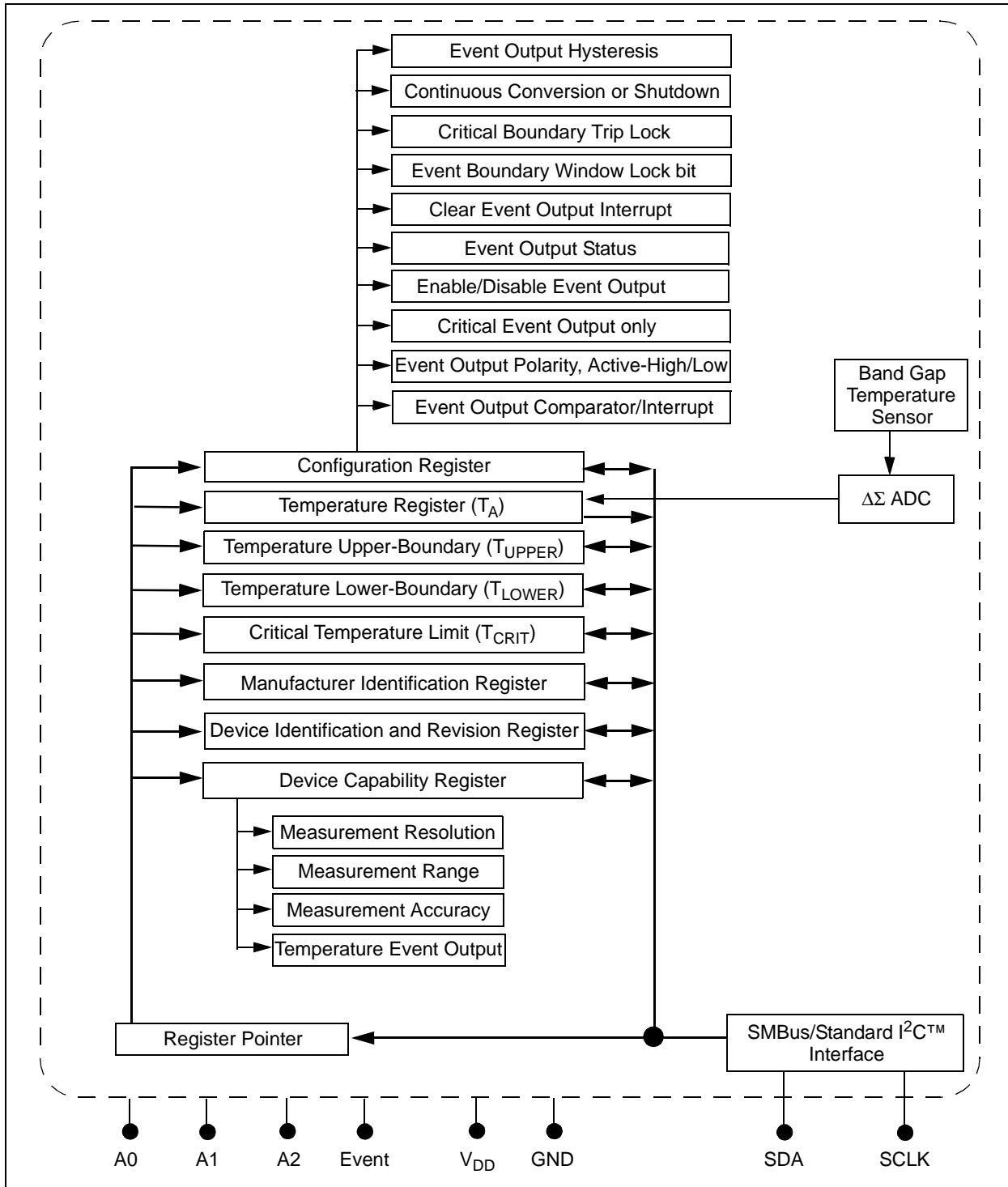
V<sub>DD</sub> is the power pin. The operating voltage range, as specified in the DC electrical specification table, is applied on this pin.

# MCP9805

## 4.0 FUNCTIONAL DESCRIPTION

The MCP9805 temperature sensors consist of a band gap temperature sensor, a Delta-Sigma Analog-to-Digital Converter ( $\Delta\Sigma$  ADC) and user-programmable registers using a 2-wire

SMBus/Standard mode I<sup>2</sup>C compatible serial interface protocol. Figure 4-1 shows a block diagram of the register structure.



**FIGURE 4-1:** Register Structure Block Diagram.



## 4.1 Registers

The MCP9805 has several registers that are user-accessible. These registers include the Capability register, Configuration register, Event Temperature Upper-Boundary and Lower-Boundary Trip registers, Critical Temperature Trip register, Temperature register, Manufacturer Identification register and Device Identification register.

The Temperature register is read-only, used to access the ambient temperature data. The data is loaded in parallel to this register after  $t_{CONV}$ . The Event Temperature Upper-Boundary and Lower-Boundary Trip registers are read/writes. If the ambient temperature drifts beyond the user-specified limits, the MCP9805 outputs a signal using the Event pin (refer to **Section 4.2.3 “Event Output Configuration”**). In addition, the Critical Temperature Trip register is used to provide an additional critical temperature limit.

The Capability register is used to provide bits describing the MCP9805's capability in measurement resolution, measurement range and device accuracy. The device Configuration register provides access to configure the MCP9805's various features. These registers are described in further detail in the following sections.

The registers are accessed by sending a Register Pointer to the MCP9805 using the serial interface. This is an 8-bit write-only pointer. However, the three Least Significant bits (3-LSBs) are used as pointers and all unused bits (bits 7-3) need to be cleared or set to '0'. Register 4-1 describes the pointer or the address of each register.

### REGISTER 4-1: REGISTER ADDRESS POINTER (WRITE-ONLY)

W-0	W-0	W-0	W-0	W-0	W-0	W-0	W-0
0	0	0	0	0	P2	P1	P0
bit 7						bit 0	

bit 7-3 **Writable Bits:** Write '0'

Bits 7-3 must always be cleared or written to '0'. This device has additional registers that are reserved for test and calibration. If these registers are accessed, the device may not perform according to the specification.

bit 2-0 **Pointer Bits:**

- 000 = Capability register
- 001 = Configuration register (CONFIG)
- 010 = Event Temperature Upper-Boundary Trip register ( $T_{UPPER}$ )
- 011 = Event Temperature Lower-Boundary Trip register ( $T_{LOWER}$ )
- 100 = Critical Temperature Trip register ( $T_{CRIT}$ )
- 101 = Temperature register ( $T_A$ )
- 110 = Manufacturer ID register
- 111 = Device ID/Revision register

#### Legend:

R = Readable bit	W = Writable bit	U = Unimplemented bit, read as '0'
- n = Value at POR	'1' = Bit is set	'0' = Bit is cleared    x = Bit is unknown

# MCP9805

## 4.1.1 CAPABILITY REGISTER

This is a read-only register used to identify the temperature sensor capability. In this case, the MCP9805 is capable of providing temperature at 0.25°C resolution, measuring temperature below and above 0°C, providing ±1°C and ±2°C accuracy over the active and monitor temperature ranges (respectively) and providing user-programmable temperature event boundary trip limits. Register 4-2 describes the Capability register. These functions are described in further detail in the following sections.

### REGISTER 4-2: CAPABILITY REGISTER (READ-ONLY) → ADDRESS '0000 0000'b

Upper-Half:							
U-0	U-0	U-0	U-0	U-0	U-0	U-0	U-0
—	—	—	—	—	—	—	—
bit 15				bit 8			

Lower-Half:							
U-0	U-0	U-0	R-0	R-1	R-1	R-1	R-1
—			Resolution		Meas. Range	Accuracy	Temp. Event
bit 7				bit 0			

bit 15-5 **Unimplemented:** Read as '0'

bit 4-3 **RESOLUTION bits:**

- 00 = 0.5 °C/LSb
- 01 = 0.25 °C/LSb (default resolution)
- 10 = 0.125 °C/LSb
- 11 = 0.0625 °C/LSb

bit 2 **TEMPERATURE MEASUREMENT RANGE (Meas. Range) bit:**

- 0 =  $T_A = 0x0000$  (Hexadecimal) for temperature below 0°C
- 1 = The part can measure temperature below 0°C

bit 1 **ACCURACY bit:**

- 0 = Accuracy → ±2°C from +75°C to +95°C (Active Range) and ±3°C from +40°C to +125°C (Monitor Range)
- 1 = Accuracy → ±1°C from +75°C to +95°C (Active Range) and ±2°C from +40°C to +125°C (Monitor Range)

bit 0 **BASIC CAPABILITY (Temp. Event) bit:**

- 0 = No defined function (This bit will never be cleared or set to '0').
- 1 = The part has temperature boundary trip limits ( $T_{UPPER}/T_{LOWER}/T_{CRIT}$  registers) and a temperature event output (JC 42.4 required feature).

#### Legend:

R = Readable bit	W = Writable bit	U = Unimplemented bit, read as '0'
- n = Value at POR	'1' = Bit is set	'0' = Bit is cleared      x = Bit is unknown

## 4.1.2 SENSOR CONFIGURATION REGISTER (CONFIG)

The MCP9805 has a 16-bit Configuration register (CONFIG) that allows the user to set various functions for a robust temperature monitoring system. Bits 10 thru 0 are used to select Event output boundary hysteresis, device Shutdown or Low-Power mode, temperature boundary and critical temperature lock, temperature Event output enable/disable. In addition, the user can select the Event output condition (output set for  $T_{UPPER}$  and  $T_{LOWER}$  temperature boundary or  $T_{CRIT}$  only), read Event output status and set Event output polarity and mode (Comparator Output or Interrupt Output mode).

The temperature hysteresis bits 10 and 9 can be used to prevent output chatter when the ambient temperature gradually changes beyond the user-specified temperature boundary (see **Section 4.2.2 “Temperature Hysteresis ( $T_{HYST}$ )”**). The Continuous Conversion or Shutdown mode is selected using bit 8. In Shutdown mode, the band gap temperature sensor circuit stops converting temperature and the Ambient Temperature register ( $T_A$ ) holds the previous successfully converted temperature data (see **Section 4.2.1 “Shutdown Mode”**). Bits 7 and 6 are used to lock the user-specified boundaries  $T_{UPPER}$ ,  $T_{LOWER}$  and  $T_{CRIT}$  to prevent an accidental rewrite. Bits 5 thru 0 are used to configure the temperature Event output pin. All functions are described in Register 4-3 (see **Section 4.2.3 “Event Output Configuration”**).

### REGISTER 4-3: CONFIGURATION REGISTER (CONFIG) → ADDRESS ‘0000 0001’b

Upper-Half:							
U-0	U-0	U-0	U-0	U-0	R/W-0	R/W-0	R/W-0
—	—	—	—	—	$T_{HYST}$		SHDN
bit 15					bit 8		

Lower-Half:							
R/W-0	R/W-0	R/W-0	R-0	R/W-0	R/W-0	R/W-0	R/W-0
Crit. Lock	Win. Lock	Int. Clear	Event Stat.	Event Cnt.	Event Sel.	Event Pol.	Event Mod.
bit 7							bit 0

bit 15-11 **Unimplemented:** Read as ‘0’

bit 10-9 **Limit Hysteresis ( $T_{HYST}$ ) bits:**

00 = 0°C (power-up default)

01 = 1.5°C

10 = 3.0°C

11 = 6.0°C

(Refer to **Section 4.2.3 “Event Output Configuration”**)

bit 8 **Shutdown Mode (SHDN) bit:**

0 = Continuous Conversion (power-up default)

1 = Shutdown (Low-Power mode)

In shutdown, all power-consuming activities are disabled, though all registers can be written to or read.

This bit cannot be set ‘1’ when either of the lock bits is set (bit 6 and bit 7). However, it can be cleared ‘0’ for Continuous Conversion while locked. (Refer to **Section 4.2.1 “Shutdown Mode”**)

bit 7  **$T_{CRIT}$  Lock Bit (Crit. Lock) bit:**

0 = Unlocked.  $T_{CRIT}$  register can be written. (power-up default)

1 = Locked.  $T_{CRIT}$  register cannot be written to.

When enabled, this bit remains set ‘1’ or locked until cleared by internal reset (**Section 4.3 “Summary of Power-up Default”**). This bit does not require a double-write.

#### Legend:

R = Readable bit

W = Writable bit

U = Unimplemented bit, read as ‘0’

- n = Value at POR

‘1’ = Bit is set

‘0’ = Bit is cleared

x = Bit is unknown

# MCP9805

## REGISTER 4-3: CONFIGURATION REGISTER (CONFIG) → ADDRESS '0000 0001'b (CONTINUED)

Upper-Half:							
U-0	U-0	U-0	U-0	U-0	R/W-0	R/W-0	R/W-0
—	—	—	—	—	T <sub>HYST</sub>		SHDN
bit 15						bit 8	

Lower-Half:								
R/W-0	R/W-0	R/W-0	R-0	R/W-0	R/W-0	R/W-0	R/W-0	R/W-0
Crit. Lock	Win. Lock	Int. Clear	Event Stat.	Event Cnt.	Event Sel.	Event Pol.	Event Mod.	
bit 7								bit 0

- bit 6 **T<sub>UPPER</sub> and T<sub>LOWER</sub> Boundary Window Lock (Win. Lock) bit:**  
 0 = Unlocked. T<sub>UPPER</sub> and T<sub>LOWER</sub> registers can be written. (power-up default)  
 1 = Locked. T<sub>UPPER</sub> and T<sub>LOWER</sub> registers cannot be written.  
 When enabled, this bit remains set '1' or locked until cleared by internal reset (**Section 4.3 "Summary of Power-up Default"**). This bit does not require a double-write.
- bit 5 **Interrupt Clear (Int. Clear) bit:**  
 0 = No effect. (power-up default)  
 1 = Clear interrupt output. When read this bit returns '0'.
- bit 4 **Event Output Status (Event Stat.) bit:**  
 0 = Event output is not asserted by the device. (power-up default)  
 1 = Event output is asserted as a comparator/interrupt or critical temperature output.
- bit 3 **Event Output Control (Event Cnt.) bit:**  
 0 = Disabled. (power-up default)  
 1 = Enabled.  
 This bit can not be altered when either of the lock bits is set (bit 6 and bit 7).
- bit 2 **Event Output Select (Event Sel.) bit:**  
 0 = Event output for T<sub>UPPER</sub>, T<sub>LOWER</sub> and T<sub>CRIT</sub>. (power-up default)  
 1 = T<sub>A</sub> ≥ T<sub>CRIT</sub> only. (T<sub>UPPER</sub> and T<sub>LOWER</sub> temperature boundaries are disabled.)  
 When the Alarm Window Lock bit is set '1' (bit 6), this bit cannot be altered until unlocked.
- bit 1 **Event Output Polarity (Event Pol.) bit:**  
 0 = Active-low. (power-up default)  
 1 = Active-high.  
 This bit cannot be altered when either of the lock bits is set (bit 6 and bit 7).
- bit 0 **Event Output Mode (Event Mod.) bit:**  
 0 = Comparator output. (power-up default)  
 1 = Interrupt output.  
 This bit cannot be altered when either of the lock bits is set (bit 6 and bit 7).

Legend:			
R = Readable bit	W = Writable bit	U = Unimplemented bit, read as '0'	
- n = Value at POR	'1' = Bit is set	'0' = Bit is cleared	x = Bit is unknown

## 4.1.3 TEMPERATURE EVENT UPPER/LOWER/CRITICAL BOUNDARY TRIP REGISTERS ( $T_{UPPER}/T_{LOWER}/T_{CRIT}$ )

The MCP9805 has a 16-bit read/write Event output Temperature Upper-Boundary Trip register ( $T_{UPPER}$ ), a 16-bit Lower-Boundary Trip register ( $T_{LOWER}$ ) and a 16-bit Critical Boundary Trip register ( $T_{CRIT}$ ) that contains 11-bit data in two's complement format (0.25 °C/LSb). This data represents the maximum and minimum temperature boundary or temperature window that can be used to monitor ambient temperature. If this feature is enabled (Section 4.1.2 "Sensor Configuration Register (CONFIG)") and the ambient temperature exceeds the specified boundary or window, the MCP9805 asserts an Event output. (Refer to Section 4.2.3 "Event Output Configuration").

### REGISTER 4-4: UPPER/LOWER/CRITICAL TEMPERATURE BOUNDARY TRIP REGISTERS ( $T_{UPPER}/T_{LOWER}/T_{CRIT}$ ) → ADDRESS '0000 0010'b/'0000 0011'b/'0000 0100'b

Upper-Half:							
U-0	U-0	U-0	R/W-0	R/W-0	R/W-0	R/W-0	R/W-0
—	—	—	SIGN	$2^7$ °C/LSb	$2^6$ °C/LSb	$2^5$ °C/LSb	$2^4$ °C/LSb
bit 15			bit 8				

Lower-Half:							
R/W-0	R/W-0	R/W-0	R/W-0	R/W-0	R/W-0	U-0	U-0
$2^3$ °C/LSb	$2^2$ °C/LSb	$2^1$ °C/LSb	$2^0$ °C/LSb	$2^{-1}$ °C/LSb	$2^{-2}$ °C/LSb	—	—
bit 7						bit 0	

bit 15-13 **Unimplemented:** Read as '0'

bit 12 **SIGN bit:**  
 0 =  $T_A \geq 0^\circ\text{C}$   
 1 =  $T_A < 0^\circ\text{C}$

bit 11-2  **$T_{UPPER}/T_{LOWER}/T_{CRIT}$  bits:**  
 Temperature boundary trip data in two's complement format.

bit 1-0 **Unimplemented:** Read as '0'

**Note:** This table reflects the three 16-bit registers  $T_{UPPER}$ ,  $T_{LOWER}$  and  $T_{CRIT}$  located at address '0000 0010'b, '0000 0011'b and '0000 0100'b, respectively (see Register 4-1).

Legend:			
R = Readable bit	W = Writable bit	U = Unimplemented bit, read as '0'	
-n = Value at POR	'1' = bit is set	'0' = bit is cleared	x = bit is unknown

# MCP9805

## 4.1.4 AMBIENT TEMPERATURE REGISTER (T<sub>A</sub>)

The MCP9805 uses a band gap temperature sensor circuit to output analog voltage proportional to absolute temperature. An internal  $\Delta\Sigma$  ADC is used to convert the analog voltage to a digital word. The converter resolution is set to 0.25 °C/LSb + sign (11-bit data). The digital word is loaded to a 16-bit read-only Ambient Temperature register (T<sub>A</sub>) that contains 11-bit temperature data in two's complement format.

The T<sub>A</sub> register bits (bits 12 thru 0) are double-buffered. Therefore, the user can access the register while, in the background, the MCP9805 performs an analog-to-digital conversion of the band gap temperature sensor. The temperature data from the  $\Delta\Sigma$  ADC is loaded in parallel to T<sub>A</sub> at t<sub>CONV</sub> refresh rate.

The T<sub>A</sub> magnitude in decimal to ambient temperature conversion is shown in Equation 4-1:

## EQUATION 4-1: DECIMAL CODE TO TEMPERATURE CONVERSION

$$T_A = Code \times 2^{-2}$$

Where:

T<sub>A</sub> = Ambient Temperature (°C)  
Code = MCP9805 output magnitude in decimal

In addition, the T<sub>A</sub> register uses three bits (bits 15, 14 and 13) to reflect the Event pin state. This allows the user to identify the cause of the Event output trigger (see **Section 4.2.3 “Event Output Configuration”**); bit 15 is set to ‘1’ if T<sub>A</sub> is greater than or equal to T<sub>CRIT</sub>; bit 14 is set to ‘1’ if T<sub>A</sub> is greater than T<sub>UPPER</sub> and bit 13 is set to ‘1’ if T<sub>A</sub> is less than T<sub>LOWER</sub>.

The T<sub>A</sub> register bit assignment and boundary conditions are described in Register 4-5.

## REGISTER 4-5: AMBIENT TEMPERATURE REGISTER (T<sub>A</sub>) → ADDRESS ‘0000 0101’b

Upper-Half:							
R-0	R-0	R-0	R-0	R-0	R-0	R-0	R-0
T <sub>A</sub> Vs. T <sub>CRIT</sub>	T <sub>A</sub> Vs. T <sub>UPPER</sub>	T <sub>A</sub> Vs. T <sub>LOWER</sub>	SIGN	2 <sup>7</sup> °C/LSb	2 <sup>6</sup> °C/LSb	2 <sup>5</sup> °C/LSb	2 <sup>4</sup> °C/LSb
bit 15							bit 8

Lower-Half:							
R-0	R-0	R-0	R-0	R-0	R-0	U-0	U-0
2 <sup>3</sup> °C/LSb	2 <sup>2</sup> °C/LSb	2 <sup>1</sup> °C/LSb	2 <sup>0</sup> °C/LSb	2 <sup>-1</sup> °C/LSb	2 <sup>-2</sup> °C/LSb	— <sup>(2)</sup>	—
bit 7							bit 0

bit 15 **T<sub>A</sub> vs. T<sub>CRIT</sub><sup>(1)</sup> bit:**

0 = T<sub>A</sub> < T<sub>CRIT</sub>  
1 = T<sub>A</sub> ≥ T<sub>CRIT</sub>

bit 14 **T<sub>A</sub> vs. T<sub>UPPER</sub><sup>(1)</sup> bit:**

0 = T<sub>A</sub> ≤ T<sub>UPPER</sub>  
1 = T<sub>A</sub> > T<sub>UPPER</sub>

bit 13 **T<sub>A</sub> vs. T<sub>LOWER</sub><sup>(1)</sup> bit:**

0 = T<sub>A</sub> ≥ T<sub>LOWER</sub>  
1 = T<sub>A</sub> < T<sub>LOWER</sub>

bit 12 **SIGN bit:**

0 = T<sub>A</sub> ≥ 0°C  
1 = T<sub>A</sub> < 0°C

**Note 1:** Not affected by the status of the Event output configuration (bits 5 to 0 of CONFIG) and T<sub>HYST</sub> = 0°C, Register 4-3.

**2:** Bit 1 may remain set ‘1’ for some devices indicating 2<sup>-3</sup> °C/LSb or 0.125°C temperature resolution, depending on the state of the device calibration code.

### Legend:

R = Readable bit  
-n = Value at POR

W = Writable bit  
‘1’ = bit is set

U = Unimplemented bit, read as ‘0’  
‘0’ = bit is cleared  
x = bit is unknown

**REGISTER 4-5: AMBIENT TEMPERATURE REGISTER ( $T_A$ ) → ADDRESS '0000 0101'b  
(CONTINUED)**

Upper-Half:							
R-0	R-0	R-0	R-0	R-0	R-0	R-0	R-0
$T_A$ Vs. $T_{CRIT}$	$T_A$ Vs. $T_{UPPER}$	$T_A$ Vs. $T_{LOWER}$	SIGN	$2^7$ °C/LSb	$2^6$ °C/LSb	$2^5$ °C/LSb	$2^4$ °C/LSb
bit 15							bit 8

Lower-Half:							
R-0	R-0	R-0	R-0	R-0	R-0	U-0	U-0
$2^3$ °C/LSb	$2^2$ °C/LSb	$2^1$ °C/LSb	$2^0$ °C/LSb	$2^{-1}$ °C/LSb	$2^{-2}$ °C/LSb	— <sup>(2)</sup>	—
bit 7						bit 0	

bit 11-2 **Ambient Temperature ( $T_A$ ) bits:**

10-bit Ambient Temperature data in two's complement format.

bit 1, 0 **Unimplemented:** Read as '0' (**Note 2**)

**Note 1:** Not affected by the status of the Event output configuration (bits 5 to 0 of CONFIG) and  $T_{HYST} = 0^\circ\text{C}$ , Register 4-3.

**2:** Bit 1 may remain set '1' for some devices indicating  $2^{-3}$  °C/LSb or 0.125°C temperature resolution, depending on the state of the device calibration code.

Legend:			
R = Readable bit	W = Writable bit	U = Unimplemented bit, read as '0'	
-n = Value at POR	'1' = bit is set	'0' = bit is cleared	x = bit is unknown

# MCP9805

## 4.1.5 MANUFACTURER ID REGISTER

This register is used to identify the device manufacturer in order to perform manufacturer-specific operations. The manufacturer ID for the MCP9805 is 0x0054 (hexadecimal).

### REGISTER 4-1: MANUFACTURER ID REGISTER (READ-ONLY) → ADDRESS '0000 0110'b

<b>Upper-Half:</b>							
R-0	R-0	R-0	R-0	R-0	R-0	R-0	R-0
Manufacturer ID							
bit 15				bit 8			

<b>Lower-Half:</b>							
R-0	R-1	R-0	R-1	R-0	R-1	R-0	R-0
Manufacturer ID							
bit 7				bit 0			

<b>Legend:</b>			
R = Readable bit	W = Writable bit	U = Unimplemented bit, read as '0'	
- n = Value at POR	'1' = Bit is set	'0' = Bit is cleared	x = Bit is unknown

## 4.1.6 DEVICE ID AND REVISION REGISTER

The upper byte of this register is used to specify the device identification and the lower byte is used to specify device revision. The device ID for the MCP9805 is 0x00 (hex).

The revision begins with 0x00 (hex) for the first release, with the number being incremented as revised versions are released.

### REGISTER 4-2: DEVICE ID AND DEVICE REVISION (READ-ONLY) → ADDRESS '0000 0111'b

<b>Upper-Half:</b>							
R-0	R-0	R-0	R-0	R-0	R-0	R-0	R-0
Device ID							
bit 15				bit 8			

<b>Lower-Half:</b>							
R-0	R-0	R-0	R-0	R-0	R-0	R-0	R-0
Device Revision							
bit 7				bit 0			

<b>Legend:</b>			
R = Readable bit	W = Writable bit	U = Unimplemented bit, read as '0'	
- n = Value at POR	'1' = Bit is set	'0' = Bit is cleared	x = Bit is unknown



## 4.2 Sensor Feature Description

### 4.2.1 SHUTDOWN MODE

Shutdown mode disables all power-consuming activities (including temperature sampling operations) while leaving the serial interface active. This mode is selected by setting bit 8 of CONFIG to '1'. In this mode, the device consumes  $I_{SHDN}$ . It remains in this mode until bit 8 is cleared '0' to enable Continuous Conversion mode, or until power is recycled.

The Shutdown bit (bit 8) cannot be set to '1' while bits 6 and 7 of CONFIG (Lock bits) are set to '1'. However, it can be cleared '0' or returned to Continuous Conversion while locked.

In Shutdown mode, all registers can be read or written. However, the serial bus activity increases the shutdown current. In addition, if the device is shutdown while the Event pin is asserted as active-low or deasserted active-low (see **Section 4.2.3.1 "Comparator Mode"** and **Section 4.2.3.2 "Interrupt Mode"**), the device will retain the active-low state. This increases the shutdown current due to the additional Event output pull-down current.

### 4.2.2 TEMPERATURE HYSTERESIS ( $T_{HYST}$ )

A hysteresis of 0°C, 1.5°C, 3°C or 6°C can be selected for the  $T_{UPPER}$ ,  $T_{LOWER}$  and  $T_{CRIT}$  temperature boundaries using bits 10 and 9 of CONFIG. The hysteresis applies for decreasing temperature only (hot to cold), or as temperature drifts below the specified limit.

The  $T_{UPPER}$ ,  $T_{LOWER}$  and  $T_{CRIT}$  boundary conditions are described graphically in Figure 4-2.

### 4.2.3 EVENT OUTPUT CONFIGURATION

The Event output can be enabled using bit 3 of CONFIG (Event output control bit) and can be configured as either a comparator output or as Interrupt Output mode using bit 0 of CONFIG (Event mode). The polarity can also be specified as an active-high or active-low using bit 1 of CONFIG (Event polarity).

When the ambient temperature increases above the critical temperature limit, the Event output is forced to a comparator output (regardless of bit 0 of CONFIG). When the temperature drifts below the critical temperature limit, the Event output automatically returns to the state specified by bit 0 of CONFIG.

The status of the Event output can be read using bit 4 of CONFIG (Event status).

Bit 7 and 6 of the CONFIG register can be used to lock the  $T_{UPPER}$ ,  $T_{LOWER}$  and  $T_{CRIT}$  registers. The bits prevent false triggers at the Event output due to an accidental rewrite to these registers.

The Event output can also be used as a critical temperature output using bit 2 of CONFIG (critical output only). When this feature is selected, the Event output becomes a comparator output. In this mode, the interrupt output configuration (bit 0 of CONFIG) is ignored.

#### 4.2.3.1 Comparator Mode

Comparator mode is selected using bit 0 of CONFIG. In this mode, the Event output is asserted as active-high or active-low using bit 1 of CONFIG. Figure 4-2 shows the conditions that toggle the Event output.

If the device enters Shutdown mode with asserted Event output, the output remains asserted during Shutdown. The device must be operating in Continuous Conversion mode for  $t_{CONV}$ ; the  $T_A$  vs.  $T_{UPPER}$ ,  $T_{LOWER}$  and  $T_{CRIT}$  boundary conditions need to be satisfied in order for the Event output to deassert.

Comparator mode is useful for thermostat-type applications, such as turning on a cooling fan or triggering a system shutdown when the temperature exceeds a safe operating range.

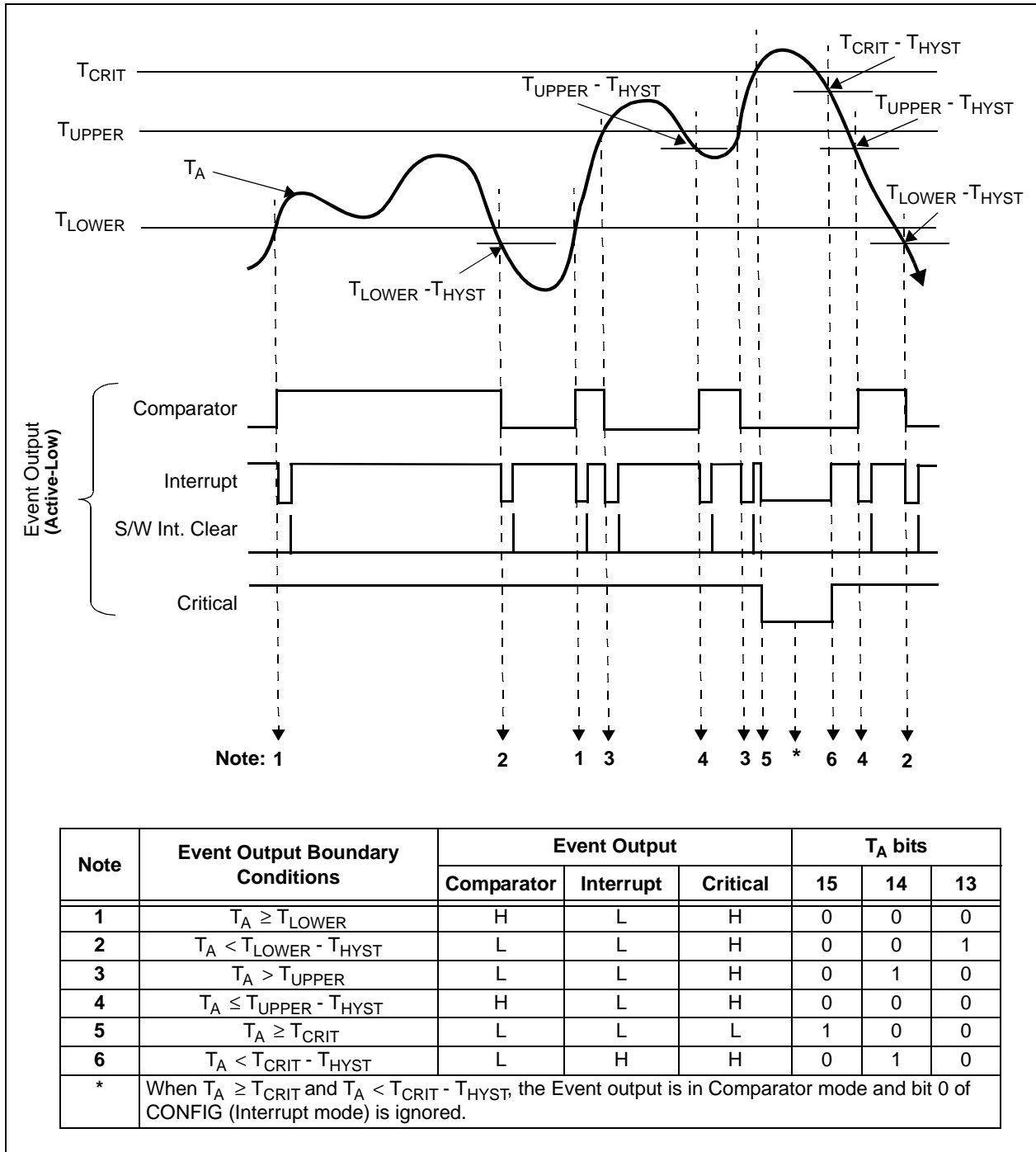
#### 4.2.3.2 Interrupt Mode

Interrupt mode is selected using bit 0 of CONFIG. In this mode, the Event output is asserted as active-high or active-low using bit 1 of CONFIG. The output is deasserted by setting '1' to bit 5 of CONFIG (interrupt clear). Shutting down the device will not reset or deassert the Event output. However, clearing the interrupt using bit 5 of CONFIG while in Shutdown mode will deassert the Event output.

This mode is ignored when the Event output is used as critical temperature output only (bit 2 of CONFIG).

Interrupt mode applies to interrupt-driven, microcontroller-based systems. The microcontroller receiving the interrupt will have to acknowledge the interrupt by setting '1' to bit 5 of CONFIG.

# MCP9805



**FIGURE 4-2:** Event Output Boundary Conditions.

## 4.3 Summary of Power-up Default

The MCP9805 has an internal Power-on Reset (POR) circuit. If the power supply voltage  $V_{DD}$  drifts below the  $V_{POR}$  threshold, the device resets the registers to the power-up default settings.

Table 4-6 shows the power-up default summary.

**TABLE 4-6: POWER-UP DEFAULTS**

Registers		Default Register Data (Hex)	Power-up Default Register Description
Address (Hex)	Register Label		
0x00	Capability	0x000F	0.25 °C/LSb Measures Temperature Below 0°C ±1°C Accuracy Over Active Range Basic Capability (Event output)
0x01	CONFIG	0x0000	Comparator Mode Active-Low Output Event and Critical output Output Enabled Event Not Asserted Interrupt Cleared Event Limits Unlocked Critical Limit Unlocked Continuous Conversion 0°C Hysteresis
0x02	T <sub>UPPER</sub>	0x0000	0°C
0x03	T <sub>LOWER</sub>	0x0000	0°C
0x04	T <sub>CRIT</sub>	0x0000	0°C
0x05	T <sub>A</sub>	0x0000	0°C
0x06	Manufacturer ID	0x0054	0x0054 (hex)
0x07	Device ID/Device Revision	0x0000	0x0000 (hex)

# MCP9805

## 5.0 SERIAL COMMUNICATION

### 5.1 2-Wire SMBus/Standard Mode I<sup>2</sup>C™ Protocol-Compatible Interface

The MCP9805 serial clock input (SCLK) and the bidirectional serial data line (SDA) form a 2-Wire bidirectional SMBus/Standard mode I<sup>2</sup>C compatible communication port (refer to the Digital Input/Output Pin Characteristics Table and Serial Interface Timing Characteristics Table).

The following bus protocol has been defined:

**TABLE 5-1: MCP9805 SERIAL BUS PROTOCOL DESCRIPTIONS**

Term	Description
Master	The device that controls the serial bus, typically a microcontroller.
Slave	The device addressed by the master, such as the MCP9805.
Transmitter	Device sending data to the bus.
Receiver	Device receiving data from the bus.
START	A unique signal from master to initiate serial interface with a slave.
STOP	A unique signal from the master to terminate serial interface from a slave.
Read/Write	A read or write to the MCP9805 registers.
ACK	A receiver Acknowledges (ACK) the reception of each byte by polling the bus.
NAK	A receiver Not-Acknowledges (NAK) or releases the bus to show End-of-Data (EOD).
Busy	Communication is not possible because the bus is in use.
Not Busy	The bus is in the idle state, both SDA and SCLK remain high.
Data Valid	SDA must remain stable before SCLK becomes high in order for a data bit to be considered valid. During normal data transfers, SDA only changes state while SCLK is low.

#### 5.1.1 DATA TRANSFER

Data transfers are initiated by a Start condition (START), followed by a 7-bit device address and a read/write bit. An Acknowledge (ACK) from the slave confirms the reception of each byte. Each access must be terminated by a Stop condition (STOP).

Repeated communication is initiated after  $t_{B-FREE}$ .

This device does not support sequential register read/write. Each register needs to be addressed using the Register Pointer.

This device supports the receive protocol. The register can be specified using the pointer for the initial read (see Figure 5-4). Each repeated read or receive can then be followed with a Start condition, followed by an address byte. The MCP9805 retains the previously selected register. Therefore, it expects a read from the previously-specified register (repeated pointer specification is not necessary).

#### 5.1.2 MASTER/SLAVE

The bus is controlled by a master device (typically a microcontroller) that controls the bus access and generates the Start and Stop conditions. The MCP9805 is a slave device and does not control other devices in the bus. Both master and slave devices can operate as either transmitter or receiver. However, the master device determines which mode is activated.

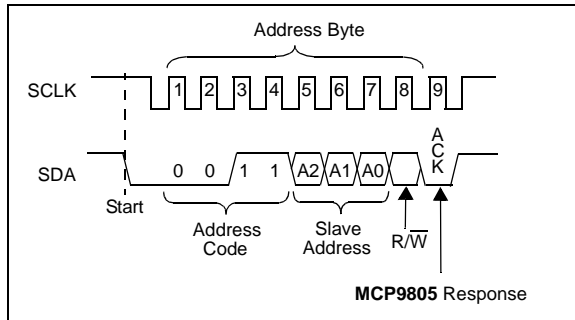
#### 5.1.3 START/STOP CONDITION

A high-to-low transition of the SDA line (while SCLK is high) is the Start condition. All data transfers must be preceded by a Start condition from the master. If a Start condition is generated during data transfer, the MCP9805 resets and accepts the new Start condition.

A low-to-high transition of the SDA line (while SCLK is high) signifies a Stop condition. If a Stop condition is introduced during data transmission, the MCP9805 releases the bus. All data transfers are ended by a Stop condition from the master. However, for continuous data reception from the previously-specified pointer (Register 4-1), a Start condition can be introduced at the end of data reception. The MCP9805 retains the previously-set pointer. Therefore, there is no need to repeat the pointer specification (see Register 5-4).

#### 5.1.4 ADDRESS BYTE

Following the Start condition, the host must transmit an 8-bit address byte to the MCP9805. The address for the MCP9805 is '0011, A<sub>2</sub>, A<sub>1</sub>, A<sub>0</sub>' in binary, where the A<sub>2</sub>, A<sub>1</sub> and A<sub>0</sub> bits are set externally by connecting the corresponding pins to V<sub>DD</sub> '1' or GND '0'. The 7-bit address transmitted in the serial bit stream must match the selected address for the MCP9805 to respond with an ACK. Bit 8 in the address byte is a read/write bit. Setting this bit to '1' commands a read operation, while '0' commands a write operation (see Figure 5-1).



**FIGURE 5-1:** Device Addressing.

## 5.1.5 DATA VALID

After the Start condition, each bit of data in transmission needs to be settled for a time specified by  $t_{SU-DATA}$  before SCLK toggles from low-to-high (see **Serial Interface Timing Characteristics**).

## 5.1.6 ACKNOWLEDGE (ACK)

Each receiving device, when addressed, is obliged to generate an ACK bit after the reception of each byte. The master device must generate an extra clock pulse for ACK to be recognized.

The acknowledging device pulls down the SDA line for  $t_{SU-DATA}$  before the low-to-high transition of SCLK from the master. SDA also needs to remain pulled down for  $t_{H-DATA}$  after a high-to-low transition of SCLK.

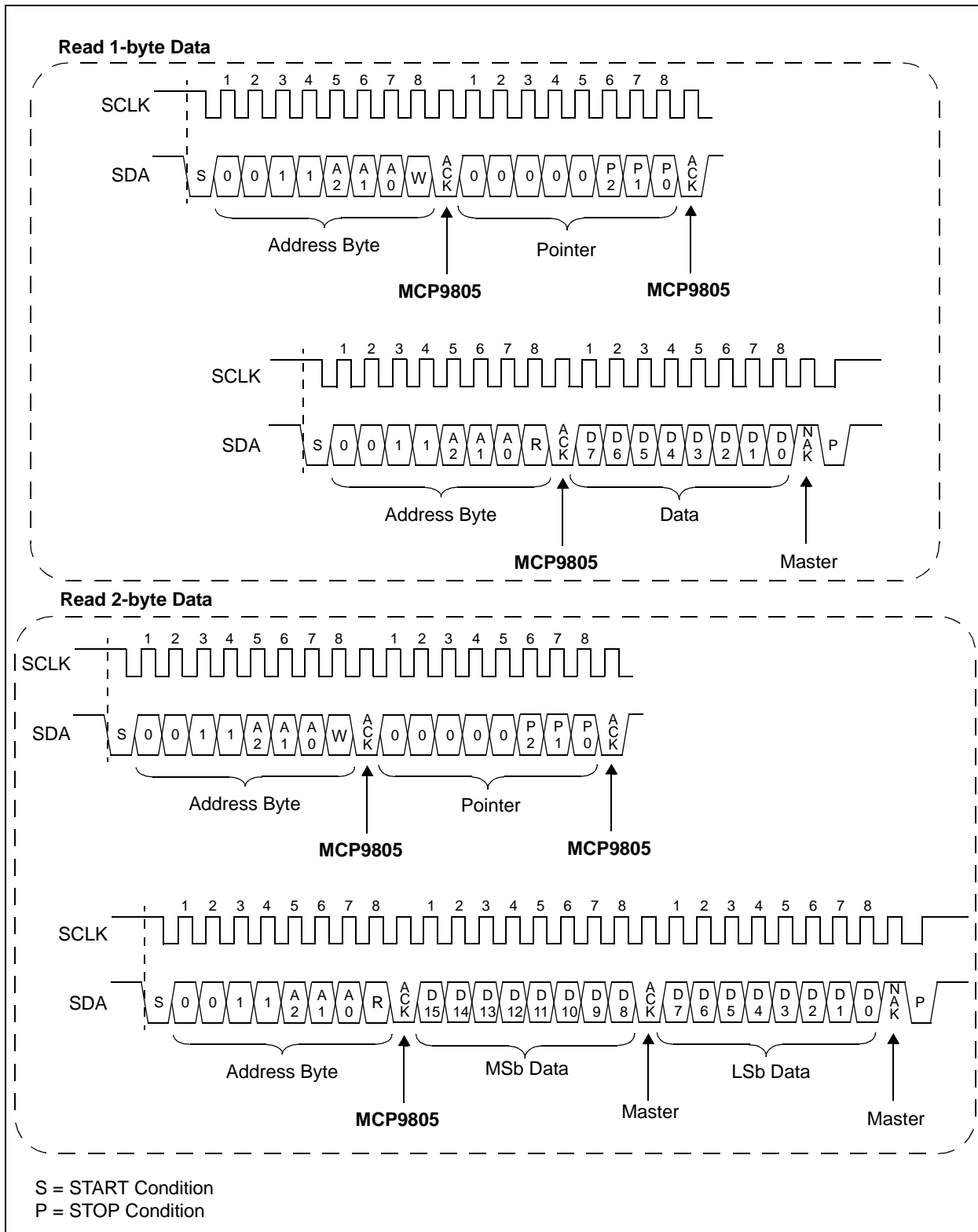
During read, the master must signal an End-of-Data (EOD) to the slave by not generating an ACK bit (NAK) once the last bit has been clocked out of the slave. In this case, the slave will leave the data line released to enable the master to generate the Stop condition.

## 5.1.7 TIME OUT

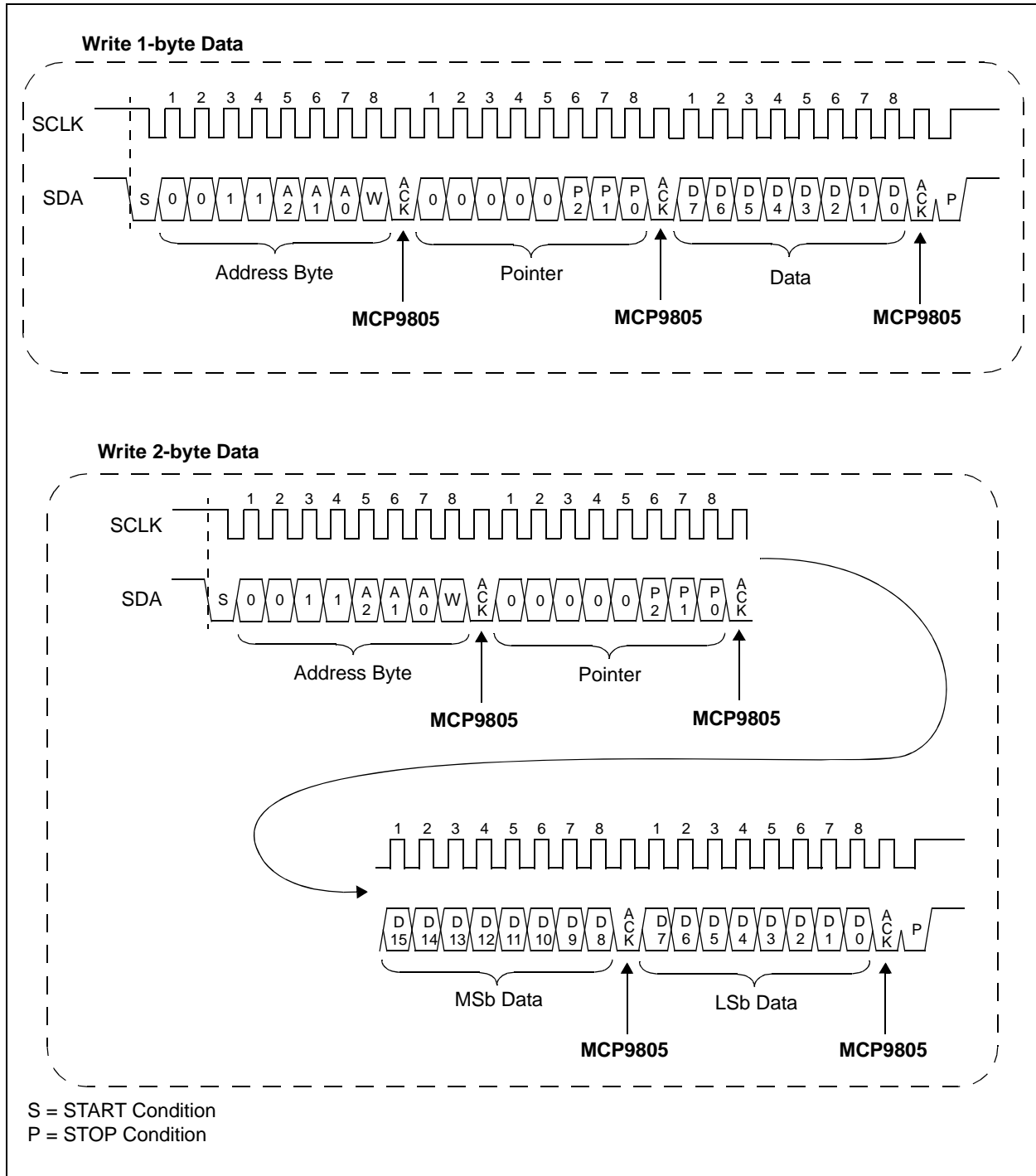
If the SCLK stays high or low for a time specified by  $t_{OUT}$ , the MCP9805 releases the bus and resets the serial interface. The master will have to restart the communication cycle with a Start condition. This dictates the minimum clock speed.

# MCP9805

## 5.2 Timing Diagram

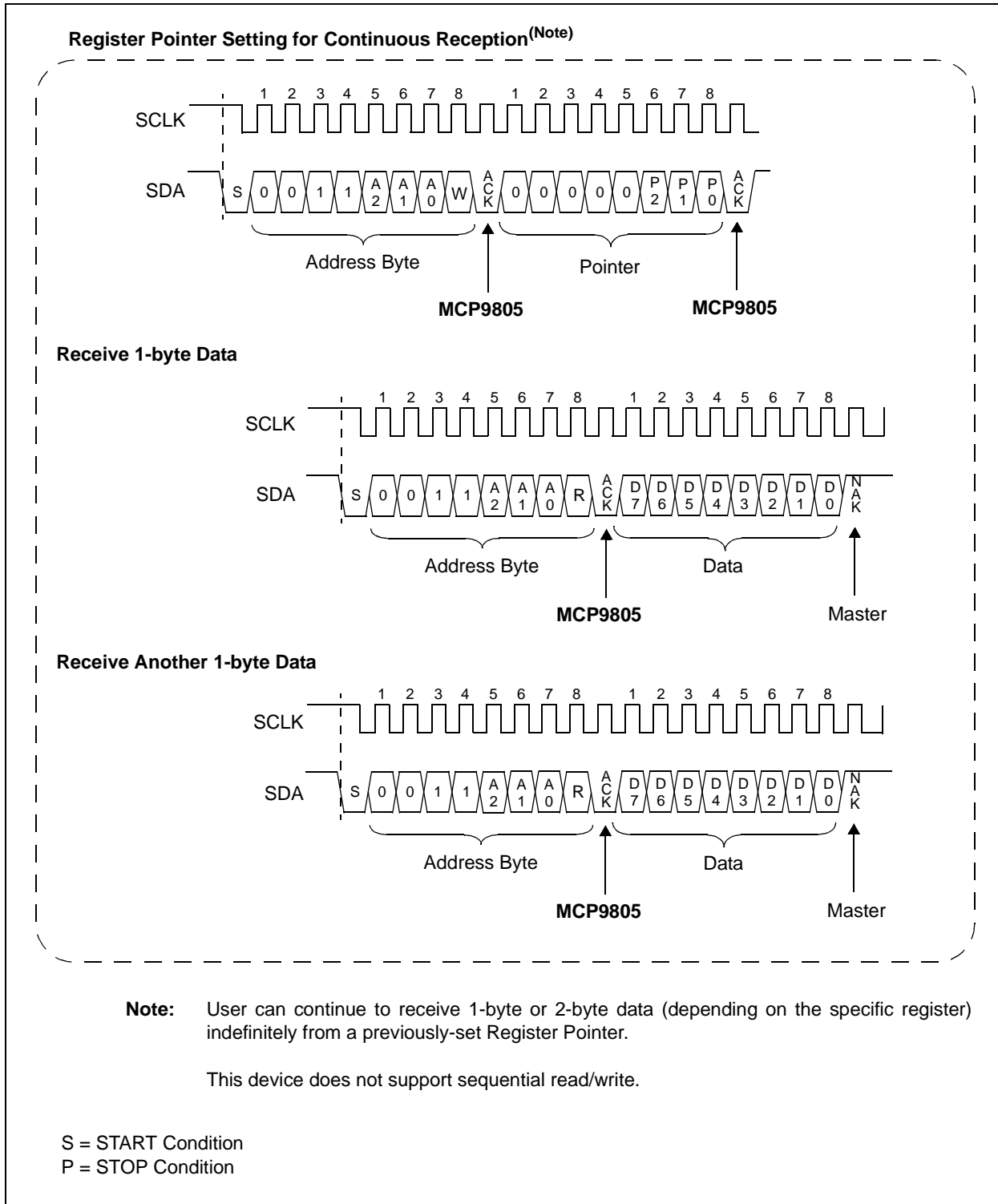


**FIGURE 5-2:** Read 1-byte and 2-byte data from a Register.



**FIGURE 5-3:** Write 1-byte and 2-byte data from a Register.

# MCP9805



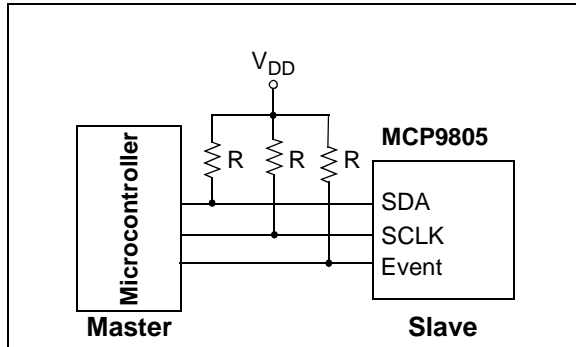
**FIGURE 5-4:** Receive 1-byte Data from Previously Set Pointer.



## 6.0 APPLICATIONS INFORMATION

### 6.1 Connecting to the Serial Bus

The SDA and SCLK serial interface pins are open-drain pins that require pull-up resistors. This configuration is shown in Figure 6-1.

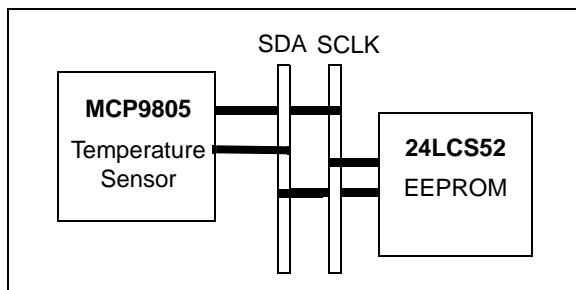


**FIGURE 6-1:** Pull-up Resistors On Serial Interface.

The number of devices connected to the bus is limited only by the maximum rise and fall times of the SDA and SCLK lines. Unlike I<sup>2</sup>C specifications, SMBus does not specify a maximum bus capacitance value. Rather, the SMBus specification requires that the maximum current through the pull-up resistor be 350  $\mu$ A and minimum 100  $\mu$ A. Because of this, the value of the pull-up resistors will vary depending on the system's bias voltage ( $V_{DD}$ ). The pull-up resistor values for a 3.3 V system ranges 9 k $\Omega$  to 33 k $\Omega$ . Minimizing bus capacitance is still very important as it directly affects the rise and fall times of the SDA and SCLK lines.

Although SMBus specifications only require the SDA and SCLK lines to pull-down 350  $\mu$ A, with a maximum voltage drop of 0.4 V, the MCP9805 is designed to meet a maximum voltage drop of 0.4 V, with 3 mA of current. This allows lower pull-up resistor values to be used, allowing the MCP9805 to handle higher bus capacitance. In such applications, all devices on the bus must meet the same pull-down current requirements.

A possible configuration using multiple devices on the SMBus is shown in Figure 6-2.



**FIGURE 6-2:** Multiple Devices on DIMM SMBus.

### 6.2 Layout Considerations

The MCP9805 does not require any additional components besides the master controller in order to measure temperature. However, it is recommended that a decoupling capacitor of 0.1  $\mu$ F to 1  $\mu$ F be used between the  $V_{DD}$  and GND pins. A high-frequency ceramic capacitor is recommended. It is necessary for the capacitor to be located as close as possible to the power and ground pins of the device in order to provide effective noise protection.

### 6.3 Thermal Considerations

A potential for self-heating errors can exist if the MCP9805 SDA, SCLK and Event lines are heavily loaded with pull-ups (high current). Typically, the self-heating error is negligible because of the relatively small current consumption of the MCP9805. A temperature accuracy error of approximately 0.5°C could result from self-heating if the communication pins sink/source the maximum current specified.

For example, if the Event output is loaded to maximum  $I_{OL}$ , Equation 6-1 can be used to determine the effect of self-heating.

#### EQUATION 6-1: EFFECT OF SELF-HEATING

$$T_{\Delta} = \theta_{JA}(V_{DD} \cdot I_{DD} + V_{OL\_Event} \cdot I_{OL\_Event} + V_{OL\_SDA} \cdot I_{OL\_SDA})$$

Where:

$$T_{\Delta} = T_J - T_A$$

$T_J$  = Junction Temperature

$T_A$  = Ambient Temperature

$\theta_{JA}$  = Package Thermal Resistance

$V_{OL\_Event, SDA}$  = Event and SDA Output  $V_{OL}$   
(0.4  $V_{max}$ )

$I_{OL\_Event, SDA}$  = Event and SDA Output  $I_{OL}$   
(3  $mA_{max}$ )

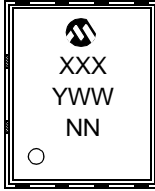
At room temperature ( $T_A = +25^{\circ}\text{C}$ ) with maximum  $I_{DD} = 500 \mu\text{A}$  and  $V_{DD} = 3.6\text{V}$ , the self-heating due to power dissipation  $T_{\Delta}$  is 0.2°C for the DFN-8 package and 0.5°C for the TSSOP-8 package.

# MCP9805

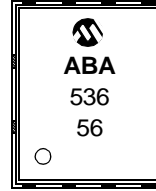
## 7.0 PACKAGING INFORMATION

### 7.1 Package Marking Information

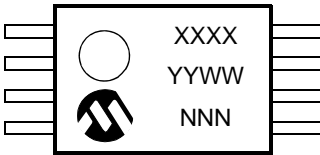
8-Lead DFN (MC)



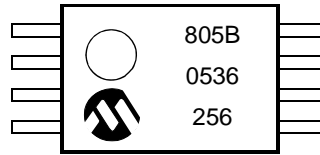
Example:



8-Lead TSSOP (ST)



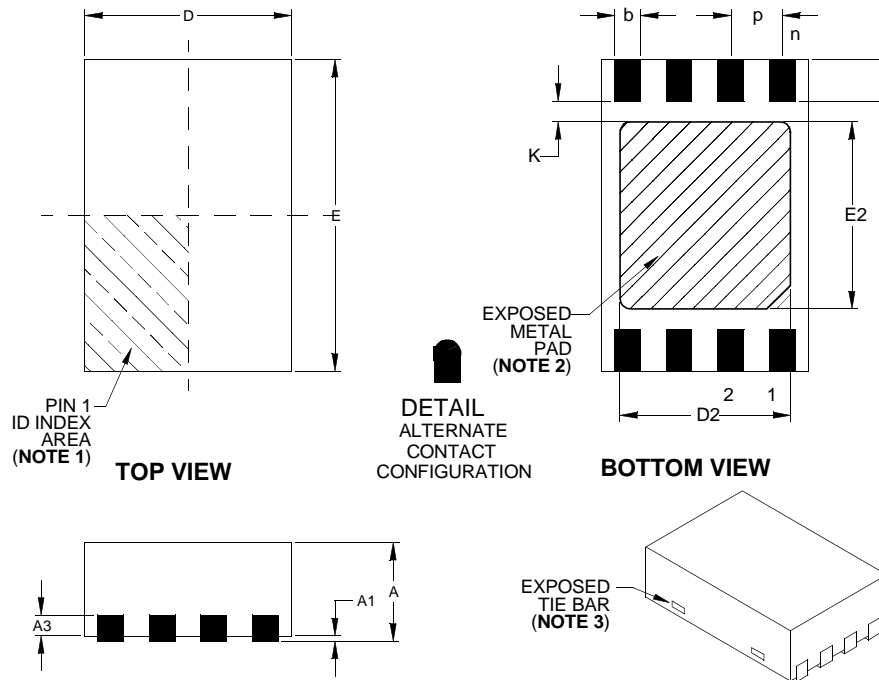
Example:



<b>Legend:</b>	XX...X	Customer-specific information
	Y	Year code (last digit of calendar year)
	YY	Year code (last 2 digits of calendar year)
	WW	Week code (week of January 1 is week '01')
	NNN	Alphanumeric traceability code
	(e3)	Pb-free JEDEC designator for Matte Tin (Sn)
	*	This package is Pb-free. The Pb-free JEDEC designator (e3) can be found on the outer packaging for this package.

**Note:** In the event the full Microchip part number cannot be marked on one line, it will be carried over to the next line, thus limiting the number of available characters for customer-specific information.

## 8-Lead Plastic Dual Flat No-Lead Package (MC) 2x3x0.9 mm Body (DFN) – Saw Singulated



Dimension Limits	Units	INCHES			MILLIMETERS*		
		MIN	NOM	MAX	MIN	NOM	MAX
Number of Pins	n		8			8	
Pitch	e	.020 BSC			0.50 BSC		
Overall Height	A	.031	.035	.039	0.80	0.90	1.00
Standoff	A1	.000	.001	.002	0.00	0.02	0.05
Contact Thickness	A3	.008 REF.			0.20 REF.		
Overall Length	D	.079 BSC			2.00 BSC		
Overall Width	E	.118 BSC			3.00 BSC		
Exposed Pad Length	D2	.051	–	.069	1.30**	–	1.75
Exposed Pad Width	E2	.059	–	.075	1.50**	–	1.90
Contact Length §	L	.012	.016	.020	0.30	0.40	0.50
Contact-to-Exposed Pad §	K	.008	–	–	0.20	–	–
Contact Width	b	.008	.010	.012	0.20	0.25	0.30

\* Controlling Parameter

\*\* Not within JEDEC parameters

§ Significant Characteristic

**Notes:**

1. Pin 1 visual index feature may vary, but must be located within the hatched area.

2. Exposed pad may vary according to die attach paddle size.

3. Package may have one or more exposed tie bars at ends.

BSC: Basic Dimension. Theoretically exact value shown without tolerances.

See ASME Y14.5M

REF: Reference Dimension, usually without tolerance, for information purposes only.

See ASME Y14.5M

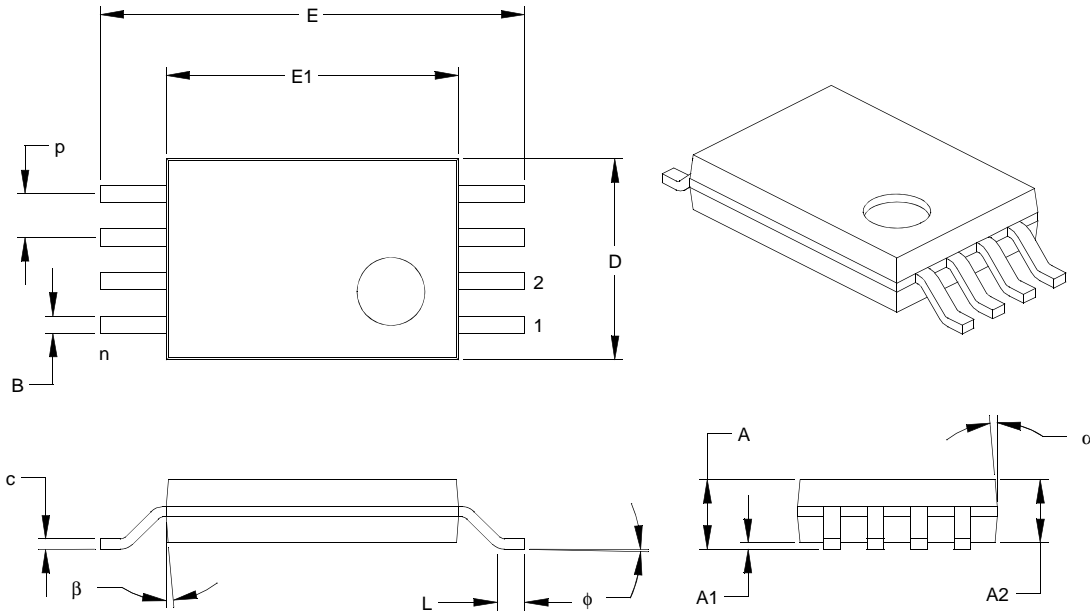
JEDEC Equivalent MO-229 VCED-2

DWG No. C04-123

Revised 09-12-05

# MCP9805

## 8-Lead Plastic Thin Shrink Small Outline (ST) – 4.4 mm Body (TSSOP)



Units		INCHES			MILLIMETERS*		
Dimension Limits		MIN	NOM	MAX	MIN	NOM	MAX
Number of Pins	n		8			8	
Pitch	p		.026			0.65	
Overall Height	A	.039	.041	.043	1.00	1.05	1.10
Molded Package Thickness	A2	.033	.035	.037	0.85	0.90	0.95
Standoff	A1	.002	.004	.006	0.05	0.10	0.15
Overall Width	E	.246	.251	.256	6.25	6.38	6.50
Molded Package Width	E1	.169	.173	.177	4.30	4.40	4.50
Molded Package Length	D	.114	.118	.122	2.90	3.00	3.10
Foot Length	L	.020	.024	.028	0.50	0.60	0.70
Foot Angle	phi	0°	4°	8°	0°	4°	8°
Lead Thickness	c	.004	.006	.008	0.09	0.15	0.20
Lead Width	B	.007	.010	.012	0.19	0.25	0.30
Mold Draft Angle Top	alpha	0°	5°	10°	0°	5°	10°
Mold Draft Angle Bottom	beta	0°	5°	10°	0°	5°	10°

\* Controlling Parameter

**Notes:**

Dimensions D and E1 do not include mold flash or protrusions. Mold flash or protrusions shall not exceed .005" (0.127mm) per side.

JEDEC Equivalent: MO-153

Drawing No. C04-086

Revised 07-21-05

## APPENDIX A: REVISION HISTORY

### Revision B (September 2005)

- Added the text “for Mobile Platform Memory Module Thermal Sensor” to first bullet under Features section.

### Revision A (September 2005)

- Original Release of this Document.

# MCP9805

---

NOTES:

## PRODUCT IDENTIFICATION SYSTEM

To order or obtain information, e.g., on pricing or delivery, refer to the factory or the listed sales office.

<u>PART NO.</u>	<u>-X</u>	<u>X</u>	<u>XX</u>
Device	Grade	Temperature Range	Package
Device: MCP9805: Digital Temperature Sensor MCP9805T: Digital Temperature Sensor (Tape and Reel)	B = $\pm 1^{\circ}\text{C}$ (max.) from $+75^{\circ}\text{C}$ to $+95^{\circ}\text{C}$ , $\pm 2^{\circ}\text{C}$ (max.) from $+40^{\circ}\text{C}$ to $+125^{\circ}\text{C}$ , and $\pm 3^{\circ}\text{C}$ (max.) from $-20^{\circ}\text{C}$ to $+125^{\circ}\text{C}$	E = $-40^{\circ}\text{C}$ to $+125^{\circ}\text{C}$	MC = Dual Flat No Lead (2x3 mm Body), 8-lead ST = Plastic Thin Shrink Small Outline (4x4 mm Body), 8-lead
<b>Examples:</b> a) MCP9805T-BE/MC: Tape and Reel, Extended Temp., 8LD DFN pkg. b) MCP9805-BE/ST: Extended Temp., 8LD TSSOP pkg. c) MCP9805T-BE/ST: Tape and Reel, Extended Temp., 8LD TSSOP pkg.			

# MCP9805

---

NOTES:



---

---

**Note the following details of the code protection feature on Microchip devices:**

- Microchip products meet the specification contained in their particular Microchip Data Sheet.
- Microchip believes that its family of products is one of the most secure families of its kind on the market today, when used in the intended manner and under normal conditions.
- There are dishonest and possibly illegal methods used to breach the code protection feature. All of these methods, to our knowledge, require using the Microchip products in a manner outside the operating specifications contained in Microchip's Data Sheets. Most likely, the person doing so is engaged in theft of intellectual property.
- Microchip is willing to work with the customer who is concerned about the integrity of their code.
- Neither Microchip nor any other semiconductor manufacturer can guarantee the security of their code. Code protection does not mean that we are guaranteeing the product as "unbreakable."

Code protection is constantly evolving. We at Microchip are committed to continuously improving the code protection features of our products. Attempts to break Microchip's code protection feature may be a violation of the Digital Millennium Copyright Act. If such acts allow unauthorized access to your software or other copyrighted work, you may have a right to sue for relief under that Act.

---

Information contained in this publication regarding device applications and the like is provided only for your convenience and may be superseded by updates. It is your responsibility to ensure that your application meets with your specifications. MICROCHIP MAKES NO REPRESENTATIONS OR WARRANTIES OF ANY KIND WHETHER EXPRESS OR IMPLIED, WRITTEN OR ORAL, STATUTORY OR OTHERWISE, RELATED TO THE INFORMATION, INCLUDING BUT NOT LIMITED TO ITS CONDITION, QUALITY, PERFORMANCE, MERCHANTABILITY OR FITNESS FOR PURPOSE. Microchip disclaims all liability arising from this information and its use. Use of Microchip's products as critical components in life support systems is not authorized except with express written approval by Microchip. No licenses are conveyed, implicitly or otherwise, under any Microchip intellectual property rights.

**Trademarks**

The Microchip name and logo, the Microchip logo, Accuron, dsPIC, KEELoQ, microID, MPLAB, PIC, PICmicro, PICSTART, PRO MATE, PowerSmart, rPIC, and SmartShunt are registered trademarks of Microchip Technology Incorporated in the U.S.A. and other countries.

AmpLab, FilterLab, Migratable Memory, MXDEV, MXLAB, PICMASTER, SEEVAL, SmartSensor and The Embedded Control Solutions Company are registered trademarks of Microchip Technology Incorporated in the U.S.A.

Analog-for-the-Digital Age, Application Maestro, dsPICDEM, dsPICDEM.net, dsPICworks, ECAN, ECONOMONITOR, FanSense, FlexROM, fuzzyLAB, In-Circuit Serial Programming, ICSP, ICEPIC, Linear Active Thermistor, MPASM, MPLIB, MPLINK, MPSIM, PCKIT, PICDEM, PICDEM.net, PICLAB, PICtail, PowerCal, PowerInfo, PowerMate, PowerTool, rLAB, rPICDEM, Select Mode, Smart Serial, SmartTel, Total Endurance and WiperLock are trademarks of Microchip Technology Incorporated in the U.S.A. and other countries.

SQTP is a service mark of Microchip Technology Incorporated in the U.S.A.

All other trademarks mentioned herein are property of their respective companies.

© 2005, Microchip Technology Incorporated, Printed in the U.S.A., All Rights Reserved.

 Printed on recycled paper.

**QUALITY MANAGEMENT SYSTEM**  
**CERTIFIED BY DNV**  
**== ISO/TS 16949:2002 ==**

*Microchip received ISO/TS-16949:2002 quality system certification for its worldwide headquarters, design and wafer fabrication facilities in Chandler and Tempe, Arizona and Mountain View, California in October 2003. The Company's quality system processes and procedures are for its PICmicro® 8-bit MCUs, KEELoQ® code hopping devices, Serial EEPROMs, microperipherals, nonvolatile memory and analog products. In addition, Microchip's quality system for the design and manufacture of development systems is ISO 9001:2000 certified.*



---

---

## WORLDWIDE SALES AND SERVICE

---

---

### AMERICAS

**Corporate Office**  
2355 West Chandler Blvd.  
Chandler, AZ 85224-6199  
Tel: 480-792-7200  
Fax: 480-792-7277  
Technical Support:  
<http://support.microchip.com>  
Web Address:  
[www.microchip.com](http://www.microchip.com)

**Atlanta**  
Alpharetta, GA  
Tel: 770-640-0034  
Fax: 770-640-0307

**Boston**  
Westborough, MA  
Tel: 774-760-0087  
Fax: 774-760-0088

**Chicago**  
Itasca, IL  
Tel: 630-285-0071  
Fax: 630-285-0075

**Dallas**  
Addison, TX  
Tel: 972-818-7423  
Fax: 972-818-2924

**Detroit**  
Farmington Hills, MI  
Tel: 248-538-2250  
Fax: 248-538-2260

**Kokomo**  
Kokomo, IN  
Tel: 765-864-8360  
Fax: 765-864-8387

**Los Angeles**  
Mission Viejo, CA  
Tel: 949-462-9523  
Fax: 949-462-9608

**San Jose**  
Mountain View, CA  
Tel: 650-215-1444  
Fax: 650-961-0286

**Toronto**  
Mississauga, Ontario,  
Canada  
Tel: 905-673-0699  
Fax: 905-673-6509

### ASIA/PACIFIC

**Australia - Sydney**  
Tel: 61-2-9868-6733  
Fax: 61-2-9868-6755

**China - Beijing**  
Tel: 86-10-8528-2100  
Fax: 86-10-8528-2104

**China - Chengdu**  
Tel: 86-28-8676-6200  
Fax: 86-28-8676-6599

**China - Fuzhou**  
Tel: 86-591-8750-3506  
Fax: 86-591-8750-3521

**China - Hong Kong SAR**  
Tel: 852-2401-1200  
Fax: 852-2401-3431

**China - Qingdao**  
Tel: 86-532-8502-7355  
Fax: 86-532-8502-7205

**China - Shanghai**  
Tel: 86-21-5407-5533  
Fax: 86-21-5407-5066

**China - Shenyang**  
Tel: 86-24-2334-2829  
Fax: 86-24-2334-2393

**China - Shenzhen**  
Tel: 86-755-8203-2660  
Fax: 86-755-8203-1760

**China - Shunde**  
Tel: 86-757-2839-5507  
Fax: 86-757-2839-5571

**China - Wuhan**  
Tel: 86-27-5980-5300  
Fax: 86-27-5980-5118

**China - Xian**  
Tel: 86-29-8833-7250  
Fax: 86-29-8833-7256

### ASIA/PACIFIC

**India - Bangalore**  
Tel: 91-80-2229-0061  
Fax: 91-80-2229-0062

**India - New Delhi**  
Tel: 91-11-5160-8631  
Fax: 91-11-5160-8632

**India - Pune**  
Tel: 91-20-2566-1512  
Fax: 91-20-2566-1513

**Japan - Yokohama**  
Tel: 81-45-471-6166  
Fax: 81-45-471-6122

**Korea - Gumi**  
Tel: 82-54-473-4301  
Fax: 82-54-473-4302

**Korea - Seoul**  
Tel: 82-2-554-7200  
Fax: 82-2-558-5932 or  
82-2-558-5934

**Malaysia - Penang**  
Tel: 604-646-8870  
Fax: 604-646-5086

**Philippines - Manila**  
Tel: 632-634-9065  
Fax: 632-634-9069

**Singapore**  
Tel: 65-6334-8870  
Fax: 65-6334-8850

**Taiwan - Hsin Chu**  
Tel: 886-3-572-9526  
Fax: 886-3-572-6459

**Taiwan - Kaohsiung**  
Tel: 886-7-536-4818  
Fax: 886-7-536-4803

**Taiwan - Taipei**  
Tel: 886-2-2500-6610  
Fax: 886-2-2508-0102

**Thailand - Bangkok**  
Tel: 66-2-694-1351  
Fax: 66-2-694-1350

### EUROPE

**Austria - Weis**  
Tel: 43-7242-2244-399  
Fax: 43-7242-2244-393

**Denmark - Copenhagen**  
Tel: 45-4450-2828  
Fax: 45-4485-2829

**France - Paris**  
Tel: 33-1-69-53-63-20  
Fax: 33-1-69-30-90-79

**Germany - Munich**  
Tel: 49-89-627-144-0  
Fax: 49-89-627-144-44

**Italy - Milan**  
Tel: 39-0331-742611  
Fax: 39-0331-466781

**Netherlands - Drunen**  
Tel: 31-416-690399  
Fax: 31-416-690340

**Spain - Madrid**  
Tel: 34-91-352-30-52  
Fax: 34-91-352-11-47

**UK - Wokingham**  
Tel: 44-118-921-5869  
Fax: 44-118-921-5820



08/24/05

# Mouser Electronics

Authorized Distributor

Click to View Pricing, Inventory, Delivery & Lifecycle Information:

[Microchip:](#)

[MCP9805-BE/ST](#) [MCP9805T-BE/MC](#) [MCP9805T-BE/ST](#)