

# NB3F8L3005C

## 3.3V / 2.5V / 1.8V / 1.5V 2:1:5 LVC MOS Fanout Buffer

### Description

The NB3F8L3005C is a 2:1:5 Clock / Data fanout buffer operating on a 3.3 V / 2.5 V Core  $V_{DD}$  and two flexible 3.3 V / 2.5 V / 1.8 V / 1.5 V  $V_{DDO_x}$  supplies which must be equal or less than  $V_{DD}$ .

A Mux selects between a Crystal input, or a differential/SE Clock / Data inputs. Differential Inputs accept LVPECL, LVDS, HCSL, or SSTL and Single-Ended levels. The MUX control line, SEL selects CLK/ $\overline{\text{CLK}}$ , or Crystal input pins per Table 3. The Crystal input is disabled when a Clock input is selected. Output enable pin, OE, synchronously forces a High Impedance state (Hi-Z) when Low per Table 4.

Outputs consist of five single-ended LVC MOS outputs.

### Features

- Five LVC MOS / LV TTL Outputs up to 200 MHz
- Differential Inputs Accept LVPECL, LVDS, HCSL, SSTL, or LVC MOS/LV TTL
- Crystal Interface
- Crystal Input Frequency Range: 10 MHz to 50 MHz
- Output Skew: 10 ps Typical
- Additive RMS Phase Jitter @ 156.25 MHz, (12 kHz – 20 MHz): 0.03 ps (Typical)
- Synchronous Output Enable
- Output Defined Level When Input is Floating
- Power Supply Modes:
  - ◆ Single 3.3 V  $\pm$  5%
  - ◆ Single 2.5 V  $\pm$  5%
  - ◆ Mixed 3.3 V  $\pm$  5% Core/2.5 V  $\pm$  5% Output Operating Supply
  - ◆ Mixed 3.3 V  $\pm$  5% Core/1.8 V  $\pm$  0.2 V Output Operating Supply
  - ◆ Mixed 3.3 V  $\pm$  5% Core/1.5 V  $\pm$  0.15 V Output Operating Supply
  - ◆ Mixed 2.5 V  $\pm$  5% Core/ 1.8 V  $\pm$  0.2 V Output Operating Supply
  - ◆ Mixed 2.5 V  $\pm$  5% Core /1.5 V  $\pm$  0.15 V Output Operating Supply
- Two Separate Output Bank Power Supplies
- Industrial Temperature Range:  $-40^{\circ}\text{C}$  to  $85^{\circ}\text{C}$
- These are Pb-Free Devices

### Applications

- Clock Distribution
- Networking and Communications
- High End Computing
- Wireless and Wired Infrastructure

### End Products

- Servers
- Ethernet Switch/Routers
- ATE
- Test and Measurement



ON Semiconductor®

[www.onsemi.com](http://www.onsemi.com)

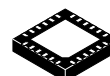

QFN24  
G SUFFIX  
CASE 485DJ

### MARKING DIAGRAM

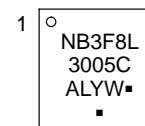

A = Assembly Location  
L = Wafer Lot  
Y = Year  
W = Work Week  
■ = Pb-Free Package

(Note: Microdot may be in either location)

### ORDERING INFORMATION

See detailed ordering and shipping information on page 12 of this data sheet.

# NB3F8L3005C

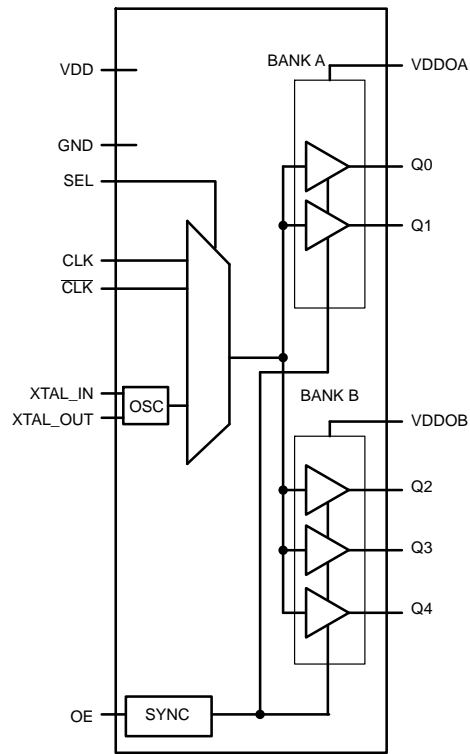

**Figure 1. Simplified Logic Diagram**

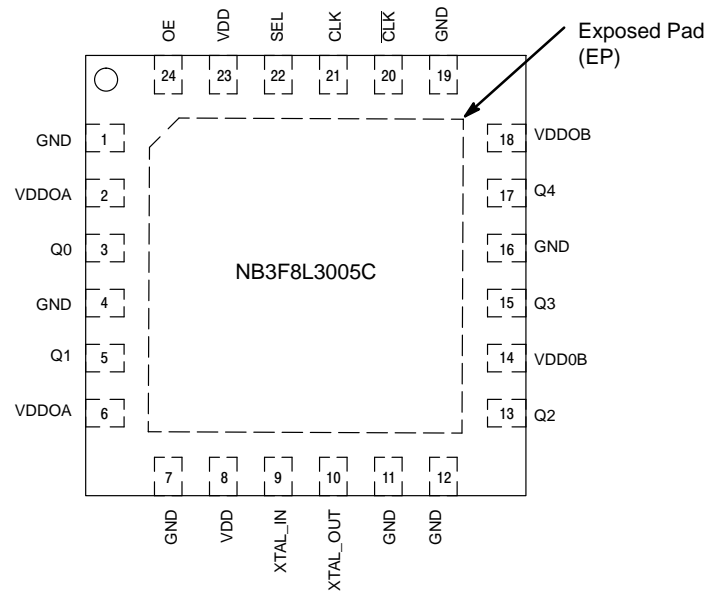

**Figure 2. Pinout Configuration (Top View)**

# NB3F8L3005C

**Table 1. PIN DESCRIPTION**

Number	Name	Type	Input Default	Description
3, 5	Q0, Q1	LVC MOS		Outputs – Bank A
13, 15, 17	Q2, Q3, Q4	LVC MOS		Outputs – Bank B
2, 6	VDDOA	Power		Positive Supply Pins for Bank A Outputs Q0 – Q1
14, 18	VDDOB	Power		Positive Supply Pins for Bank B Outputs Q2 – Q4
1, 4, 7, 11, 12, 16, 19	GND	GND		Ground Supply
8, 23	VDD	Power		V <sub>DD</sub> Positive Supply pin for Core and Inputs.
9	XTAL_IN	XTAL OSC / CLK Input		Crystal Oscillator Interface or External Clock Source at LVC MOS Levels
10	XTAL_OUT	XTAL OSC Output		Crystal Interface
20	CLK	Diff / SE Input	Pullup / Pulldown	Inverting differential clock input
21	CLK	Diff / SE Input	Pulldown	Non-inverting clock input
22	SEL	LVC MOS / LV TTL Input	Pulldown	Input clock select. See Table 3 for function. Input Pulldown
24	OE	LVC MOS / LV TTL Input	Pulldown	Output Enable Control. See Table 4 for function.
–	EP	–		The Exposed Pad (EP) on the QFN–24 package bottom is thermally connected to the die for improved heat transfer out of package. The exposed pad must be attached to a heat-sinking conduit. The pad is electrically connected to the die, and must be electrically connected to GND.

- All VDD, VDDO<sub>x</sub> and GND pins must be externally connected to a power supply to guarantee proper operation. Bypass each V<sub>DD</sub> and VDDO<sub>x</sub> with 0.01 μF CAP to GND.

**Table 2. PIN CHARACTERISTICS**

Symbol	Parameter	Min	Typ	Max	Unit
C <sub>IN</sub>	Input Capacitance		4		pF
R <sub>PU</sub>	Input Pullup Resistor		50		kΩ
R <sub>PD</sub>	Input Pulldown Resistor		50		kΩ
C <sub>PD</sub>	Power Dissipation Capacitance (per output) VDDO = 3.3 V VDDO = 2.5 V VDDO = 1.8 V VDDO = 1.5 V				pF
R <sub>OUT</sub>	Output Impedance VDDO = 3.3 V VDDO = 2.5 V VDDO = 1.8 V VDDO = 1.5 V		20		Ω

# NB3F8L3005C

## FUNCTION TABLES

**Table 3. CLOCK ENABLE (SELx) FUNCTION TABLE**

SEL Input	Selected Input Clock
0	CLK/CLK
1	Crystal Osc Input

**Table 4. CLOCK OUTPUT ENABLE (OE) FUNCTION TABLE**

OE Input	Q <sub>n</sub> Outputs
0	Disabled, High Impedance
1	Outputs Enabled

**Table 5. CLK INPUT VS. OUTPUT STATUS**

Input Condition	Output
CLK/CLK = OPEN	Logic LOW
CLK/CLK = GND	Undefined
CLK = HIGH; CLK = LOW	Logic HIGH
CLK = LOW; CLK = HIGH	Logic LOW

**Table 6. CRYSTAL CHARACTERISTICS**

Parameter	Min	Typ	Max	Unit
Mode of Oscillation	Fundamental			
Frequency	10		50	MHz
Equivalent Series Resistance (ESR)			50	Ω
Shunt Capacitance			7	pF
Drive Power			100	μW

**Table 7. ATTRIBUTES**

Characteristic	Value
ESD Protection Human Body Model Machine Model	>2 kV 200 V
Moisture Sensitivity (Note 2) QFN24	Level 3
Flammability Rating Oxygen Index: 28 to 34	UL 94 V-0 @ 0.125 in
Transistor Count	474
Meets or exceeds JEDEC Spec EIA/JESD78 IC Latchup Test	

2. For additional information, see Application Note AND8003/D.

**Table 8. MAXIMUM RATINGS** (Note 3)

Symbol	Parameter	Condition	Rating	Unit	
V <sub>DD</sub> , VDDO <sub>x</sub>	Positive Power Supply	GND = 0 V	4.6	V	
V <sub>I</sub>	Input Voltage XTAL_IN Diff, SELx, OE Inputs		0 ≤ V <sub>I</sub> ≤ V <sub>DD</sub> -0.5 ≤ V <sub>I</sub> ≤ V <sub>DD</sub> + 0.5	V	
V <sub>O</sub>	Output Voltage		-0.5 ≤ V <sub>O</sub> ≤ VDDO <sub>x</sub> + 0.5	V	
T <sub>stg</sub>	Storage Temperature Range		-65 to +150	°C	
θ <sub>JA</sub>	Thermal Resistance (Junction-to-Ambient)	QFN24 QFN24	0 lfpm 500 lfpm	37 32	°C/W
θ <sub>JC</sub>	Thermal Resistance (Junction-to-Case)	QFN24	(Note 3)	11	°C/W

Stresses exceeding those listed in the Maximum Ratings table may damage the device. If any of these limits are exceeded, device functionality should not be assumed, damage may occur and reliability may be affected.

3. JEDEC standard multilayer board – 2S2P (2 signal, 2 power).

## NB3F8L3005C

**Table 9. POWER SUPPLY CHARACTERISTICS**  $V_{DD} \geq V_{DDO}$ ;  $V_{DD} = 3.3 \text{ V} \pm 5\%$  (3.135 V to 3.465 V) or  $V_{DD} = 2.5 \text{ V} \pm 5\%$  (2.375 V to 2.625 V) and  $V_{DDOx} = 3.3 \text{ V} \pm 5\%$  (3.135 V to 3.465 V) or  $2.5 \text{ V} \pm 5\%$  (2.375 V to 2.625 V) or  $1.8 \text{ V} \pm 0.2 \text{ V}$  (1.6 V to 2.0 V) or  $1.5 \text{ V} \pm 0.15 \text{ V}$  (1.35 V to 1.65 V);  $T_A = -40^\circ\text{C}$  to  $85^\circ\text{C}$

Symbol	Parameter	Test Conditions	Min	Typ	Max	Unit
$I_{DD}$	$V_{DD}$ Power Supply Current	$f_{IN} = 0 \text{ MHz}$ $V_{DDO} = 3.3 \text{ V}, f_{IN} = 100 \text{ MHz}$ $V_{DDO} = 2.5 \text{ V}, f_{IN} = 100 \text{ MHz}$		30 30 20	38	mA
$I_{DDO}$	$V_{DDO}$ Power Supply Current	OE = 0, no load $V_{DDO} = 3.3 \text{ V}, OE = 1, f_{IN} = 100 \text{ MHz}$ $V_{DDO} = 2.5 \text{ V}, OE = 1, f_{IN} = 100 \text{ MHz}$		0.1 7 5		mA
$I_{DD} + I_{DDO}$	Total Device Current with Loads on All Outputs	OE = 1, $f_{IN} = 100 \text{ MHz}$ OE = 0		48 16		mA

NOTE: Device will meet the specifications after thermal equilibrium has been established when mounted in a test socket or printed circuit board with maintained transverse airflow greater than 500 lpm.

**Table 10. DC CHARACTERISTICS**  $T_A = -40^\circ\text{C}$  to  $85^\circ\text{C}$

Symbol	Parameter	Test Conditions	Min	Typ	Max	Unit
$V_{IH}$	LVC MOS / LV TTL Input High Voltage (OE, SEL)	$V_{DD} = 3.3 \text{ V} \pm 5\%$ $V_{DD} = 2.5 \text{ V} \pm 5\%$	1.6 1.3		$V_{DD} + 0.3$ $V_{DD} + 0.3$	V
$V_{IL}$	LVC MOS / LV TTL Input Low Voltage (OE, SEL)	$V_{DD} = 3.3 \text{ V} \pm 5\%$ $V_{DD} = 2.5 \text{ V} \pm 5\%$	-0.3 -0.3		0.8 0.4	V
$I_{IH}$	Input High Current OE, SEL CLK/CLK	$V_{DD} = V_{IN} = 3.465 \text{ V}$ $V_{DD} = V_{IN} = 3.465 \text{ V}$ or $2.625 \text{ V}$			100 100	$\mu\text{A}$
$I_{IL}$	Input Low Current OE, SEL CLK CLK	$V_{DD} = 3.465 \text{ V}; V_{IN} = 0.0 \text{ V}$ $V_{DD} = 3.465 \text{ V}$ or $2.625 \text{ V}; V_{IN} = 0.0 \text{ V}$ $V_{DD} = 3.465 \text{ V}$ or $2.625 \text{ V}; V_{IN} = 0.0 \text{ V}$	-5 -5 -150		5	$\mu\text{A}$
$V_{OH}$	Output High Voltage		$V_{DDO}$ -0.1			V
$V_{OL}$	Output Low Voltage	$V_{DDOx} = 3.3 \text{ V} \pm 5\%$ or $2.5 \text{ V} \pm 5\%$			0.5	V
		$V_{DDOx} = 1.8 \text{ V} \pm 0.2 \text{ V}$			0.4	
		$V_{DDOx} = 1.5 \text{ V} \pm 0.15 \text{ V}$			0.37	
$V_{PP}$	Peak-to-Peak Input Voltage $V_{IL} > -0.3 \text{ V}$ CLKx/CLKx	$V_{DD} = 3.3 \text{ V} \pm 5\%$ or $V_{DD} = 2.5 \text{ V} \pm 5\%$	0.15		1.3	V
$V_{IHCMR}$	Input High Level Common Mode Range $V_{CM} = V_{IH}; V_{IL} > -0.3 \text{ V}$ CLKx/CLKx	$V_{DD} = 3.3 \text{ V} \pm 5\%$ or $V_{DD} = 2.5 \text{ V} \pm 5\%$	0.5		$V_{DD} - 0.85$	V

NOTE: Device will meet the specifications after thermal equilibrium has been established when mounted in a test socket or printed circuit board with maintained transverse airflow greater than 500 lpm.

## NB3F8L3005C

**Table 11. AC CHARACTERISTICS**  $V_{DD} \geq V_{DDO}$ ;  $V_{DD} = 3.3 \text{ V} \pm 5\%$  (3.135 V to 3.465 V) or  $V_{DD} = 2.5 \text{ V} \pm 5\%$  (2.375 V to 2.625 V) and  $V_{DDOx} = 3.3 \text{ V} \pm 5\%$  (3.135 V to 3.465 V) or  $2.5 \text{ V} \pm 5\%$  (2.375 V to 2.625 V) or  $1.8 \text{ V} \pm 0.2 \text{ V}$  (1.6 V to 2.0 V) or  $1.5 \text{ V} \pm 0.15 \text{ V}$  (1.35 V to 1.65 V);  $T_A = -40^\circ\text{C}$  to  $85^\circ\text{C}$

Symbol	Parameter		Test Conditions	Min	Typ	Max	Unit
$f_{MAX}$	Output Frequency	Using External Crystal		10		50	MHz
		Using External Clock Source (Note 4)		DC		200	MHz
$t_{sk(o)}$	Output Skew (Notes 5 and 6)				10	25	ps
$t_{JITTER\Phi}$	Additive RMS Phase Jitter (Integrated 12 kHz – 20 MHz) $f_C = 156.25 \text{ MHz}$	Input clock from CLK/CLK	$V_{DDOx} = 3.3 \text{ V} \pm 5\%$		0.03		ps
			$V_{DDOx} = 2.5 \text{ V} \pm 5\%$		0.03		
			$V_{DDOx} = 1.8 \text{ V} \pm 0.2 \text{ V}$		0.03		
			$V_{DDOx} = 1.5 \text{ V} \pm 0.15 \text{ V}$		0.03		
		External clock over drives crystal interface	$V_{DDOx} = 3.3 \text{ V} \pm 5\%$		0.03		
			$V_{DDOx} = 2.5 \text{ V} \pm 5\%$		0.03		
			$V_{DDOx} = 1.8 \text{ V} \pm 0.2 \text{ V}$		0.03		
			$V_{DDOx} = 1.5 \text{ V} \pm 0.15 \text{ V}$		0.03		
		Input clock from crystal	$V_{DDOx} = 3.3 \text{ V} \pm 5\%$		0.03		
			$V_{DDOx} = 2.5 \text{ V} \pm 5\%$		0.03		
			$V_{DDOx} = 1.8 \text{ V} \pm 0.2 \text{ V}$		0.03		
			$V_{DDOx} = 1.5 \text{ V} \pm 0.15 \text{ V}$		0.03		
$t_R / t_F$	Output Rise/Fall Time (20% and 80%) $C_L = 10 \text{ pF}$		$V_{DDOx} = 3.3 \text{ V} \pm 5\%$	150	350	500	ps
			$V_{DDOx} = 2.5 \text{ V} \pm 5\%$	150	350	500	
			$V_{DDOx} = 1.8 \text{ V} \pm 0.2 \text{ V}$	150	350	600	
			$V_{DDOx} = 1.5 \text{ V} \pm 0.15 \text{ V}$	150	350	600	
odc	Output Duty Cycle		$V_{DDOx} = 3.3 \text{ V} \pm 5\%$	45		55	%
			$V_{DDOx} = 2.5 \text{ V} \pm 5\%$	40		60	
			$V_{DDOx} = 1.8 \text{ V} \pm 0.2 \text{ V}$	40		60	
			$V_{DDOx} = 1.5 \text{ V} \pm 0.15 \text{ V}$	40		60	
PSRR	Power Supply Ripple Rejection		100 kHz, 100 mV <sub>PP</sub> Ripple Injected on $V_{DD}$ , $V_{DDO} = 2.5 \text{ V}$		-44		dBc
$t_{EN}$	Output Enable Time (Note 7)	OE				4	cycles
$t_{DIS}$	Output Disable Time (Note 7)	OE				4	cycles
MUX_ISOLATION	MUX_ISOLATION		155.52 MHz	55			dB

NOTE: Device will meet the specifications after thermal equilibrium has been established when mounted in a test socket or printed circuit board with maintained transverse airflow greater than 500 lfm.

4. XTAL\_IN can be overdriven relative to a signal a crystal would provide.
5. Defined as skew between outputs at the same supply voltage and with equal load conditions. Measured at  $V_{DDOx}/2$ .
6. This parameter is defined in accordance with JEDEC Standard 65.
7. These parameters are guaranteed by characterization. Not tested in production. See Parameter Measurement Information
8. AC parameters for LVCMOS are dependent upon output capacitive loading.

PARAMETER MEASUREMENT INFORMATION

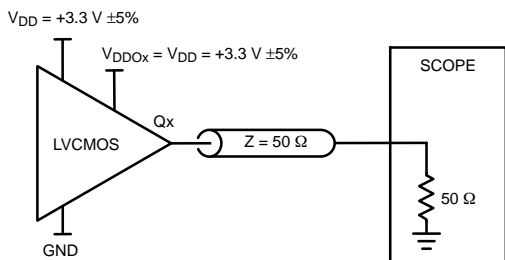

3.3 V Core / 3.3 V Output Load AC Test Circuit

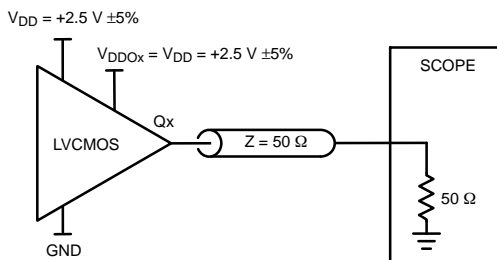

2.5 V Core / 2.5 V Output Load AC Test Circuit

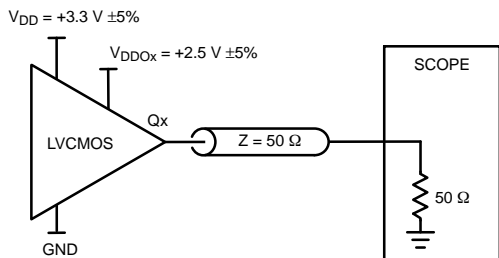

3.3 V Core / 2.5 V Output Load AC Test Circuit

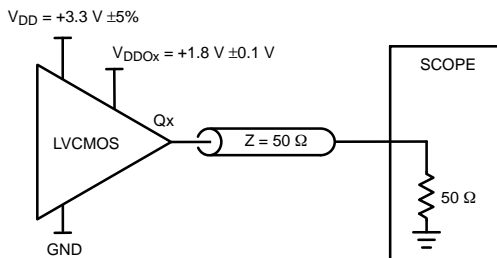

3.3 V Core / 1.8 V Output Load AC Test Circuit

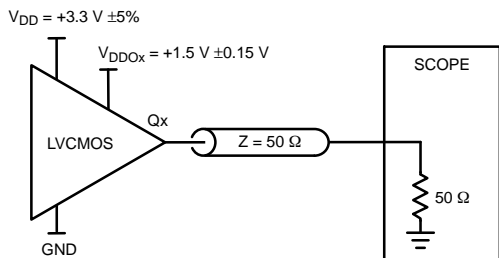

3.3 V Core / 1.5 V Output Load AC Test Circuit

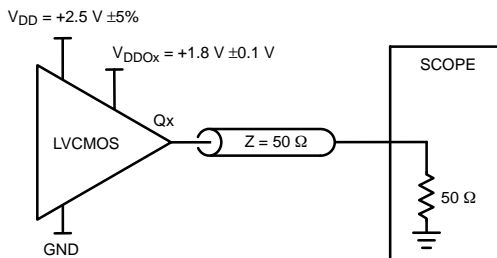

2.5 V Core / 1.8 V Output Load AC Test Circuit

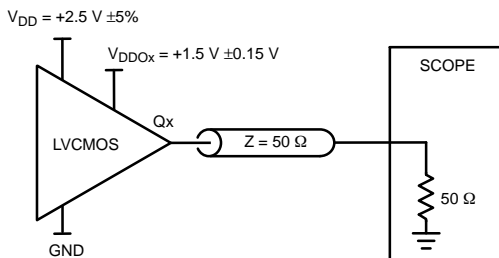

2.5 V Core / 1.5 V Output Load AC Test Circuit

Figure 3. Operational Supply and Termination Test Conditions

PARAMETER MEASUREMENT INFORMATION

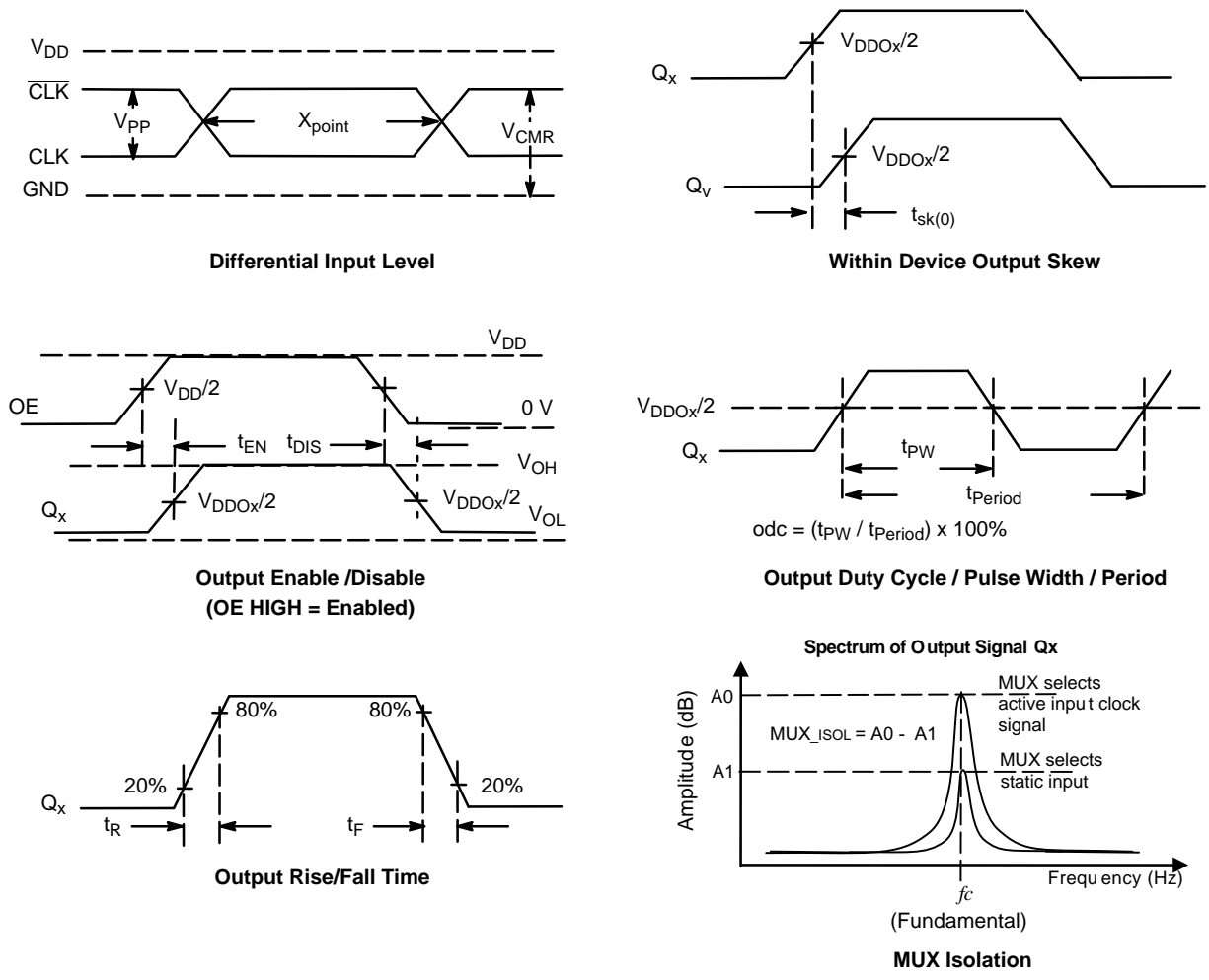

Figure 4. Operational Waveforms and MUX Input Isolation Plot

APPLICATION INFORMATION

Recommendations for Unused LVC MOS Output Pins

Inputs:

CLK/CLK Inputs

For applications not requiring the use of the differential input, both CLK and  $\overline{\text{CLK}}$  can be left floating. Though not required, but for additional protection, a 1 kΩ resistor can be tied from CLK to ground.

Crystal Inputs

For applications not requiring the use of the crystal oscillator input, both XTAL\_IN and XTAL\_OUT can be left floating. Though not required, but for additional protection, a 1 kΩ resistor can be tied from XTAL\_IN to ground.

LVC MOS Control Pins

All control pins have internal pulldowns; additional resistance is not required but can be added for additional protection. A 1 kΩ resistor can be used.

Power Supplies

VDD is the power supply for the core and input circuitry.

VDDOA and VDDOB are two separate positive power supplies for two banks of outputs:

VDDOA pins 2 and 6 are connected internally for outputs Q0 – Q1.

VDDOB pins 14 and 18 are connected internally for outputs Q2 – Q4.



**Differential Input with Single-Ended Interconnect**

Refer to Figure 5 to interconnect a single-ended to a Differential Pair of inputs. The reference bias voltage  $V_{REF} = V_{DD}/2$  is generated by the resistor divider of R3 and R4. Bypass capacitor (C1) can filter noise on the DC bias. This bias circuit should be located as close to the input pin as possible. Adjust R1 and R2 to common mode voltage of the signal input swing to preserve duty cycle.

This configuration requires that the sum of the output impedance of the driver ( $R_o$ ) and the series resistance ( $R_s$ ) equals the transmission line impedance. In addition, matched termination by R1 and R2 will attenuate the signal

amplitude in half. Termination may be done by using  $R_s$  or by using R1 and R2. First,  $R_s = 0$  and then R3 and R4 in parallel should equal the transmission line impedance. For most  $50\ \Omega$  applications, R1 and R2 can be  $100\ \Omega$ . The differential input can handle full rail LVCMOS signaling, but it is recommended that the amplitude be reduced. The datasheet specifies a differential amplitude which needs to be doubled for a single ended equivalent stimulus.  $V_{ILmin}$  cannot be less than  $-0.3\ V$  and  $V_{IHmax}$  cannot be more than  $V_{DD} + 0.3\ V$ . The datasheet specifications are characterized and guaranteed by using a differential signal.

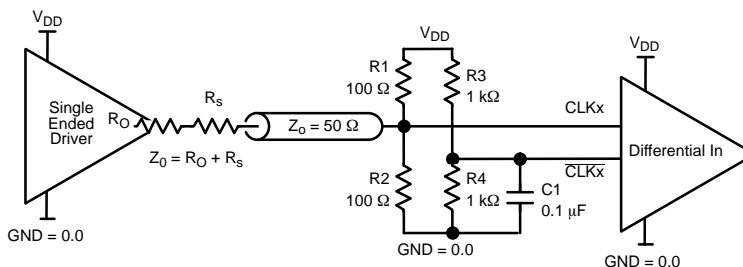

Figure 5. Differential Input with Single-ended Interconnect

**Crystal Input Interface**

The device has been characterized with  $18\ pF$  parallel resonant crystals. The capacitor values, C1 and C2, shown in Figure 6 below as  $15\ pF$  were determined using an  $18\ pF$  parallel resonant crystal and were chosen to minimize the ppm error. The optimum C1 and C2 values can be slightly adjusted for different board layouts.

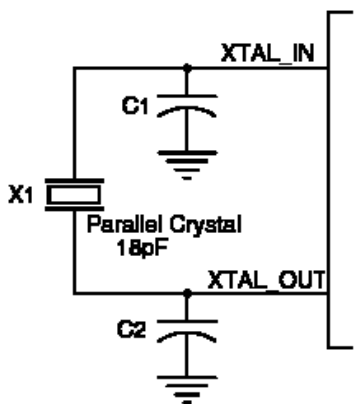

Figure 6. Crystal Input Interface

**CLOCK Overdriving the XTAL Interface**

The XTAL\_IN input can accept a single-ended LVCMOS signal through an AC coupling capacitor. A general LVCMOS interface diagram is shown in Figure 7 and a general LVPECL interface in Figure 8. The XTAL\_OUT pin must be left floating. The maximum amplitude of the input signal should not exceed  $2\ V$  and the input edge rate can be as slow as  $10\ ns$ . This configuration requires that the output impedance of the driver ( $R_o$ ) plus the series resistance ( $R_s$ ) equals the transmission line impedance. In addition, matched termination at the crystal input will attenuate the signal in half. This can be done in one of two ways. First, R1 and R2 in parallel should equal the transmission line impedance. For most  $50\ \Omega$  applications, R1 and R2 can be  $100\ \Omega$ . This can also be accomplished by removing R1 and making R2  $50\ \Omega$ . By overdriving the crystal oscillator, the device will be functional, but note, the device performance is guaranteed by using a quartz crystal.

# NB3F8L3005C

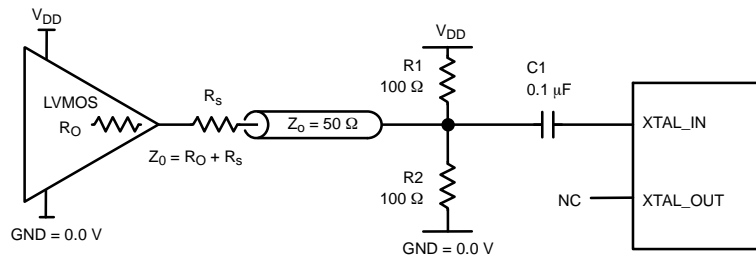

Figure 7. General Diagram for LVMOS Driver to XTAL Input Interface Use  $R_s$  or  $R_1 / R_2$

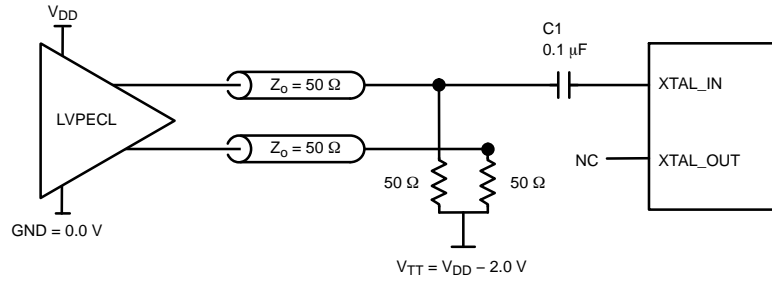
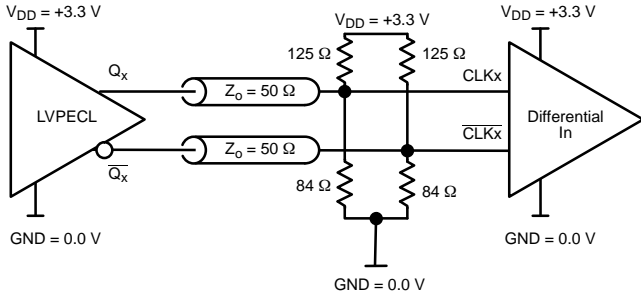

Figure 8. General Diagram for LVPECL Driver to XTAL Input Interface

**Differential Clock Input Interface**

The CLK /  $\overline{\text{CLK}}$  accept LVDS, LVPECL, SSTL, HCSL differential signals. Signals must meet the  $V_{PP}$  and  $V_{CMR}$  input requirements. Figures 9 to 13 show interface examples for the CLK /  $\overline{\text{CLK}}$  input with built-in 50  $\Omega$  terminations driven by the most common driver types. The

input interfaces suggested here are examples only. If the driver is from another vendor, use their termination recommendation. Please consult with the vendor of the driver component to confirm the driver termination requirements.



**Figure 9. CLK /  $\overline{\text{CLK}}$  Input Driven by 3.3 V LVPECL Driver (Thevenin Parallel Termination)**

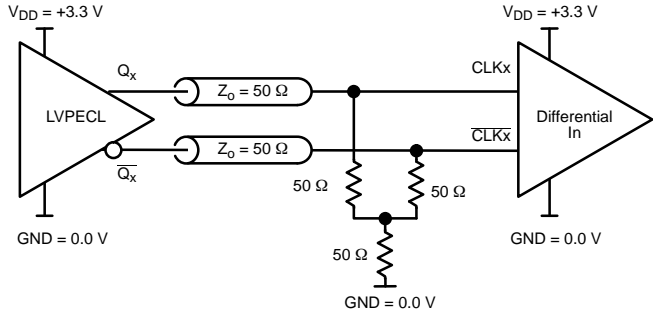

**Figure 10. CLK /  $\overline{\text{CLK}}$  Input Driven by 3.3 V LVPECL Driver ("Y" Parallel Termination)**

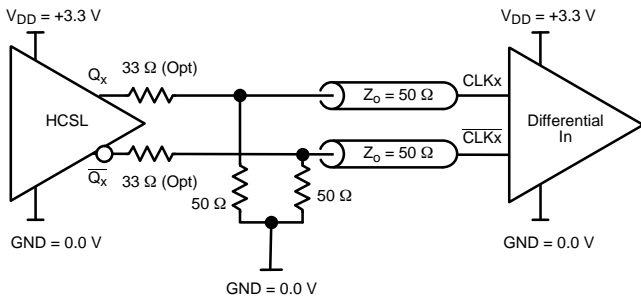

**Figure 11. CLK /  $\overline{\text{CLK}}$  Input Driven by a 3.3 V HCSL Driver**

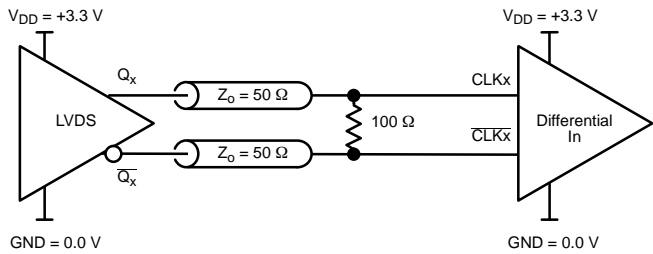

**Figure 12. CLK /  $\overline{\text{CLK}}$  Input Driven by 3.3 V LVDS Driver**

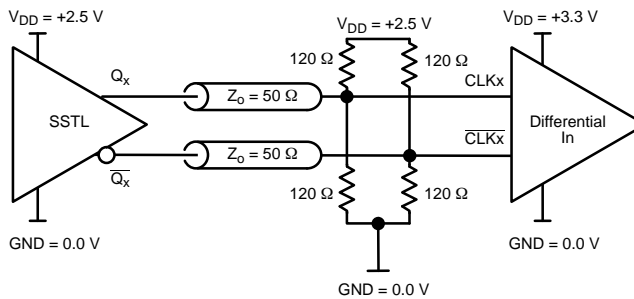

**Figure 13. CLK /  $\overline{\text{CLK}}$  Input Driven by 2.5 V SSTL Driver**

## NB3F8L3005C

### VFQFN EPAD Thermal Release Path

In order to maximize both the removal of heat from the package and the electrical performance, a land pattern must be incorporated on the Printed Circuit Board (PCB) within the footprint of the package corresponding to the exposed metal pad or exposed heat slug on the package, as shown in Figure 14. The solderable area on the PCB, as defined by the solder mask, should be at least the same size/shape as the exposed pad/slug area on the package to maximize the thermal/electrical performance. Sufficient clearance should be designed on the PCB between the outer edges of the land pattern and the inner edges of pad pattern for the leads to avoid any shorts. While the land pattern on the PCB provides a means of heat transfer and electrical grounding from the package to the board through a solder joint, thermal vias are necessary to effectively conduct from the surface of the PCB to the ground plane(s). The land pattern must be connected

to ground through these vias. The vias act as “heat pipes”. The number of vias (i.e. “heat pipes”) is application specific and dependent upon the package power dissipation as well as electrical conductivity requirements. Thus, thermal and electrical analysis and/or testing are recommended to determine the minimum number needed. Maximum thermal and electrical performance is achieved when an array of vias is incorporated in the land pattern. It is recommended to use as many vias connected to ground as possible. It is also recommended that the via diameter should be 12 to 13 mils (0.30 to 0.33 mm) with 1 oz copper via barrel plating. This is desirable to avoid any solder wicking inside the via during the soldering process which may result in voids in solder between the exposed pad/slug and the thermal land. Precautions should be taken to eliminate any solder voids between the exposed heat slug and the land pattern. Note: These recommendations are to be used as a guideline only.

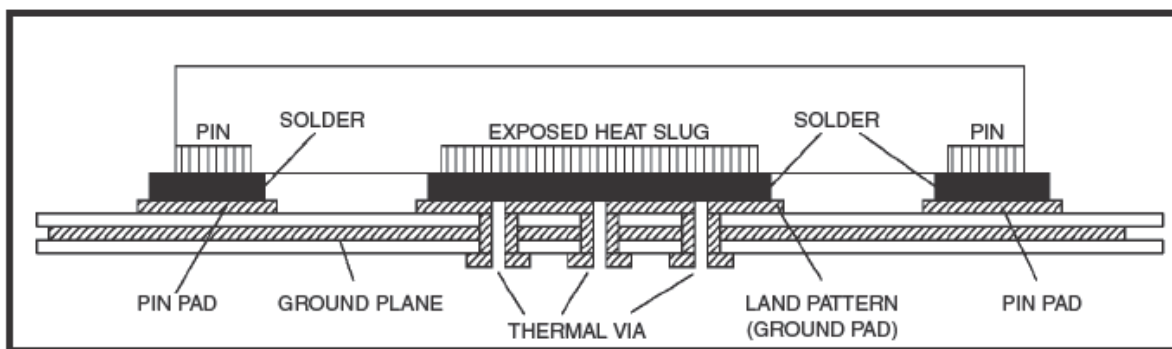

Figure 14. Suggested Assembly for Exposed Pad Thermal Release Path – Cut-away View (not to scale)

### ORDERING INFORMATION

Device	Package	Shipping†
NB3F8L3005CMNTXG	QFN24 (Pb-Free)	3000 / Tape & Reel
NB3F8L3005CMNTBG	QFN24 (Pb-Free)	1000 / Tape & Reel

†For information on tape and reel specifications, including part orientation and tape sizes, please refer to our Tape and Reel Packaging Specifications Brochure, BRD8011/D.

# NB3F8L3005C

## PACKAGE DIMENSIONS

QFN24, 4x4, 0.5P  
CASE 485DJ  
ISSUE O

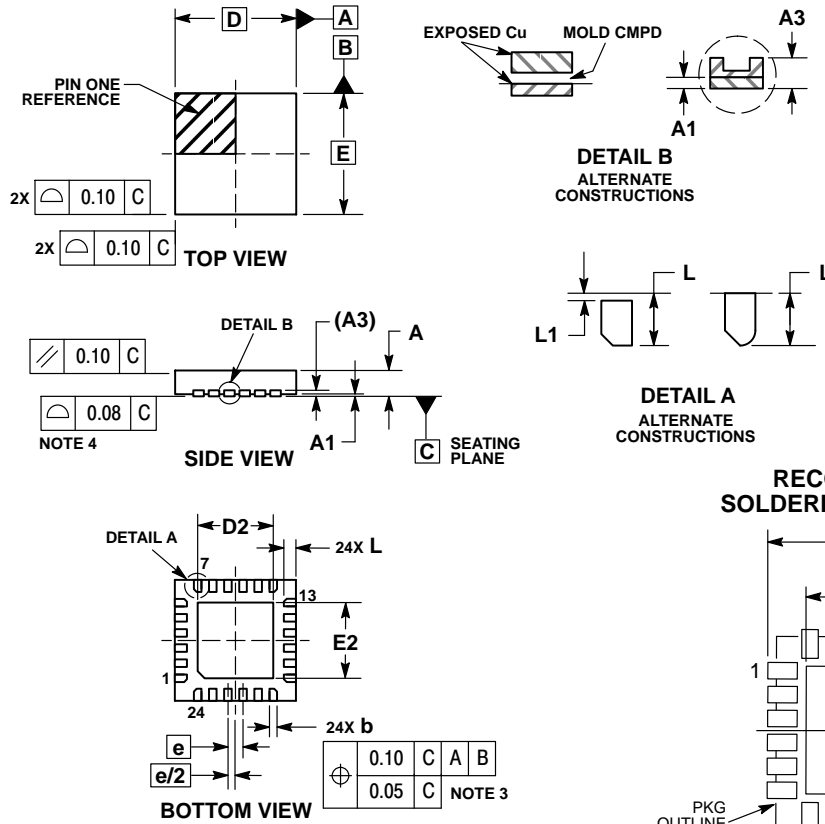

**NOTES:**

1. DIMENSIONING AND TOLERANCING PER ASME Y14.5M, 1994.
2. CONTROLLING DIMENSION: MILLIMETERS.
3. DIMENSION b APPLIES TO PLATED TERMINAL AND IS MEASURED BETWEEN 0.25 AND 0.30 MM FROM THE TERMINAL TIP.
4. COPLANARITY APPLIES TO THE EXPOSED PAD AS WELL AS THE TERMINALS.

DIM	MILLIMETERS	
	MIN	MAX
A	0.80	0.90
A1	0.00	0.05
A3	0.20	REF
b	0.20	0.30
D	4.00	BSC
D2	2.40	2.60
E	4.00	BSC
E2	2.40	2.60
e	0.50	BSC
L	0.30	0.50
L1	---	0.15

### RECOMMENDED SOLDERING FOOTPRINT\*

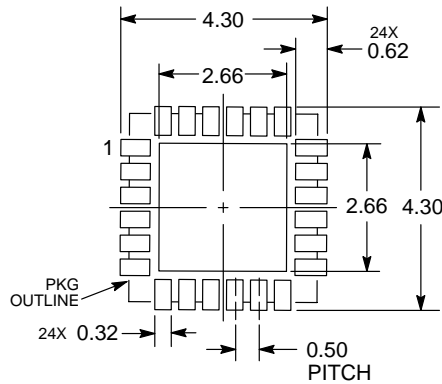

DIMENSIONS: MILLIMETERS

\*For additional information on our Pb-Free strategy and soldering details, please download the ON Semiconductor Soldering and Mounting Techniques Reference Manual, SOLDERRM/D.

ON Semiconductor and are registered trademarks of Semiconductor Components Industries, LLC (SCILLC). SCILLC owns the rights to a number of patents, trademarks, copyrights, trade secrets, and other intellectual property. A listing of SCILLC's product/patent coverage may be accessed at [www.onsemi.com/site/pdf/Patent-Marking.pdf](http://www.onsemi.com/site/pdf/Patent-Marking.pdf). SCILLC reserves the right to make changes without further notice to any products herein. SCILLC makes no warranty, representation or guarantee regarding the suitability of its products for any particular purpose, nor does SCILLC assume any liability arising out of the application or use of any product or circuit, and specifically disclaims any and all liability, including without limitation special, consequential or incidental damages. "Typical" parameters which may be provided in SCILLC data sheets and/or specifications can and do vary in different applications and actual performance may vary over time. All operating parameters, including "Typicals" must be validated for each customer application by customer's technical experts. SCILLC does not convey any license under its patent rights nor the rights of others. SCILLC products are not designed, intended, or authorized for use as components in systems intended for surgical implant into the body, or other applications intended to support or sustain life, or for any other application in which the failure of the SCILLC product could create a situation where personal injury or death may occur. Should Buyer purchase or use SCILLC products for any such unintended or unauthorized application, Buyer shall indemnify and hold SCILLC and its officers, employees, subsidiaries, affiliates, and distributors harmless against all claims, costs, damages, and expenses, and reasonable attorney fees arising out of, directly or indirectly, any claim of personal injury or death associated with such unintended or unauthorized use, even if such claim alleges that SCILLC was negligent regarding the design or manufacture of the part. SCILLC is an Equal Opportunity/Affirmative Action Employer. This literature is subject to all applicable copyright laws and is not for resale in any manner.

### PUBLICATION ORDERING INFORMATION

**LITERATURE FULFILLMENT:**  
Literature Distribution Center for ON Semiconductor  
P.O. Box 5163, Denver, Colorado 80217 USA  
Phone: 303-675-2175 or 800-344-3860 Toll Free USA/Canada  
Fax: 303-675-2176 or 800-344-3867 Toll Free USA/Canada  
Email: [orderlit@onsemi.com](mailto:orderlit@onsemi.com)

**N. American Technical Support:** 800-282-9855 Toll Free  
USA/Canada  
**Europe, Middle East and Africa Technical Support:**  
Phone: 421 33 790 2910  
**Japan Customer Focus Center**  
Phone: 81-3-5817-1050

**ON Semiconductor Website:** [www.onsemi.com](http://www.onsemi.com)  
**Order Literature:** <http://www.onsemi.com/orderlit>

For additional information, please contact your local Sales Representative

# Mouser Electronics

Authorized Distributor

Click to View Pricing, Inventory, Delivery & Lifecycle Information:

[ON Semiconductor:](#)

[NB3F8L3005CMNTXG](#) [NB3F8L3005CMNTBG](#)