

RoHS2(10 substances conformity)
 DRAWING FOR REFERENCE: This is subject to change without notice
 In cases where the application will demand a high level of reliability, such as automotive, please contact a company representative for further information.

TO
R

COUNT	DESCRIPTION OF REVISIONS	BY	CHKD	DATE	COUNT	DESCRIPTION OF REVISIONS	BY	CHKD	DATE
△					△				
△					△				
APPLICABLE STANDARD									
RATING	OPERATING TEMPERATURE RANGE	-25 °C TO +85 °C			STORAGE TEMPERATURE RANGE	-10 °C TO +60 °C			
	VOLTAGE	AC 100 V, DC 140 V							
	CURRENT	2 A			APPLICABLE CABLE	(φ 6)			
SPECIFICATIONS									
ITEM		TEST METHOD			REQUIREMENTS			QT	AT
CONSTRUCTION									
GENERAL EXAMINATION		VISUALLY AND BY MEASURING INSTRUMENT.			ACCORDING TO DRAWING.			×	×
MARKING		CONFIRMED VISUALLY.						×	×
ELECTRIC CHARACTERISTICS									
CONTACT RESISTANCE		CONTACT SHALL BE MEASURED AT DC 1 A			10 mΩ MAX.			×	×
INSULATION RESISTANCE		100 V DC.			1000 MΩ MIN.			×	×
VOLTAGE PROOF		300 V AC FOR 1 min.			NO FLASHOVER OR BREAKDOWN.			×	×
MECHANICAL CHARACTERISTICS									
CONTACT INSERTION AND WITHDRAWAL FORCES		φ 0.53 ± 0.003 BY STEEL GAUGE.			INSERTION AND WITHDRAWAL FORCES : 0.15 N MIN.			×	—
CONNECTOR INSERTION AND WITHDRAWAL FORCES		MEASURED BY APPLICABLE CONNECTOR.			INSERTION AND WITHDRAWAL FORCES LOCKING DEVICE WITH LOCK : 70 N MAX.			×	—
MECHANICAL OPERATION		1000 TIMES INSERTIONS AND EXTRACTIONS.			CONTACT RESISTANCE: 15 mΩ MAX.			×	—
VIBRATION		FREQUENCY 10 TO 55 Hz, SINGLE AMPLITUDE 0.75 mm, — m/s ² AT 2 h, FOR 3 DIRECTIONS.			① NO ELECTRICAL DISCONTINUITY OF 10 μs. ② NO DAMAGE, CRACK AND LOOSENESS, OF PARTS.			×	—
SHOCK		490 m/s ² DIRECTIONS OF PULSE 11 ms AT 3 TIMES FOR 3 DIRECTIONS.			① NO ELECTRICAL DISCONTINUITY OF 10 μs. ② NO DAMAGE, CRACK AND LOOSENESS, OF PARTS.			×	—
ENVIRONMENTAL CHARACTERISTICS									
DAMP HEAT (STEADY STATE)		EXPOSED AT 40 °C, 90 TO 95 %, 96 h.			① INSULATION RESISTANCE: 5 MΩ MIN (AT HIGH HUMIDITY). ② INSULATION RESISTANCE: 50 MΩ MIN (AT DRY). ③ NO DAMAGE, CRACK AND LOOSENESS OF PARTS.			×	—
RAPID CHANGE OF TEMPERATURE		TEMPERATURE -55 → R/T ⁽¹⁾ → +85 → R/T °C TIME 30 → 10 TO 15 → 30 → 10 TO 15 min UNDER 5 CYCLES.			① INSULATION RESISTANCE: 1000 MΩ MIN. ② NO DAMAGE, CRACK AND LOOSENESS OF PARTS.			×	—
CORROSION SALT MIST		EXPOSED IN 5 % SALT WATER SPRAY FOR 48 h.			NO HEAVY CORROSION.			×	—
DRY HEAT		EXPOSED AT + 85 °C, 96 h.			NO DAMAGE, CRACK AND LOOSENESS OF PARTS.			×	—
COLD		EXPOSED AT - 55 °C, 96 h.			NO DAMAGE, CRACK AND LOOSENESS OF PARTS.			×	—
RESISTANCE TO SOLDERING HEAT		SOLDER TEMPERATURE, + 380 ± 10 °C, FOR SOLDERING DURATION, 3 ~ 4 s.			NO DEFORMATION OF CASE OF EXCESSIVE LOOSENESS OF THE TERMINALS.			×	—
SOLDERABILITY		SOLDERED AT SOLDER TEMPERATURE, + 350 ± 10 °C FOR SOLDERING DURATION, 2 ~ 3 s.			WETTING ON SOLDER SURFACE. NO SOLDER CLUSTER.			×	—
REMARKS					DRAWN	DESIGNED	CHECKED	APPROVED	RELEASED
NOTE (1) R/T : ROOM TEMPERATURE					J. Kamata	D. Matsuda	E. Kunii	M. Sato	
Unless otherwise specified, refer to JIS C 5402.					05.12.20	05.12.20	05.12.20	05.12.21	
Note QT:Qualification Test AT:Assurance Test ×:Applicable Test									
HRS HIROSE ELECTRIC CO., LTD.					SPECIFICATION SHEET			PART NO. HR10A-10LP-12S(73)	
CODE NO. (OLD)		DRAWING NO.			CODE NO.			1/1	
CL		ELC4-044627-73			CL110-0458-4-73				



2018/12/05 03:14:17(JST) Rachelle Sheffer
 RoHS2(10 substances conformity)
 DRAWING FOR REFERENCE: This is subject to change without notice
 In cases where the application will demand a high level of reliability, such as automotive, please contact a company representative for further information.

COUNT	DESCRIPTION OF REVISIONS	BY	CHKD	DATE	COUNT	DESCRIPTION OF REVISIONS	BY	CHKD	DATE
△				..	△				..
△				..	△				..
△				..	△				..

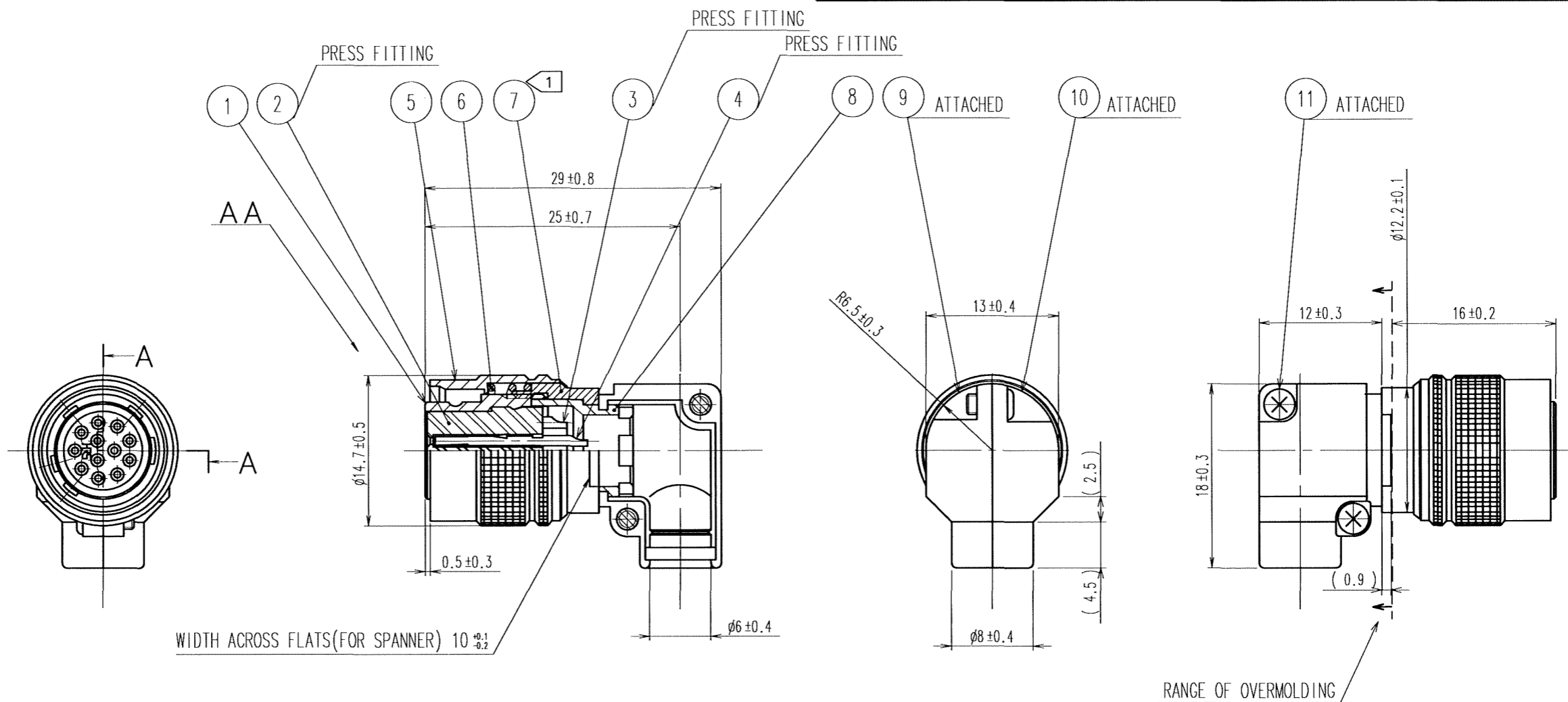

NOTE ① THE RECOMMENDED CLAMP TORQUE OF REF.NO⑦ TO BE 0.2N·m
 LOCTITE 242, HENKEL JAPAN OR EQUIVALENT IS RECOMMENDED TO PREVENT REF.NO⑦ FOR LOOSENING.
 ② REF.NO⑨ AND ⑩ AND ⑪ ARE ATTACHED PARTS.
 ③ ONE EXAMPLE OF THE ROTATION OF REF.NO⑦ TO REF.NO④ IS SHOWN.
 ④ GOLD PLATING : 0.2μm min.
 NICKEL UNDER PLATING : 2μm min.

6	STEEL	NICKEL PLATING		
5	BRASS	BLACK CHROME PLATING	11	STEEL NICKEL PLATING CROSS RECESSED HEAD TAPPING SCREW M2X5
4	PHOSPHOR BRONZE	④	10	ZINC ALLOY MATTE FINISH NICKEL PLATED
3	PHOSPHOR BRONZE	④	9	ZINC ALLOY MATTE FINISH NICKEL PLATED
2	POLYAMIDE	(BLACK) UL94V-0	8	BRASS NICKEL PLATING
1	ZINC ALLOY	MATTE FINISH NICKEL PLATED	7	BRASS NICKEL PLATING
NO.	MATERIAL	FINISH, REMARKS	NO.	MATERIAL FINISH, REMARKS

CODE NO. (OLD) CL	DRAWN <i>O. Kowata</i> 05.12.20	DESIGNED <i>D. Motome</i> 05.12.20	CHECKED <i>E. Kunii</i> 05.12.20	APPROVED <i>M. Sato</i> 05.12.21	RELEASED ..
DRAWING NO. EDC3-044627-73		PART NO. HR10A-10LP-12S(73)			
SCALE 2 : 1	UNITS mm		CODE NO. CL110-0458-4-73		1/1

TO
R