

THIS DRAWING IS UNPUBLISHED.

RELEASED FOR PUBLICATION NOV. 2006.

© COPYRIGHT 2006 By -

ALL RIGHTS RESERVED.

LOC	DIST	REVISIONS					
E	B	P	LTR	DESCRIPTION	DATE	DWN	APVD
		C		REVISED PER ECO-12-017394	16JAN13	GG	MY

NOTES

- 1 SINGLE PACK IN ACCORDANCE WITH AMP SPEC 107-3275
- 2 100 TRAY PACK IN ACCORDANCE WITH AMP SPEC 107-3275
- 3 Ni PLATING
- 4 TIN PLATING
- 5. FOR TECHNICAL DATA REFER TO YOUR LOCAL TE CONNECTIVITY SALES OFFICE
- 6. ALL DIMENSIONS ARE NOMINAL FOR REFERENCE ONLY UNLESS OTHERWISE STATED

9-1478243-0	8.30	9.30	8.30	7.00	5.70	CT125	5-1814826-7
9-1478243-0	8.30	9.30	8.30	7.00	5.70	CT125	5-1814826-6
9-1478242-0	6.50	7.50	6.70	5.60	4.60	CT100	5-1814826-5
9-1478242-0	6.50	7.50	6.70	5.60	4.60	CT100	5-1814826-4
9-1478243-0	8.60	9.60	8.70	6.80	4.85	RG6/U	5-1814826-3
9-1478243-0	8.60	9.60	8.70	6.80	4.85	RG6/U	5-1814826-2
9-1478242-0	6.50	7.50	6.80	4.90	3.90	RG59B/U, 62A/U, 140/U, 210/U, URM90, Belden 9291, 9291, KX6A, KX25, KX52, KX53	5-1814826-1
9-1478242-0	6.50	7.50	6.60	4.90	3.90	RG59B/U, 62A/U, 140/U, 210/U, URM90, Belden 9291, 9291, KX6A, KX25, KX52, KX53	5-1814826-0
DIE SET	E	D	C	B	A	CABLE GROUPS	PART NO.
DIMENSIONS							

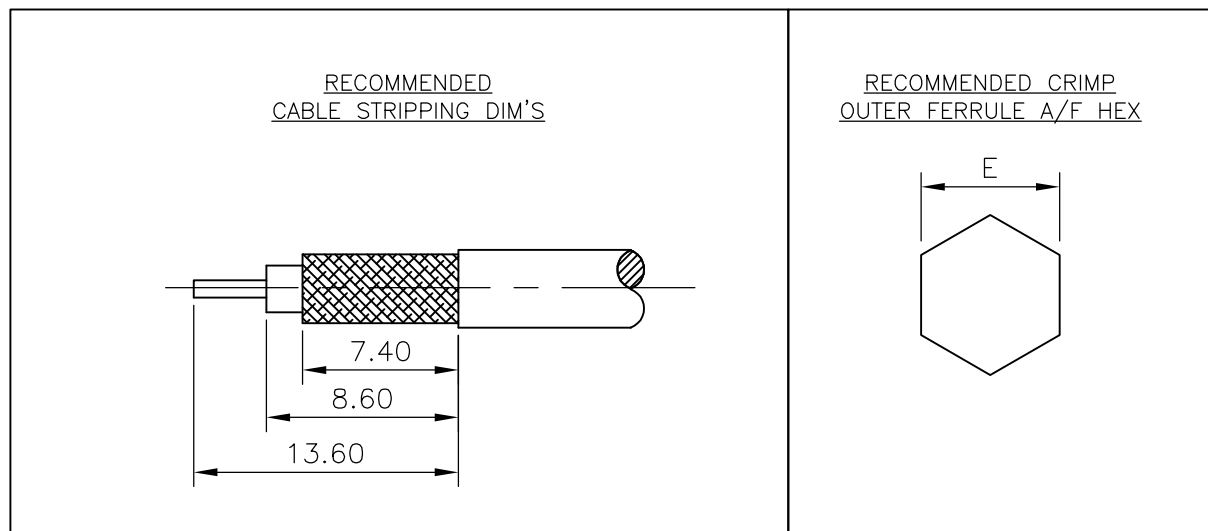
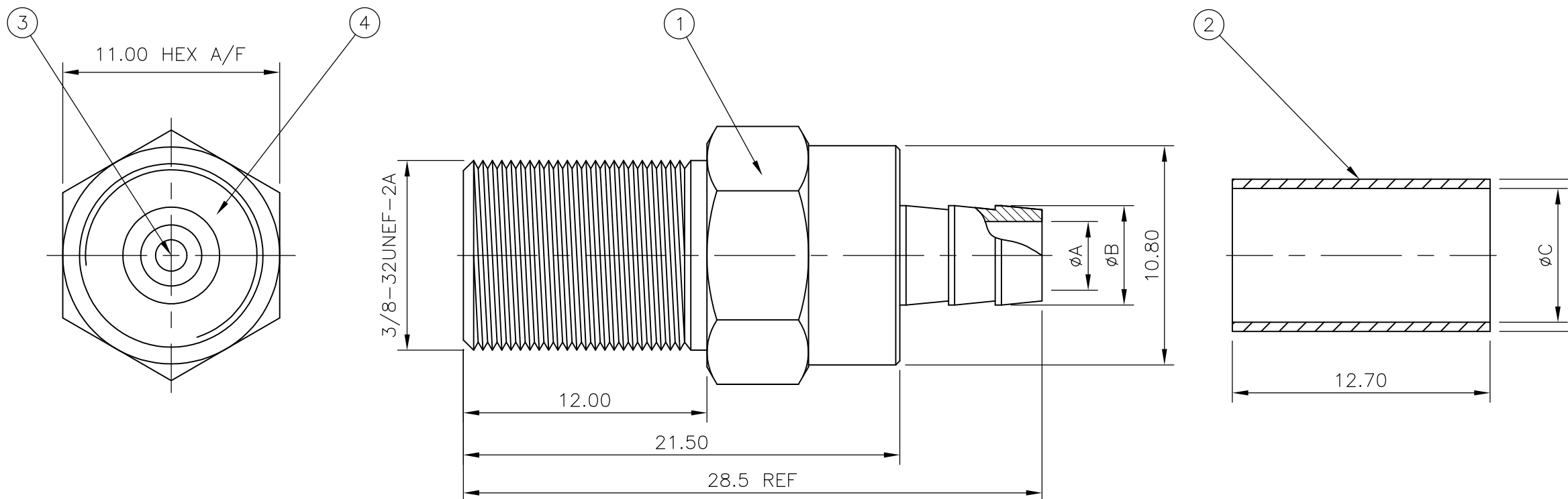

OBSOLETE												
1	1	1	1	1	1	1	1	1	1	POLYPROPYLENE	INSULATOR	4
1	1	1	1	1	1	1	1	1	1	BRASS	CONTACT	3
1	1	1	1	1	1	1	1	1	1	ZINC ALLOY	FERRULE	2
1	1	1	1	1	1	1	1	1	1	BRASS	BODY	1
5	75	65	55	45	35	25	15	0		MATERIAL	DESCRIPTION	ITEM
										QUANTITY PER ASSY		
										PARTS LIST		

THIS DRAWING IS A CONTROLLED DOCUMENT.

DIMENSIONS: mm	TOLERANCES UNLESS OTHERWISE SPECIFIED:	DWN ANSON MA 14FEB09	STE TE Connectivity	
	0 PLC ± - 1 PLC ± - 2 PLC ± 0.3 3 PLC ± - 4 PLC ± - ANGLES ± -	CHK RITA ZUO 14FEB09		
MATERIAL SEE TABLE	FINISH -	APVD BOB ZHAO 14FEB09	NAME F TYPE BLK JK R/M	
		PRODUCT SPEC 108-112000		
		APPLICATION SPEC -	SIZE A3	CAGE CODE 00779
		WEIGHT -	DRAWING NO C-1814826	RESTRICTED TO -
CUSTOMER DRAWING			SCALE NTS	SHEET 1 OF 1
			REV C	

Mouser Electronics

Authorized Distributor

Click to View Pricing, Inventory, Delivery & Lifecycle Information:

[TE Connectivity:](#)

[5-1814826-3](#)