

**RDS100-24**

SPECIFICATIONS

B029-01-01D

ITEMS		MODEL	RDS100-24-5	RDS100-24-12	RDS100-24-15	RDS100-24-24
1	Nominal Output Voltage	V	5	12	15	24
2	Maximum Output Current	A	20	8.3	6.6	4.2
3	Maximum Output Power	W	100	99.6	99	100.8
4	Efficiency (Typ) (*1)	%	78	79		80
5	Input Voltage Range	-	18 - 32VDC			
6	Input Current (Typ) (*1)	A	5.4			
7	Inrush Current (Typ) (*1)	-	4.7A at Cold Start			
8	Output Voltage Range (*8)	V	4.0 - 6.0	9.6 - 14.4	12.0 - 18.0	19.2 - 28.8
9	Maximum Ripple (*2)	mV	50	80	80	100
10	Maximum Ripple & Noise (*2)	mV	100	170	200	290
11	Maximum Line Regulation (*3)	mV	40	96	120	192
12	Maximum Load Regulation (*4)	mV	50	100	100	200
13	Temperature Coefficient	-	Less than 0.02 %/°C			
14	Over Current Protection (*5)	A	22 - 24	9.3 - 9.9	7.4 - 7.9	4.7 - 5.1
15	Over Voltage Protection (*6)	V	6.2 - 7.5	15.0 - 18.0	18.5 - 22.5	29.5 - 36.0
16	Remote ON/OFF control	-	Possible			
17	Parallel Operation	-	-			
18	Series Operation	-	Possible			
19	Operating Temperature (*7)	-	-20 - +60°C (-20 - +50°C:100%, +60°C:70%)			
20	Operating Humidity	-	20 - 95%RH (No Condensing)			
21	Storage Temperature	-	-25 - +75°C			
22	Storage Humidity	-	20 - 95%RH (No Condensing)			
23	Cooling	-	Convection Cooling			
24	Withstand Voltage	-	I/P - O/P, I/P - FG : 2kVAC (10mA) for 1min., O/P - CNT(RC) : 100VAC (100mA) for 1min.			
25	Isolation Resistance	-	O/P - FG : 500VDC 100Mohm, O/P - CNT(RC) : 100VDC 10Mohm			
26	Vibration	-	10 - 55Hz : 19.6m/s <sup>2</sup> , X,Y,Z 1hour each. Designed to meet JIS E 3014-2-B			
27	Shock	-	294m/s <sup>2</sup> (time : 6 ± 3ms) Designed to meet JIS E 3015-2-B			
28	Safety	-	Approved by UL60950-1 & CSA60950-1, Designed to meet EN60950-1			
29	Conducted Emission	-	Designed to meet EN55011/EN55022-A, FCC-ClassA, VCCI-A			
30	Radiated Emission	-	Designed to meet EN55011/EN55022-A, FCC-ClassA, VCCI-A			
31	Immunity	-	Designed to meet IEC61000-4-2(Level 2,3), -4(Level 3), -8(Level 4)			
32	Weight (Typ)	g	850			
33	Size (W x H x D)	mm	60 x 95 x 220 ( Refer to Outline Drawing )			

\*Read instruction manual carefully, before using the power supply unit.

=NOTES=

- \*1. At 24VDC, Ta=25°C, nominal output voltage and maximum output power.
- \*2. Measure with JEITA RC-9131A probe, Bandwidth of scope :100MHz.
- \*3. 18 - 32VDC, constant load.
- \*4. No load-Full load, constant input voltage.
- \*5. OCP TYPE : Constant current limit with automatic recovery.
- \*6. OVP circuit will shut the output down, manual reset (Re power on).
- \*7. Ratings
  - Derating at standard mounting. Refer to output derating curve(B029-01-02\_).
  - Load (%) is percent of maximum output power or maximum output current, whichever is greater.
- \*8. At 24VDC Input.(Refer to instruction manual.)

**RDS100-24**

OUTPUT DERATING

B029-01-02A

\*COOLING : CONVECTION COOLING

Ta (°C)	LOAD (%)	
	MOUNTING A	MOUNTING B
-20 - +40	100	100
50	100	70
60	70	-

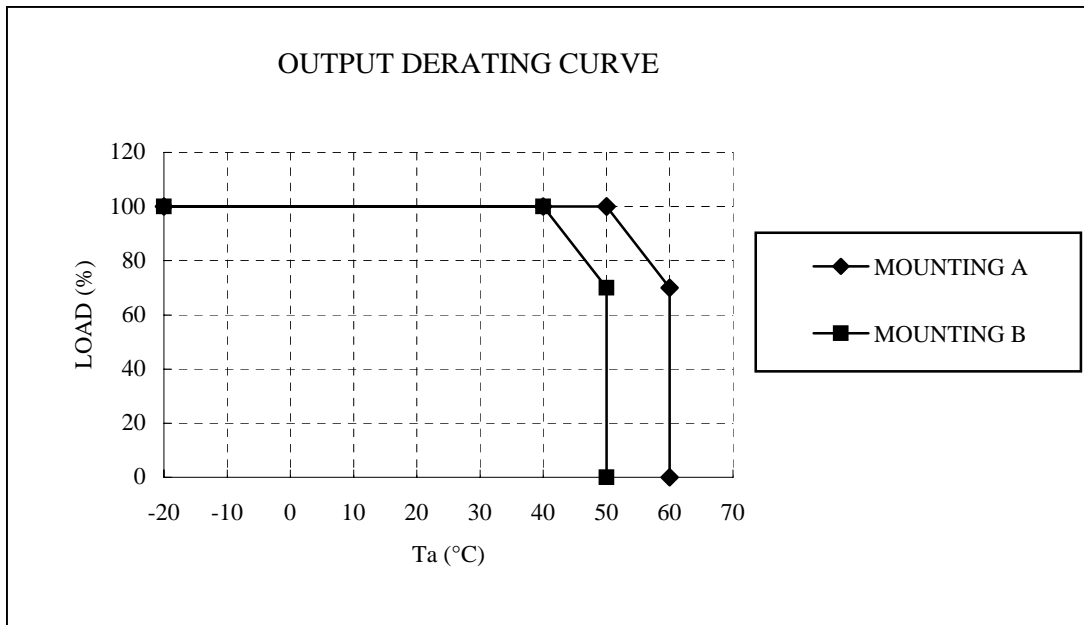

DON'T USE

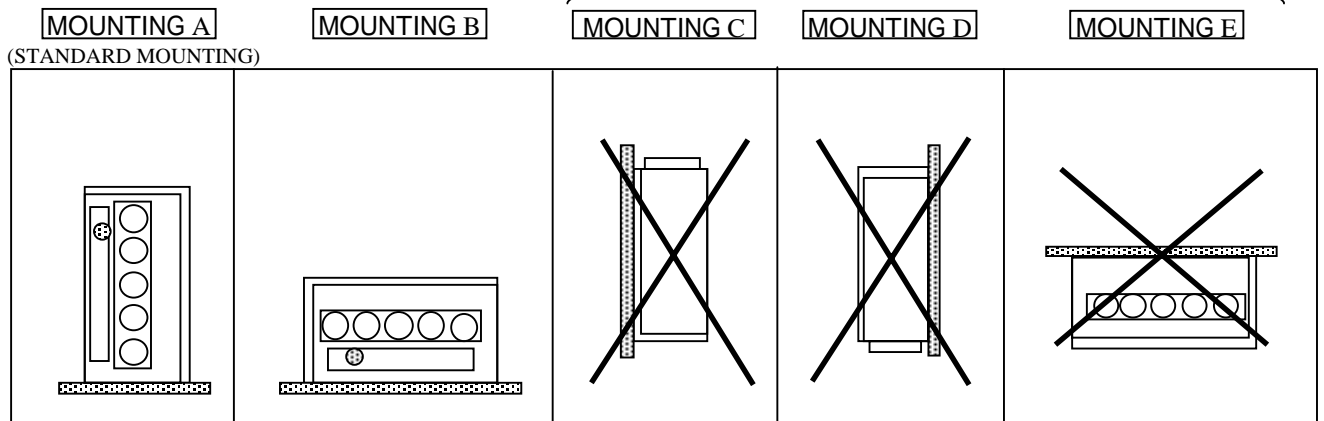

# Mouser Electronics

Authorized Distributor

Click to View Pricing, Inventory, Delivery & Lifecycle Information:

[TDK-Lambda:](#)

[RDS1002412](#)