

THIS DOCUMENT IS THE PROPERTY OF
KEYSTONE ELECTRONICS CORP. AND
SHALL NOT BE REPRODUCED, DISTRIBUTED
OR USED AS A BASIS FOR MANUFACTURE
WITHOUT PRIOR WRITTEN PERMISSION
FROM KEYSTONE ELECTRONICS CORP.

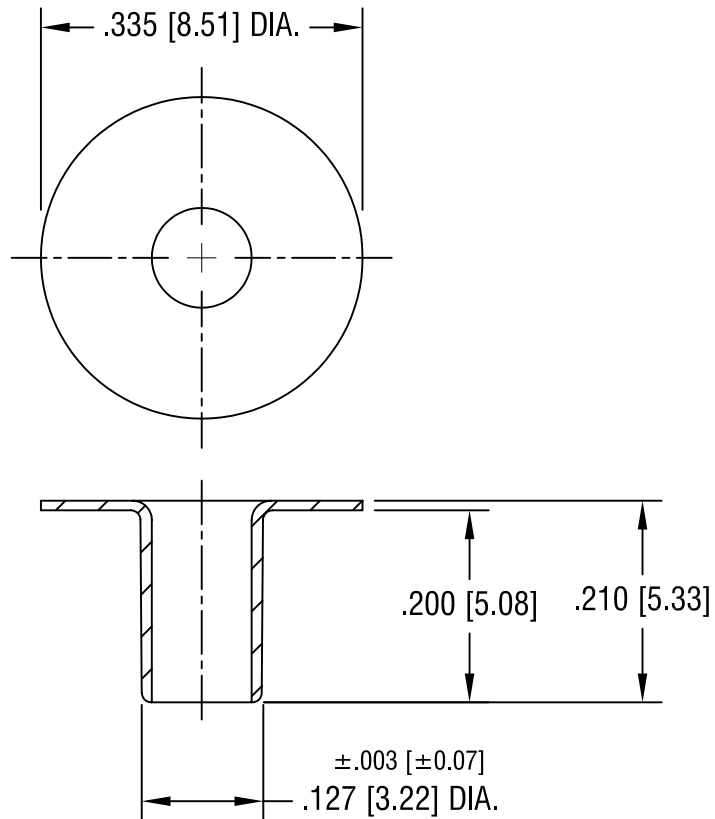

| | | | |
|-----------------------------------|-----------------|------------------------|-------------|
| KEYSTONE ELECTRONICS CORP. | | | |
| ASTORIA, N.Y. 11105-2017 | | | |
| PART NAME | | CONTACT EYELET | |
| MATERIAL | | .010 [0.25] TH'K BRASS | |
| FINISH | | DRN BY | DATE |
| NICKEL PLATE | | BOONE | 4.19.82 |
| | | APP'D | SCALE |
| | | LN | 5X |
| TOLERANCES | INCH [MM] | CODE | DWG NO. |
| DECIMAL | ± .005 [± 0.15] | C | 4021 |
| ANGULAR | ± 1° | | |
| UNLESS OTHERWISE SPECIFIED | | | |

| | | |
|---------|-------------|------|
| 7.30.86 | REVISED | A |
| DATE | DESCRIPTION | REV. |

Mouser Electronics

Authorized Distributor

Click to View Pricing, Inventory, Delivery & Lifecycle Information:

[Keystone Electronics:](#)

[4021](#)