

Description

The [SP3494](#) device is a 3.3V low power half-duplex transceiver that meets the specifications of the RS-485 and RS-422 serial protocols. This device is pin-to-pin compatible with the MaxLinear SP3481 device as well as other popular industry standards. The SP3494 features the MaxLinear BiCMOS process, allowing low power operation without sacrificing performance. The partially slew-rate limited drivers minimize EMI and reduce reflections caused by improperly terminated cables allowing error-free data transmission. The SP3494 is a half-duplex partially slew-rate limited transceiver that will deliver a data transmission rate up to 2.5Mbps. The SP3494 is equipped with a low-power shutdown mode and driver/receiver high-Z enable lines.

FEATURES

- Operates from a single 3.3V supply
- Interoperable with 5.0V logic
- $\pm 200\text{mV}$ receiver input sensitivity
- -7V to $+12\text{V}$ common-mode input voltage range
- Allows up to 32 transceivers on the serial bus
- Driver/receiver enable lines
- $10\mu\text{A}$ low-power shutdown mode
- Compatibility with the MAX3486 and 75176 industry standard pinout

Ordering Information - [Back Page](#)

Block Diagram

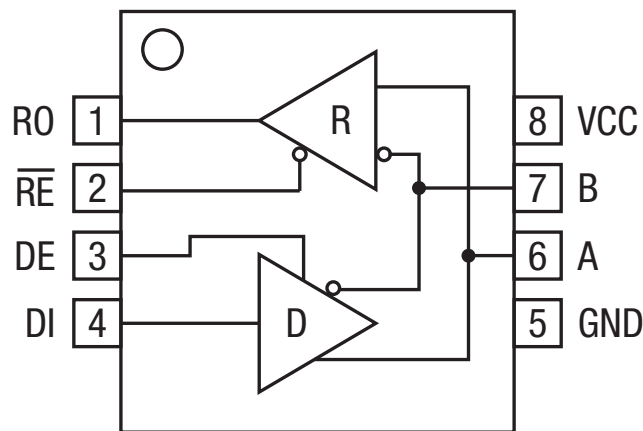

SP3494

Absolute Maximum Ratings

These are stress ratings only and functional operation of the device at these ratings or any other above those indicated in the operation sections of the specifications below is not implied. Exposure to absolute maximum rating conditions for extended periods of time may affect reliability.

V_{CC} 6.0V

Input Voltages

Drivers -0.3V to 6.0V

Receivers ±14V

Output Voltages

Drivers +/-14V

Receivers -0.3V to 6.0V

Storage Temperature -65°C to +150°C

Maximum Junction Temperature, T_J 125°C

Power Dissipation

8-pin NSOIC 600mW

(derate 6.90mW/°C above +70°C)

Operating Conditions

Package Power Dissipation

8-pin NSOIC Θ_{JA} 128.4°C/W

ESD Rating

Human Body Model (HBM) ±2kV

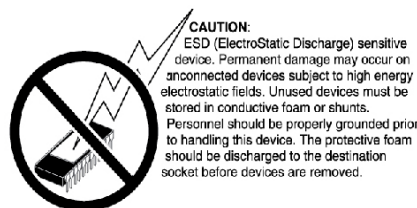

Electrical Characteristics

T_{AMB} = T_{MIN} to T_{MAX} and V_{CC} = 3.3V ±5% unless otherwise noted.

PARAMETERS	MIN.	TYP.	MAX.	UNITS	CONDITIONS
SP3494 Driver DC Characteristics					
Differential output voltage			V _{CC}	V	Unloaded; R = ∞Ω ; Figure 1
Differential output voltage	2		V _{CC}	V	With load; R = 50Ω (RS-422); Figure 1
Differential output voltage	1.5		V _{CC}	V	With load; R = 27Ω (RS-485); Figure 1
Change in magnitude of driver differential output voltage for complimentary states			0.2	V	R = 27Ω or R = 50Ω; Figure 1
Driver common-mode output voltage			3	V	R = 27Ω or R = 50Ω; Figure 1
Input high voltage	2.0			V	Applies to DE, DI, RE
Input low voltage			0.8	V	Applies to DE, DI, RE
Input current			±10	μA	Applies to DE, DI, RE
Driver short circuit current V _{out} = HIGH			±250	mA	-7V ≤ V _O ≤ +12V; Figure 8
Driver short circuit current V _{out} = LOW			±250	mA	-7V ≤ V _O ≤ +12V; Figure 8
SP3494 Driver AC Characteristics					
Maximum data rate	2.5			Mbps	RE = V _{CC} , DE = V _{CC}
Driver input to output, t _{plh}	20	45	75	ns	Figures 2 & 9
Driver input to output, t _{phl}	20	45	75	ns	Figures 2 & 9
Differential driver skew		10		ns	t _{DO1} - t _{DO2} , Figures 2 and 10
Driver rise or fall time		30	70	ns	From 10%-90%; Figures 3 and 10

Electrical Characteristics (Continued)

$T_{AMB} = T_{MIN}$ to T_{MAX} and $V_{CC} = 3.3V \pm 5\%$ unless otherwise noted.

PARAMETERS	MIN.	TYP.	MAX.	UNITS	CONDITIONS
SP3494 Driver AC Characteristics (Continued)					
Driver enable to output high		52	120	ns	Figures 4 and 11
Driver enable to output low		60	120	ns	Figures 5 and 11
Driver disable time from low		40	120	ns	Figures 5 and 11
Driver disable time from high		60	120	ns	Figures 4 and 11
SP3494 Receiver DC Characteristics					
Differential input threshold	-0.2		0.2	Volts	$-7V \leq V_{CM} \leq 12V$
Input hysteresis		20		mV	$V_{CM} = 0V$
Output voltage HIGH	$V_{CC}-0.4$			Volts	$V_{ID} = +200mV, -1.5mA$
Output voltage LOW			0.4	Volts	$V_{ID} = -200mV, 2.5mA$
Three-state (high impedance) output current			± 1	μA	$0V \leq V_O \leq V_{CC}; \overline{RE} = V_{CC}$
Input resistance	12	15		k Ω	$-7V \leq V_{CM} \leq 12V$
Input current (A, B); $V_{IN} = 12V$			1.0	mA	$DE = 0V, V_{CC} = 0V$ or $3.6V, V_{IN} = 12V$
Input current (A, B); $V_{IN} = -7V$			-0.8	mA	$DE = 0V, V_{CC} = 0V$ or $3.6V, V_{IN} = -7V$
Short circuit current	7		60	mA	$0V \leq V_{CM} \leq V_{CC}$
SP3494 Receiver AC Characteristics					
Maximum data rate	2.5			Mbps	$\overline{RE} = 0V, DE = 0V$
Receiver input to output, t_{PLH}	40	70	100	ns	Figures 6 and 12
Receiver input to output, t_{PHL}	40	70	100	ns	Figures 6 and 12
Differential receiver skew		10		ns	$t_{RSKEW} = t_{RPHL} - t_{RPLH} $, Figures 6 and 12
Receiver enable to output low		35	60	ns	Figures 7 and 13, S_1 closed, S_2 open
Receiver enable to output high		35	60	ns	Figures 7 and 13, S_2 closed, S_1 open
Receiver disable from low		35	60	ns	Figures 7 and 13, S_1 closed, S_2 open
Receiver disable from high		35	60	ns	Figures 7 and 13, S_2 closed, S_1 open

Electrical Characteristics, Continued

T_{AMB} = T_{MIN} to T_{MAX} and V_{CC} = 3.3V ±5% unless otherwise noted.

PARAMETERS	MIN.	TYP.	MAX.	UNITS	CONDITIONS
SP3494 Shutdown Timing					
Time to shutdown	50	75	200	ns	$\overline{RE} = 3.3V, DE = 0V$
Driver enable from shutdown to output high		65	150	ns	Figures 4 and 11
Driver enable from shutdown to output low		65	150	ns	Figures 5 and 11
Receivers enabled from shutdown to output high		50	200	ns	Figures 7 and 13, S ₂ closed, S ₁ open
Receivers enabled from shutdown to output low		50	200	ns	Figures 7 and 13, S ₁ closed, S ₂ open
Power Requirements					
Supply current, no load		1000	2000	μA	$\overline{RE}, DI = 0V$ or V _{CC} ; DE = V _{CC}
Supply current, no load		800	1500	μA	$\overline{RE} = 0V, DI = 0V$ or V _{CC} , DE = 0V
Shutdown mode			10	μA	DE = 0V, $\overline{RE} = V_{CC}$

Pin Functions

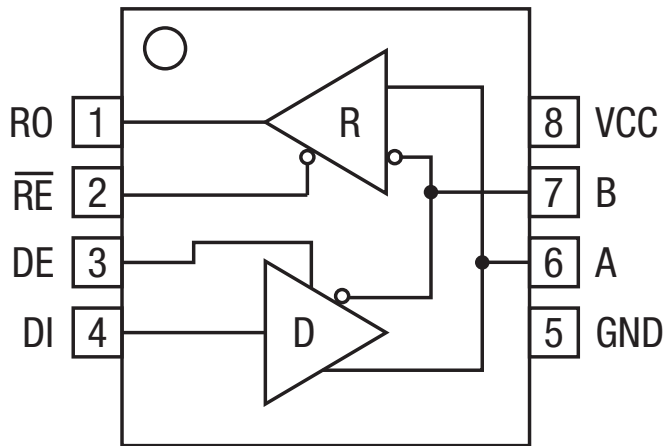

SP3494
Pinout (Top View)

Pin Number	Pin Name	Description
1	RO	Receiver output
2	\overline{RE}	Receiver Output Enable Active LOW
3	DE	Driver Output Enable Active HIGH
4	DI	Driver Input
5	GND	Ground Connection
6	A	Non-Inverting Driver Output / Receiver Input
7	B	Inverting Driver Output / Receiver Input
8	VCC	Positive Supply 3.3V ±5%

Test Circuits

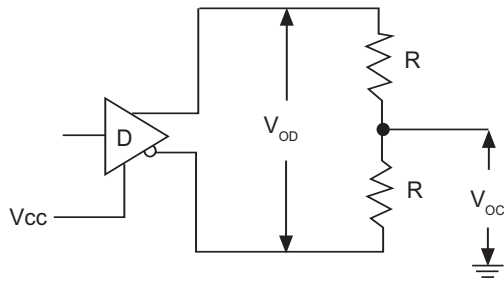

Figure 1. Driver DC Test Load Circuit

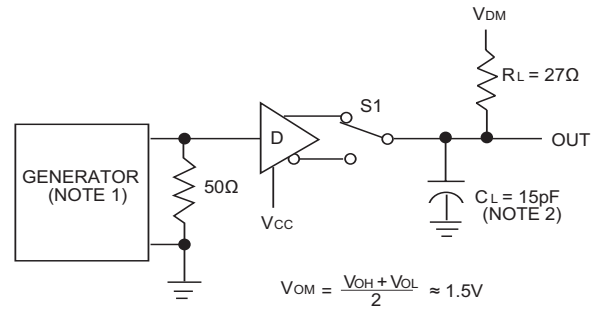

Figure 2. Driver Propagation Delay Test Circuit

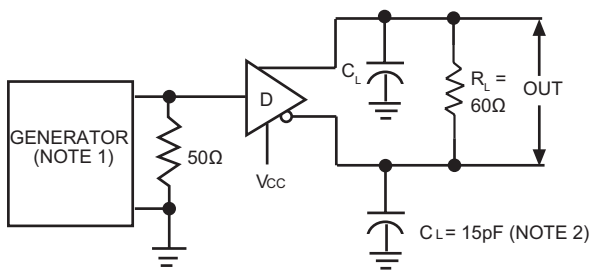

Figure 3. Driver Differential Output Delay and Transition Time Circuit.

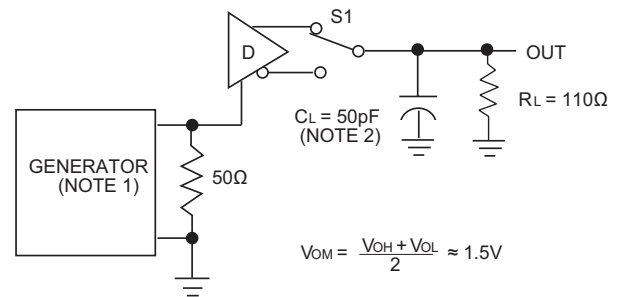

Figure 4. Driver Enable and Disable Timing Circuit, Output High

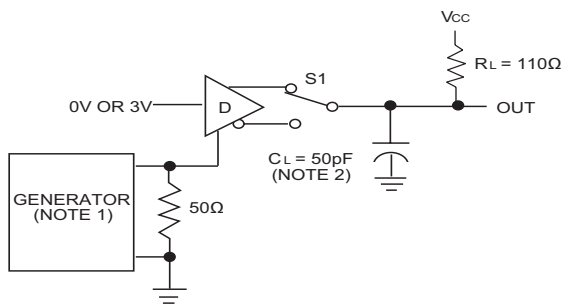

Figure 5. Driver Enable and Disable Timing Circuit, Output Low

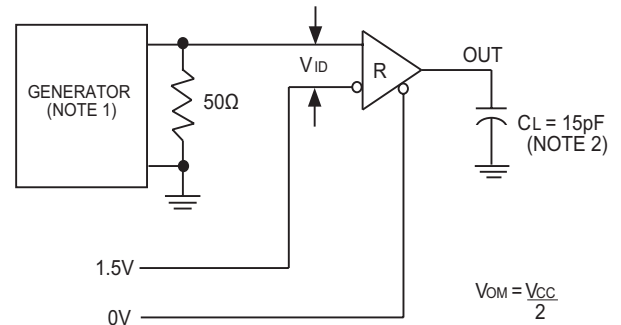

Figure 6. Receiver Propagation Delay Test Circuit

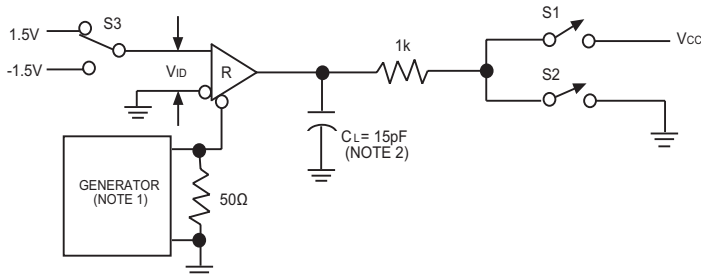

Figure 7. Receiver Enable and Disable Timing Circuit

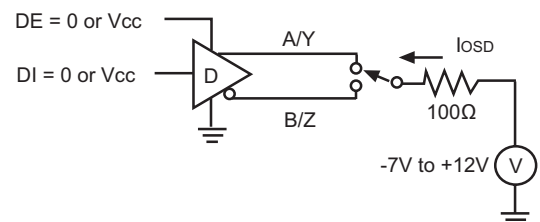

Figure 8. Driver Short Circuit Current Limit Test

NOTES

- 1: The input pulse is supplied by a generator with the following characteristics:
 PRR = 250kHz, 50% duty cycle, $t_r < 6.0ns$, $Z_0 = 50\Omega$.
- 2: C_L includes probe and stray capacitance.

Switching Waveforms

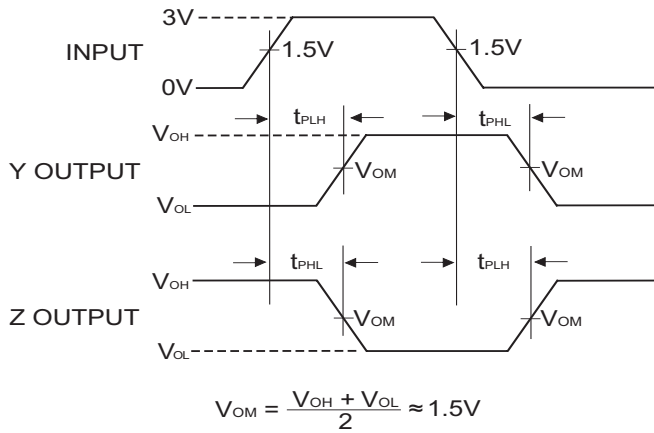

Figure 9. Driver Propagation Delay Waveforms

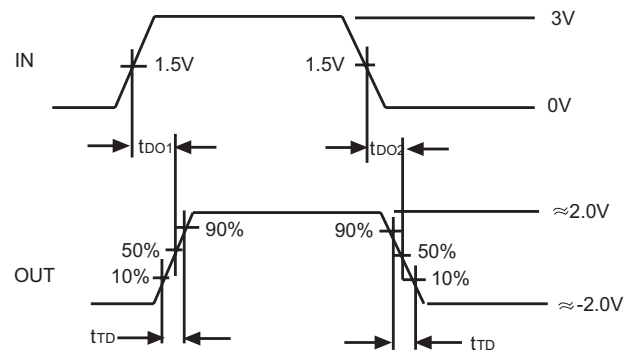

Figure 10. Driver Differential Output Delay and Transition Time Waveforms

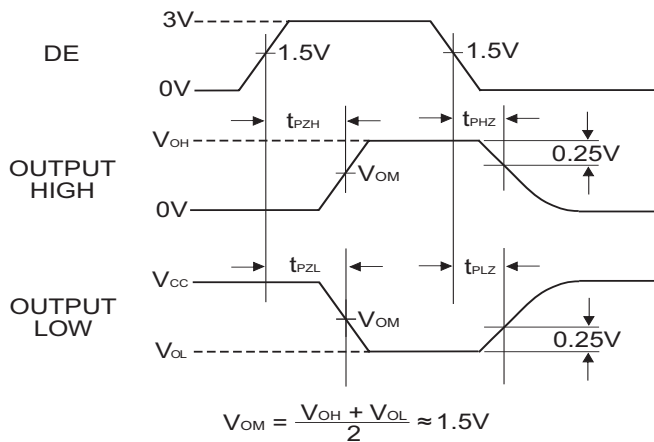

Figure 11. Driver Enable and Disable Timing Waveforms

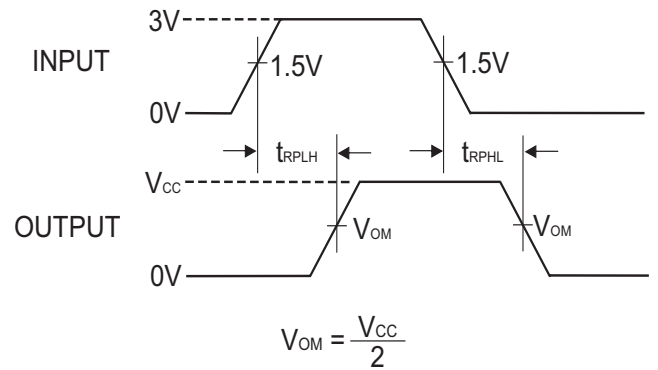

Figure 12. Receiver Propagation Delay Waveforms

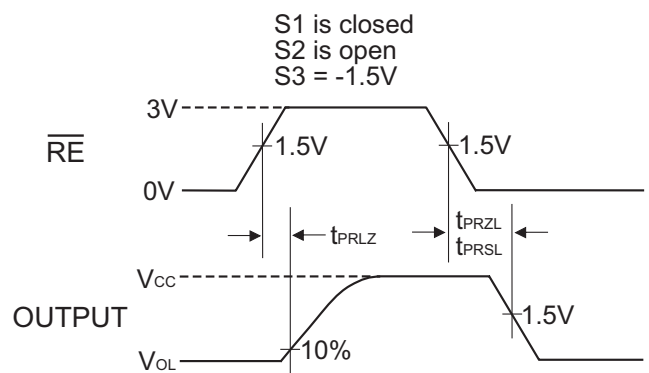
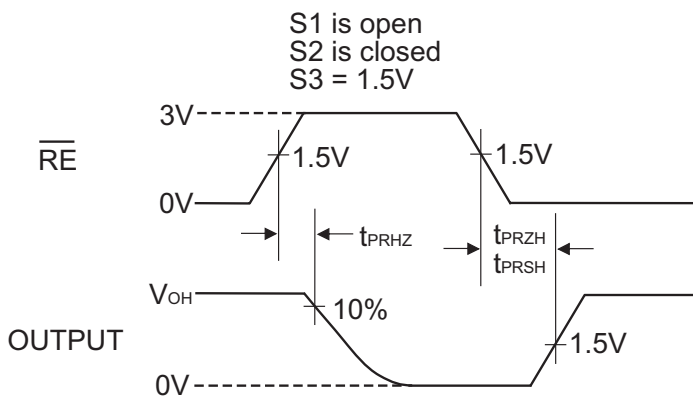

Figure 13. Receiver Enable and Disable Waveforms

Description

The SP3494 is a 3.3V low power half-duplex transceiver that meets the electrical specifications of the RS-485 and RS-422 serial protocols. This device is pin-to-pin compatible with the MaxLinear SP3481 and SP481 devices as well as popular industry standards such as the MAX3486 and the 75176. The SP3494 feature Maxlinear's BiCMOS process allowing low power operation without sacrificing performance. The SP3494 has a partially slew rate limited driver with a data transmission rate of 2.5Mbps.

Driver

The driver outputs of the SP3494 are differential outputs. The typical voltage output swing with no load will be 0 volts to V_{CC} . With worst case loading of 54Ω across the differential outputs, the driver can maintain greater than 1.5V voltage levels.

The SP3494 driver has an enable control line which is active HIGH. A logic HIGH on DE (pin 3) will enable the differential driver outputs. A logic LOW on the DE (pin 3) will force the driver outputs to high impedance (high-Z).

The SP3494 driver will operate up to 2.5Mbps. In addition to adhering to the 250mA I_{SC} maximum limit on the driver output, the driver output short-circuit protection will allow the device to withstand an infinite short circuit over the -7.0V to 12V common mode range without damage.

Receiver

The receiver has differential inputs with an input sensitivity of $\pm 200mV$. Input impedance of the receiver is typically $15k\Omega$ ($12k\Omega$ minimum). A wide common mode range of -7V to 12V allows for large ground potential differences between systems. The receiver is equipped with a fail-safe feature which guarantees that the receiver output will be in a high state when the input is left unconnected. The receiver of the SP3494 operate up to 2.5Mbps.

The receiver of the SP3494 has an enable control line which is active LOW. A logic LOW on \overline{RE} (pin 2) of the SP3494 will enable the differential receiver. A logic HIGH on \overline{RE} (pin 2) will disable the receiver.

The SP3494 is equipped with a shutdown mode. To enable the shutdown state, both the driver and receiver must be disabled simultaneously. A logic LOW on DE (pin 3) and a logic HIGH on \overline{RE} (pin 2) will put the SP3494 into shutdown. In shutdown, the supply current will drop to less than $10\mu A$.

INPUTS			LINE CONDITION	OUTPUTS	
\overline{RE}	DE	DI		B	A
X	1	1	No Fault	0	1
X	1	0	No Fault	1	0
X	0	X	X	Z	Z

Table 1. Transmit Function Truth Table

INPUTS		A - B	OUTPUTS
\overline{RE}	DE		R
0	0	0.2V	1
0	0	-0.2V	0
0	0	Inputs Open	1
1	0	X	Z

Table 2. Receive Function Truth Table

Mechanical Dimensions

NSOIC8

Top View

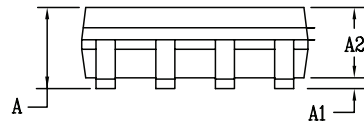

Side View

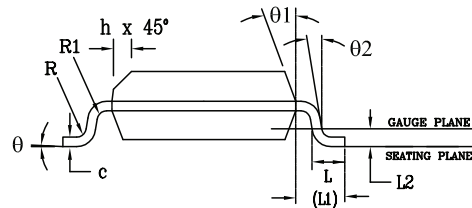

Front View

PACKAGE OUTLINE NSOIC .150" BODY JEDEC MS-012 VARIATION AA						
SYMBOLS	COMMON DIMENSIONS IN MM (Control Unit)			COMMON DIMENSIONS IN INCH (Reference Unit)		
	MIN	NOM	MAX	MIN	NOM	MAX
A	1.35	—	1.75	0.053	—	0.069
A1	0.10	—	0.25	0.004	—	0.010
A2	1.25	—	1.65	0.049	—	0.065
b	0.31	—	0.51	0.012	—	0.020
c	0.17	—	0.25	0.007	—	0.010
E	6.00 BSC			0.236 BSC		
E1	3.90 BSC			0.154 BSC		
e	1.27 BSC			0.050 BSC		
h	0.25	—	0.50	0.010	—	0.020
L	0.40	—	1.27	0.016	—	0.050
L1	1.04 REF			0.041 REF		
L2	0.25 BSC			0.010 BSC		
R	0.07	—	—	0.003	—	—
R1	0.07	—	—	0.003	—	—
q	0°	—	8°	0°	—	8°
q1	5°	—	15°	5°	—	15°
q2	0°	—	—	0°	—	—
D	4.90 BSC			0.193 BSC		
N	8					

Drawing No: POD-0000108

Revision: A

Ordering Information⁽¹⁾

Part Number	Operating Temperature Range	Lead-Free	Package	Packaging Method
SP3494CN-L/TR	0°C to 70°C	Yes ⁽²⁾	8-pin NSOIC	Reel
SP3494EN-L	-40°C to 85°C			Tube
SP3494EN-L/TR				Reel

NOTE:

1. Refer to www.exar.com/SP3494 for most up-to-date Ordering Information.
2. Visit www.exar.com for additional information on Environmental Rating.

Revision History

Revision	Date	Description
10/15/02	--	Legacy Sipex Datasheet
07/10/12	1.0.0	Convert to Exar Format. Update ordering information and add new Figure 8 - Driver Short Circuit Current Limit Test Circuit. Remove EOL device SP3493.
09/07/17	1.0.1	Update to MaxLinear logo. Remove GND from Differential Output Voltage min (page 2), correct part number (SP3485 Receiver, page 3). Added maximum junction temperature, package power dissipation and ESD rating. Update format and ordering information table.



Corporate Headquarters:
 5966 La Place Court
 Suite 100
 Carlsbad, CA 92008
 Tel.: +1 (760) 692-0711
 Fax: +1 (760) 444-8598
www.maxlinear.com

High Performance Analog:
 48720 Kato Road
 Fremont, CA 94538
 Tel.: +1 (510) 668-7000
 Fax: +1 (510) 668-7001
 Email: serialtechsupport@exar.com
www.exar.com

The content of this document is furnished for informational use only, is subject to change without notice, and should not be construed as a commitment by MaxLinear, Inc.. MaxLinear, Inc. assumes no responsibility or liability for any errors or inaccuracies that may appear in the informational content contained in this guide. Complying with all applicable copyright laws is the responsibility of the user. Without limiting the rights under copyright, no part of this document may be reproduced into, stored in, or introduced into a retrieval system, or transmitted in any form or by any means (electronic, mechanical, photocopying, recording, or otherwise), or for any purpose, without the express written permission of MaxLinear, Inc.

MaxLinear, Inc. does not recommend the use of any of its products in life support applications where the failure or malfunction of the product can reasonably be expected to cause failure of the life support system or to significantly affect its safety or effectiveness. Products are not authorized for use in such applications unless MaxLinear, Inc. receives, in writing, assurances to its satisfaction that: (a) the risk of injury or damage has been minimized; (b) the user assumes all such risks; (c) potential liability of MaxLinear, Inc. is adequately protected under the circumstances.

MaxLinear, Inc. may have patents, patent applications, trademarks, copyrights, or other intellectual property rights covering subject matter in this document. Except as expressly provided in any written license agreement from MaxLinear, Inc., the furnishing of this document does not give you any license to these patents, trademarks, copyrights, or other intellectual property.

Company and product names may be registered trademarks or trademarks of the respective owners with which they are associated.

© 2017 MaxLinear, Inc. All rights reserved

Mouser Electronics

Authorized Distributor

Click to View Pricing, Inventory, Delivery & Lifecycle Information:

Exar:

[SP3494EN-L](#) [SP3494CN-L](#) [SP3494CN-L/TR](#) [SP3494EN-L/TR](#)