

**DESIGNED & DIMENSIONED
IN MILLIMETERS
(INCHES FOR REFERENCE ONLY)**

HSEC8-1XXX-XX-XX-DV-X-XX

DO NOT
SCALE FROM
THIS PRINT

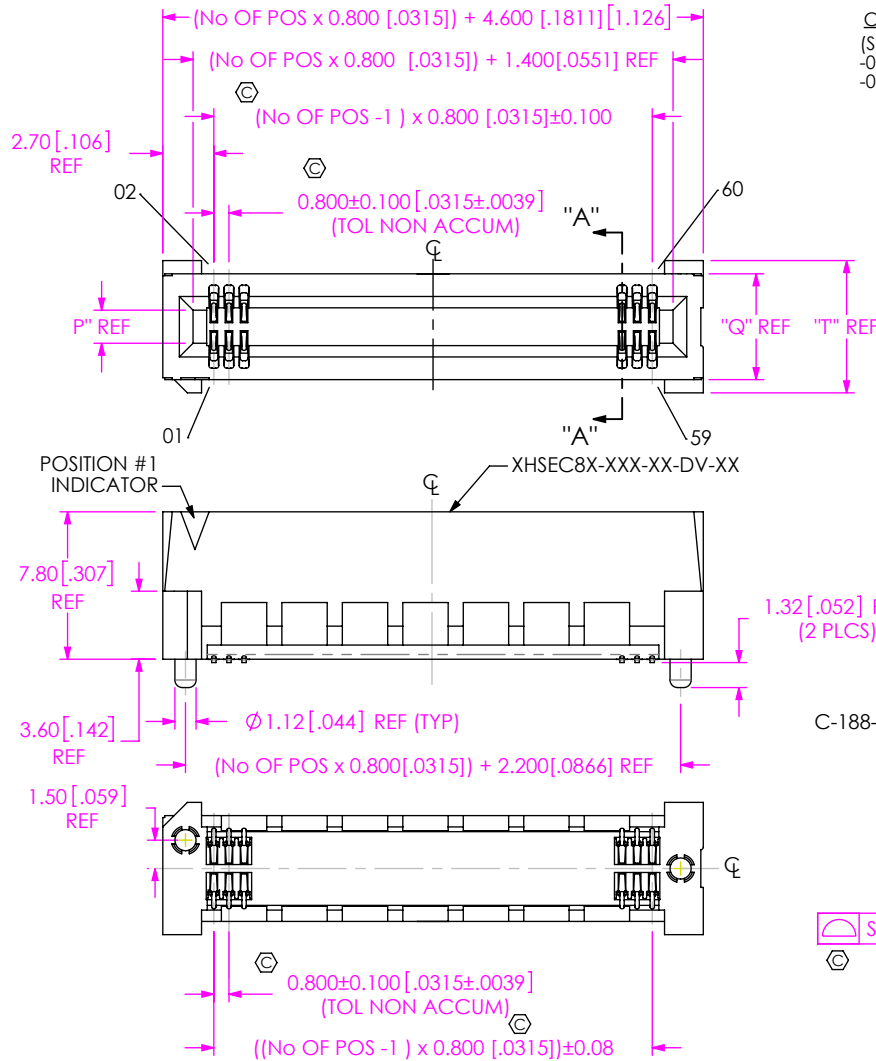

No OF POSITIONS (PER ROW)
-10, -20, -30 (SEE FIG 1)
-09, -13, -25, -37, -49, -40, -50, -60, -70, -80, -90, -100 (SEE FIG 2, SHT 2)

CARD THICKNESS
(SEE TABLE 9, SHT 3)
-01: 1.57 [.062] CARD
-03: 2.36 [.093] CARD
(10-100 POS, MULTIPLES OF 10 ONLY)
(-K & -TR ONLY FOR OPTION 2)
(USE RHSEC8-XXX-03-DV-XX)
(SEE NOTE 7 & 10)

PLATING SPECIFICATION
-SM: 30µ" SELECTIVE GOLD IN CONTACT AREA, MATTE TIN ON TAIL
-H: 30µ" HEAVY GOLD IN CONTACT AREA, 3µ" GOLD TAIL
-S: 30µ" SELECTIVE GOLD IN CONTACT AREA, MATTE TIN ON TAIL
-L: 10µ" LIGHT SELECTIVE GOLD IN CONTACT AREA, MATTE TIN ON TAIL

ROW SPECIFICATION
-DV: DOUBLE VERTICAL

OPTION 2
** -PE: PASS THROUGH (SHT 7, FIG 7) (10, 13, & 20 POS ONLY) (-A OPTION ONLY) (NOT AVAILABLE WITH ANY OTHER OPTION 2, EXCEPT -K AND/OR -TR)
** -BL: BOARD LOCK (SHT 5, FIG 5) (SEE NOTE 11) (-A OPTION ONLY)
** -GR: GUIDE RAILS (SHT 6, FIG 6) (10-60 POS, MULTIPLES OF 10 ONLY) (SEE NOTE 11) (-TR PACKAGING ONLY)
-WT: WELD TAB (SHT 7, FIG 8) (-A OPTION ONLY)
** -L: LATCHING (SHT 4, FIG 4) (13, 25, 37, & 49 POS ONLY) (SEE NOTE 11) (-A OPTION ONLY)
** -L2: ECDP LATCHING (SHT 8, FIG 9) (09, 13, 25, & 49 POS ONLY) (SEE NOTE 11) (-A OPTION ONLY)
-K: POLYIMIDE FILM PAD (SEE SHT 2, FIG 3) (09 THRU 70 POS ONLY) (LEAVE BLANK FOR TRAY)
OPTION 1
(LEAVE BLANK FOR NO ALIGNMENT PIN, USE XHSEC8-XXX-01-DV-LC, NOT AVAILABLE FOR CARD THICKNESS -02 & -03 SEE FIG 10, SHT 3)
-A: ALIGNMENT PIN (USE XHSEC8X-XXX-XX-DV-A)

** = AVAILABLE ONLY WITH -01 CARD THICKNESS
■ = AVAILABLE ONLY WITH END OPTIONS -BL, -WT, & -L2

NOTES:

1. © REPRESENTS A CRITICAL DIMENSION.
2. BURR ALLOWANCE: 0.04[.0015] MAX.
3. MINIMUM PUSHOUT FORCE: 2.2 NEWTONS.
4. ALL TAIL TO TAIL DIMENSIONS MEASURED TIP TO TIP.
5. ASSEMBLIES TO BE PACKAGED IN TRAYS, UNLESS -TR IS SPECIFIED.
6. NOTE DELETED.
7. MATING EDGE CARD THICKNESS TOLERANCE TO BE ±0.15 [.006] OF NOMINAL.
8. NOTE DELETED.
9. NOTE DELETED.
10. MATING CARD MUST HAVE LEAD-IN. SEE SAMTEC FOOTPRINT FOR SPECIFICATIONS.
11. L, L2, & BL IS NOT APPLICABLE FOR GUIDE RAIL TYPE USE. GR NOT APPLICABLE FOR L, L2, OR BL TYPE USE.
12. CORNER VOIDS AT VENDOR DISCRETION, AND MAY OR MAY NOT BE PRESENT.
13. MEASURE DIMENSION WITH LATCH IN LOCKED, PERPENDICULAR POSITION.
14. VOID WIDTH, LOCATION, AND FREQUENCY TO BE AT VENDORS DISCRETION.

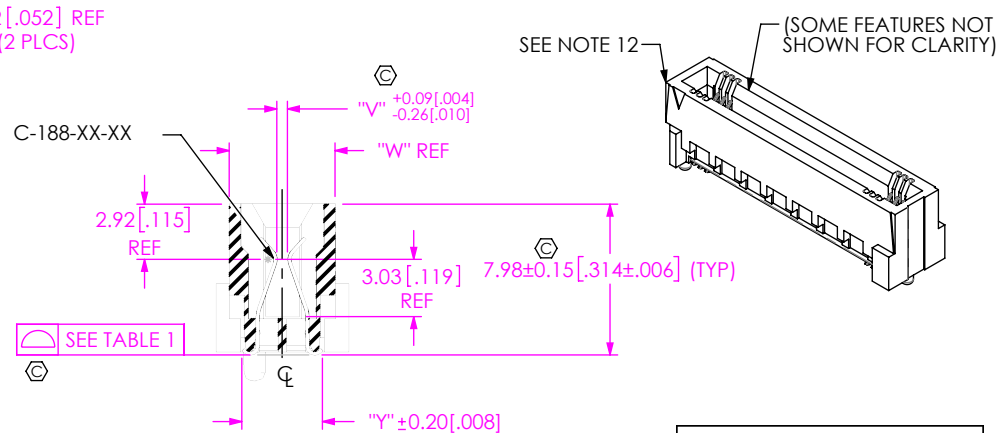

SECTION "A"- "A"

F:\DWG\MISC\MKTG\HSEC8-1XXX-XX-XX-DV-X-XX-MKT.SLDRAW

UNLESS OTHERWISE SPECIFIED, DIMENSIONS ARE IN MILLIMETERS.

TOLERANCES ARE:

DECIMALS ANGLES
.X: ± .3 [.01]
.XX: ± .13 [.005]
.XXX: ± .051 [.0020]

PROPRIETARY NOTE

THIS DOCUMENT CONTAINS CONFIDENTIAL AND PROPRIETARY INFORMATION AND ALL DESIGN, MANUFACTURING, REPRODUCTION, USE, PATENT RIGHTS AND SALES RIGHTS ARE EXPRESSLY RESERVED BY SAMTEC, INC. THIS DOCUMENT SHALL NOT BE DISCLOSED, IN WHOLE OR PART, TO ANY UNAUTHORIZED PERSON OR ENTITY NOR REPRODUCED, TRANSFERRED OR INCORPORATED IN ANY OTHER PROJECT IN ANY MANNER WITHOUT THE EXPRESS WRITTEN CONSENT OF SAMTEC, INC.

MATERIAL: DO NOT SCALE DRAWING SHEET SCALE: 2.5:1
INSULATOR: LCP
COLOR: -01 CARD THICKNESS BLACK, -02 & -03 CARD THICKNESS NATURAL
CONTACT: BeCu

DESCRIPTION:
0.8mm HIGH SPEED EDGE CARD ASSEMBLY

DWG. NO.
HSEC8-1XXX-XX-XX-DV-X-XX

BY: BRATCHER 01/24/03 SHEET 1 OF 8

TABLE 1	
No OF POS	COPLANARITY
-10 THRU -60	0.102 [.0040]
-70 THRU -100	0.127 [.0050]



520 PARK EAST BLVD, NEW ALBANY, IN 47150
PHONE: 812-944-6733 FAX: 812-948-5047
e-Mail: info@SAMTEC.com code: 55322

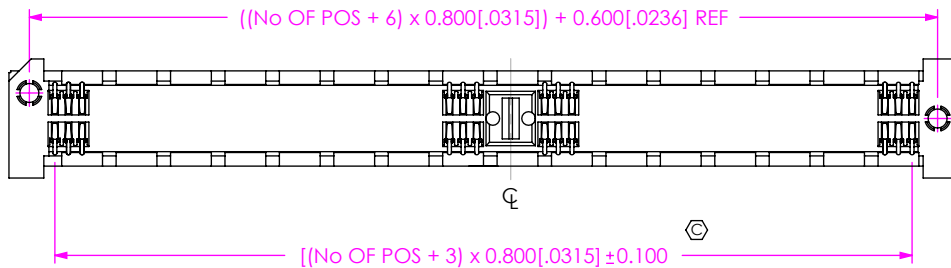
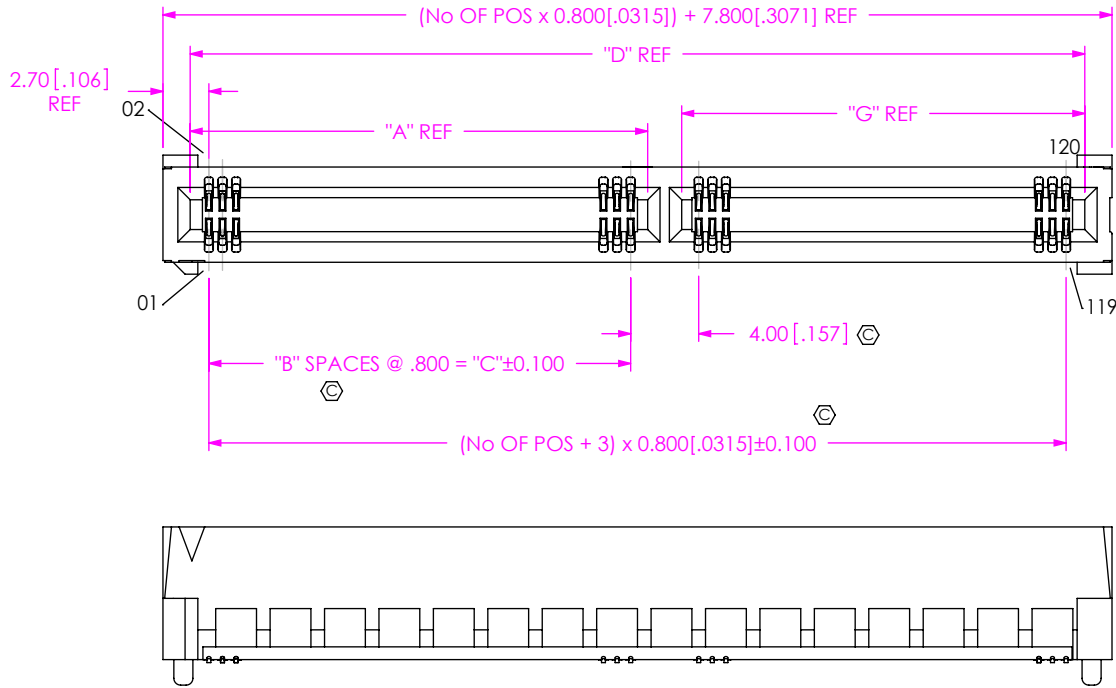

No OF POS	"A"	"B"	"C"	"D"	"G"
■**-09	4.50 [.177]	3	2.400 [.0945]	11.80 [.465]	5.30 [.209]
**13	6.10 [.240]	5	4.000 [.1575]	15.00 [.591]	6.90 [.272]
**25	6.10 [.240]	5	4.000 [.1575]	24.60 [.969]	16.50 [.650]
**37	18.10 [.713]	20	16.000 [.6299]	34.20 [1.346]	14.10 [.555]
-40	18.90 [.744]	21	16.800 [.6614]	36.60 [1.441]	15.70 [.618]
**49	22.90 [.902]	26	20.800 [.8189]	43.80 [1.724]	18.90 [.744]
-50	22.90 [.902]	26	20.800 [.8189]	44.60 [1.756]	19.70 [.776]
-60	26.90 [1.059]	31	24.800 [.9764]	52.60 [2.071]	23.70 [.933]
-70	26.90 [1.059]	31	24.800 [.9764]	60.60 [2.386]	31.70 [1.248]
-80	26.90 [1.059]	31	24.800 [.9764]	68.60 [2.701]	39.70 [1.563]
-90	26.90 [1.059]	31	24.800 [.9764]	76.60 [3.016]	47.70 [1.878]
-100	26.90 [1.059]	31	24.800 [.9764]	84.60 [3.331]	55.70 [2.193]

** = AVAILABLE ONLY WITH -01 CARD THICKNESS
 ■ = AVAILABLE ONLY WITH END OPTIONS -BL, -WT & -L2

FIG 2
 FOR POSITIONS ■**-09, **13, **25, **37, -40, **49, -50, -60, -70, -80, -90, -100
 HSEC8-160-01-XX-DV-A SHOWN
 (DIFFERENT AS SHOWN, OTHERWISE SAME AS FIG 1)
 (SOME FEATURES NOT SHOWN FOR CLARITY)
 (** = AVAILABLE ONLY WITH -01 CARD THICKNESS)

FIG 3
 -K OPTION
 (SOME FEATURES NOT SHOWN FOR CLARITY) 8.11 [.319]

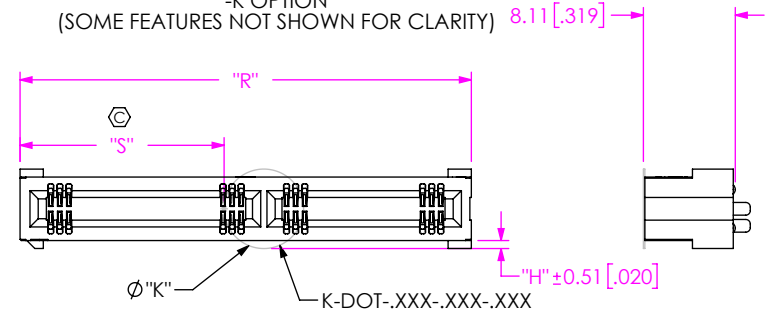

OPTION 2	No OF POS	"R"	"S"
NONE	-10 THRU -30	(No OF POS x 0.800[.0315]) + 4.600[.1811] REF	((("R" - "K") / 2) + /-0.51 [.020])
	-13, -25, -37, -40 THRU -100	(No OF POS x 0.800[.0315]) + 7.800[.3071] REF	
-WT	-10 THRU -30	(No OF POS x 0.800[.0315]) + 9.200[.3622] REF	
	-09, -13, -25, -37, -40 THRU -100	(No OF POS x 0.800[.0315]) + 12.400[.4882] REF	
**L	-13, -25, -37, & -49	(No OF POS x 0.800[.0315]) + 18.400[.7244] REF	
	-10 THRU -30	(No OF POS x 0.800[.0315]) + 15.850[.6240] REF	
**BL	-09, -13, -25, -37, -40 THRU -100	(No OF POS x 0.800[.0315]) + 19.050[.7500] REF	
	-10, -13, & -20	(No OF POS x 0.800[.0315]) + 7.000 [.2756] REF	
**PE	-10, -20, -30	(No OF POS x 0.800[.0315]) + 4.600[.1811] REF	
	-40, -50, -60	(No OF POS x 0.800[.0315]) + 7.800[.3071] REF	
**L2	-09, -13, -25, -49	(No OF POS x 0.800[.0315]) + 13.660[.5378] REF	

** = AVAILABLE ONLY WITH -01 CARD THICKNESS

CARD THICKNESS	K-DOT-XXX-XXX-XXX	"K"	"U"	"H"
-01	K-DOT-.276-.375-.005	7.01 [.276]	2.61 [.103]	0.705 [.0278]
-03	K-DOT-.246-.375-.005	6.25 [.246]	3.40 [.134]	0.070 [.0027]

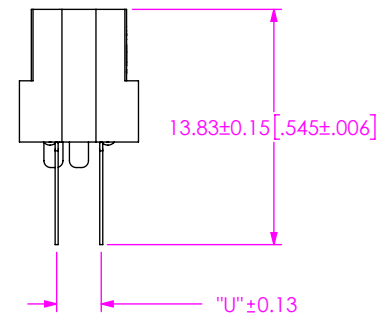

IN-PROCESS

PROPRIETARY NOTE
 THIS DOCUMENT CONTAINS CONFIDENTIAL AND PROPRIETARY INFORMATION AND ALL DESIGN, MANUFACTURING, REPRODUCTION, USE, PATENT RIGHTS AND SALES RIGHTS ARE EXPRESSLY RESERVED BY SAMTEC, INC. THIS DOCUMENT SHALL NOT BE DISCLOSED, IN WHOLE OR PART, TO ANY UNAUTHORIZED PERSON OR ENTITY NOR REPRODUCED, TRANSFERRED OR INCORPORATED IN ANY OTHER PROJECT IN ANY MANNER WITHOUT THE EXPRESS WRITTEN CONSENT OF SAMTEC, INC.



520 PARK EAST BLVD, NEW ALBANY, IN 47150
 PHONE: 812-944-6733 FAX: 812-948-5047
 e-Mail: info@SAMTEC.com code: 55322

DO NOT SCALE DRAWING

SHEET SCALE: 2.25:1

DESCRIPTION:
 0.8mm HIGH SPEED EDGE CARD ASSEMBLY

DWG. NO.
HSEC8-1XXX-XX-XX-DV-X-XX

BY: BRATCHER 01/24/03 SHEET 2 OF 8

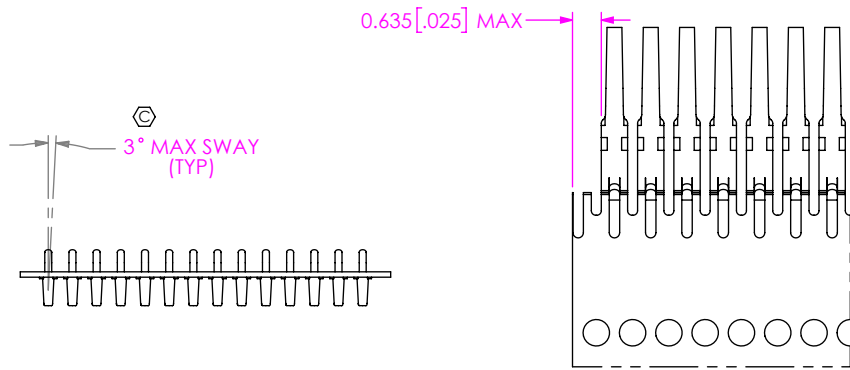

C-188-XXX-X IN-PROCESS VIEW

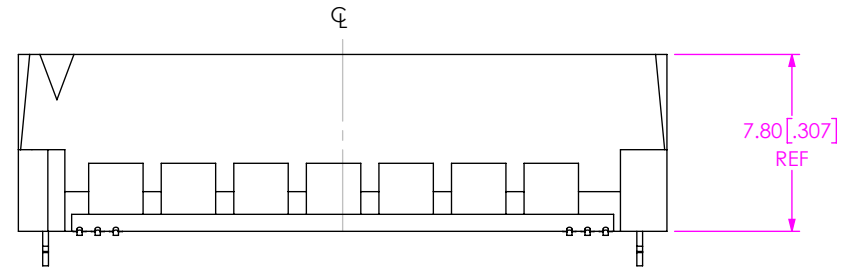

FIG 10
 **NON-ALIGNMENT PIN OPTION
 HSEC8-130-01-XX-DV SHOWN
 (DIFFERENT AS SHOWN, OTHERWISE SAME AS FIG 1)
 (** = AVAILABLE ONLY WITH -01 CARD THICKNESS)
 (SOME FEATURES NOT SHOWN FOR CLARITY)

TABLE 9

CARD	OPTION 2	BODY	CONTACT	"P"	"Q"	"T"	"V"	"W"	"Y"
-01	-L	RHSEC8-XXX-01-DV-A-L	C-188-02-X	1.75 [.069]	5.60 [.220]	7.00 [.276]	0.56 [.022]	5.60 [.220]	4.26 [.168]
	-L2	RHSEC8-XXX-01-DV-A-L2	C-188-02-X					5.60 [.220]	
	-BL	RHSEC8-XXX-01-DV-A-BL	C-188-02-X					5.60 [.220]	
	-GR	RHSEC8-XXX-01-DV-XX-GR	C-188-02-X					5.60 [.220]	
	-PE	HSEC8-XXX-01-DV-A-PE	C-188-01-X					4.60 [.180]	
	-WT	RHSEC8-XXX-01-DV-A-WT	C-188-02-X					5.60 [.220]	
-03	NONE	RHSEC8-XXX-01-DV-XX	C-188-02-X	2.54 [.100]	6.39 [.252]	7.79 [.307]	1.35 [.053]	5.60 [.220]	5.05 [.199]
	NONE	RHSEC8-XXX-03-DV-A	C-188-02-X					6.39 [.252]	
	-WT	RHSEC8-XXX-03-DV-A-WT	C-188-02-X					6.39 [.252]	

PROPRIETARY NOTE
 THIS DOCUMENT CONTAINS CONFIDENTIAL AND PROPRIETARY INFORMATION AND ALL DESIGN, MANUFACTURING, REPRODUCTION, USE, PATENT RIGHTS AND SALES RIGHTS ARE EXPRESSLY RESERVED BY SAMTEC, INC. THIS DOCUMENT SHALL NOT BE DISCLOSED, IN WHOLE OR IN PART, TO ANY UNAUTHORIZED PERSON OR ENTITY NOR REPRODUCED, TRANSFERRED OR INCORPORATED IN ANY OTHER PROJECT IN ANY MANNER WITHOUT THE EXPRESS WRITTEN CONSENT OF SAMTEC, INC.

DO NOT SCALE DRAWING

SHEET SCALE: 2:1



520 PARK EAST BLVD, NEW ALBANY, IN 47150
 PHONE: 812-944-6733 FAX: 812-948-5047
 e-Mail info@SAMTEC.com code 55322

DESCRIPTION:
 0.8mm HIGH SPEED EDGE CARD ASSEMBLY

DWG. NO.
 HSEC8-1XXX-XX-XX-DV-X-XX

BY: BRATCHER 01/24/03 SHEET 3 OF 8

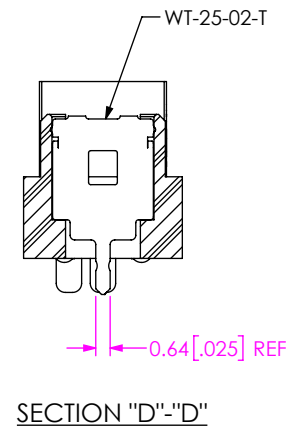
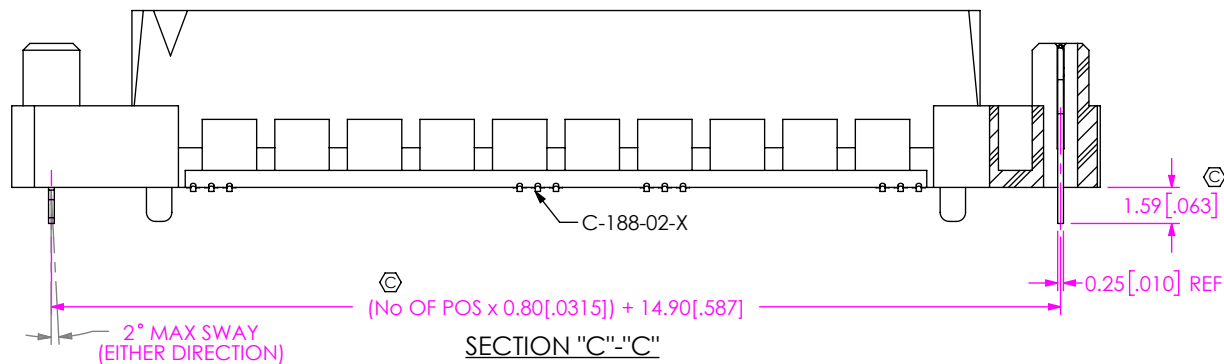
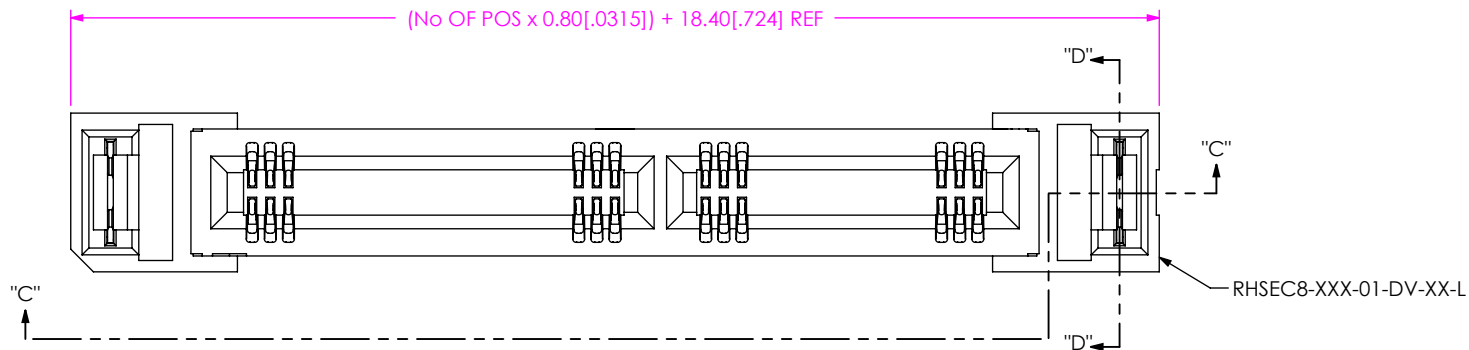

FIG 4
 **L: LATCHING OPTION
 HSEC8-137-01-XX-DV-A-L SHOWN
 AVAILABLE IN -13, -25, -37 & -49 POSITIONS ONLY
 (NOT AVAILABLE FOR -GR TYPE USE)
 (DIFFERENT AS SHOWN, OTHERWISE SAME AS FIG 2)
 (SOME FEATURES NOT SHOWN FOR CLARITY)
 (** = AVAILABLE ONLY WITH -01 CARD THICKNESS)

PROPRIETARY NOTE
 THIS DOCUMENT CONTAINS CONFIDENTIAL AND PROPRIETARY INFORMATION AND ALL DESIGN, MANUFACTURING, REPRODUCTION, USE, PATENT RIGHTS AND SALES RIGHTS ARE EXPRESSLY RESERVED BY SAMTEC, INC. THIS DOCUMENT SHALL NOT BE DISCLOSED, IN WHOLE OR PART, TO ANY UNAUTHORIZED PERSON OR ENTITY NOR REPRODUCED, TRANSFERRED OR INCORPORATED IN ANY OTHER PROJECT IN ANY MANNER WITHOUT THE EXPRESS WRITTEN CONSENT OF SAMTEC, INC.

DO NOT SCALE DRAWING
 SHEET SCALE: 3:1



520 PARK EAST BLVD, NEW ALBANY, IN 47150
 PHONE: 812-944-6733 FAX: 812-948-5047
 e-Mail: info@SAMTEC.com code: 55322

DESCRIPTION:
 0.8mm HIGH SPEED EDGE CARD ASSEMBLY

DWG. NO.
HSEC8-1XXX-XX-XX-DV-X-XX

BY: BRATCHER 01/24/03 SHEET 4 OF 8

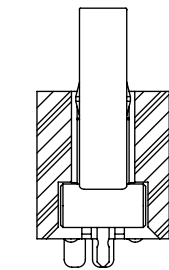
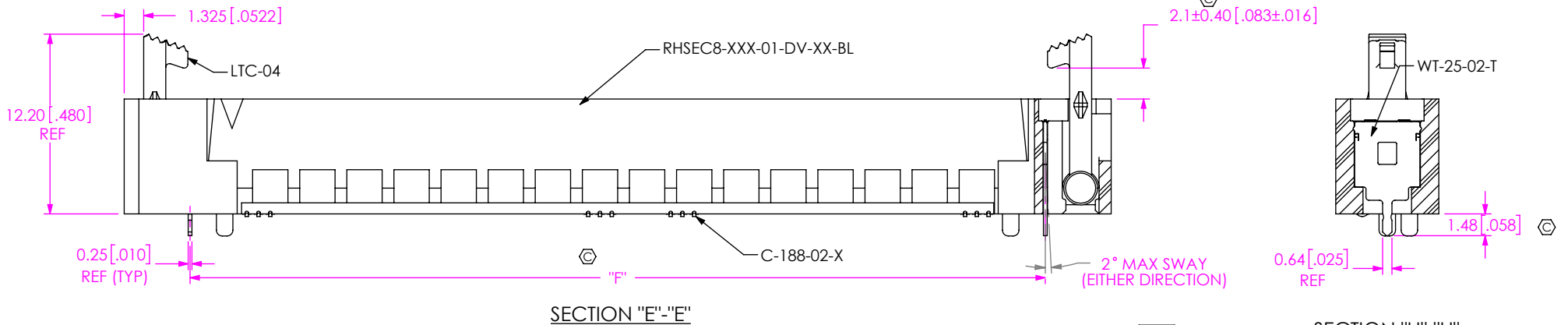
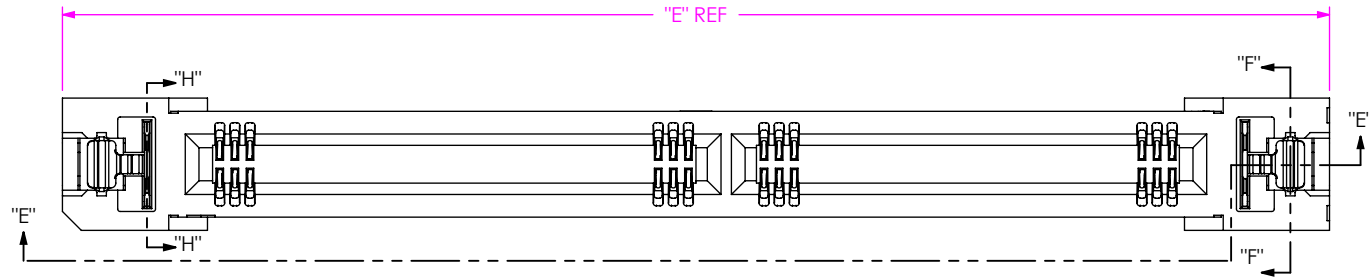
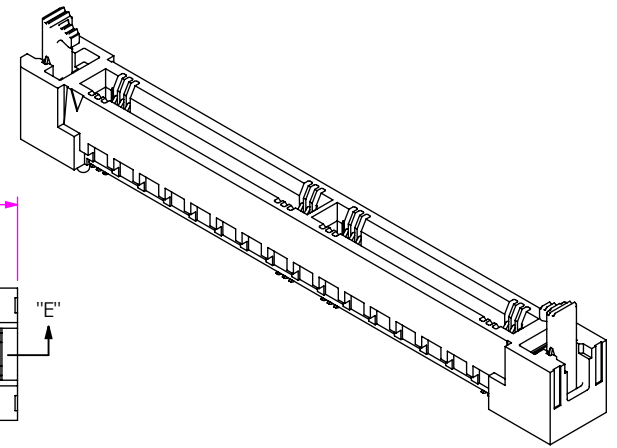

SECTION "F"-"F"

SECTION "E"-"E"

SECTION "H"-"H"

TABLE 4		
No OF POSITIONS	"E"	"F"
-09	26.25 [1.033]	17.30 [0.681]
-10	23.85 [0.939]	14.90 [0.587]
-13	29.45 [1.159]	20.50 [0.807]
-20	31.85 [1.254]	22.90 [0.902]
-25	39.05 [1.537]	30.10 [1.185]
-30	39.85 [1.569]	30.90 [1.217]
-37	48.65 [1.915]	39.70 [1.563]
-40	51.05 [2.010]	42.10 [1.657]
-49	58.25 [2.293]	49.30 [1.941]
-50	59.05 [2.325]	50.10 [1.972]
-60	67.05 [2.640]	58.10 [2.287]
-70	75.05 [2.955]	66.10 [2.602]
-80	83.05 [3.270]	74.10 [2.917]
-90	91.05 [3.585]	82.10 [3.232]
-100	99.05 [3.900]	90.10 [3.547]

FIG 5

** -BL: BOARD LOCK OPTION
HSEC8-160-01-XX-DV-A-BL SHOWN
(NOT AVAILABLE FOR -GR TYPE USE)
(FOR -09, -13, -25, 37, -40, -49, -50, -60, -70, -80, -90 & -100
POSITIONS DIFFERENT AS SHOWN, OTHERWISE SAME AS FIG 2)
(FOR -10, -20 & -30 POSITIONS DIFFERENT AS SHOWN,
OTHERWISE SAME AS FIG 1)
(** = AVAILABLE ONLY WITH -01 CARD THICKNESS)
(SOME FEATURES NOT SHOWN FOR CLARITY)
(AVAILABLE IN ALL POSITIONS)

PROPRIETARY NOTE
THIS DOCUMENT CONTAINS CONFIDENTIAL AND
PROPRIETARY INFORMATION AND ALL DESIGN,
MANUFACTURING, REPRODUCTION, USE, PATENT RIGHTS
AND SALES RIGHTS ARE EXPRESSLY RESERVED BY SAMTEC,
INC. THIS DOCUMENT SHALL NOT BE DISCLOSED, IN WHOLE
OR PART, TO ANY UNAUTHORIZED PERSON OR ENTITY NOR
REPRODUCED, TRANSFERRED OR INCORPORATED IN ANY
OTHER PROJECT IN ANY MANNER WITHOUT THE EXPRESS
WRITTEN CONSENT OF SAMTEC, INC.

DO NOT SCALE DRAWING

SHEET SCALE: 2.5:1



520 PARK EAST BLVD, NEW ALBANY, IN 47150
PHONE: 812-944-6733 FAX: 812-948-5047
e-Mail: info@SAMTEC.com code: 55322

DESCRIPTION:
0.8mm HIGH SPEED EDGE CARD ASSEMBLY

DWG. NO.
HSEC8-1XXX-XX-XX-DV-X-XX

BY: BRATCHER 01/24/03 SHEET 5 OF 8

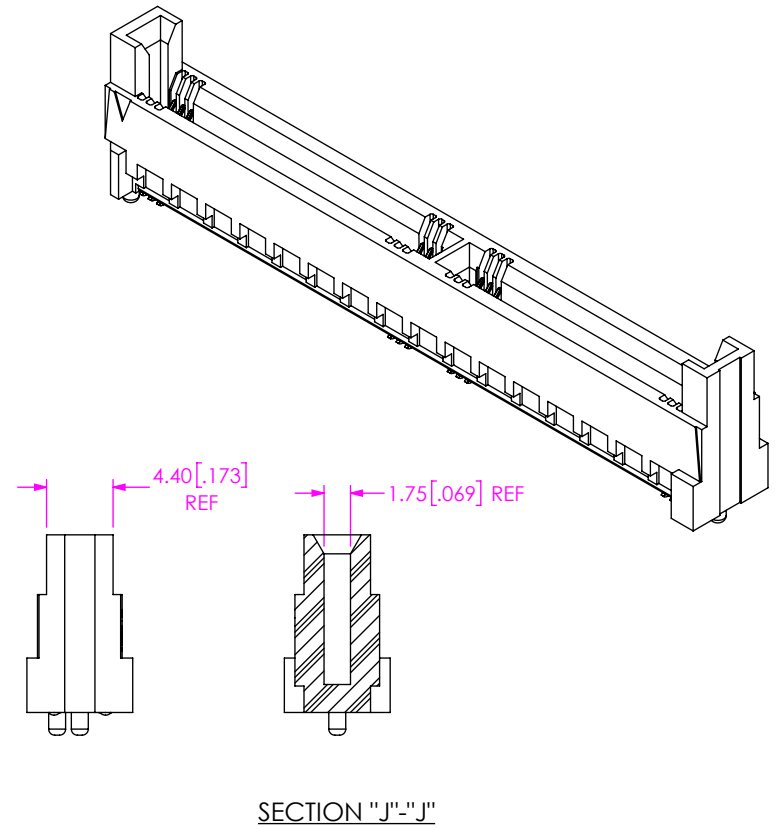
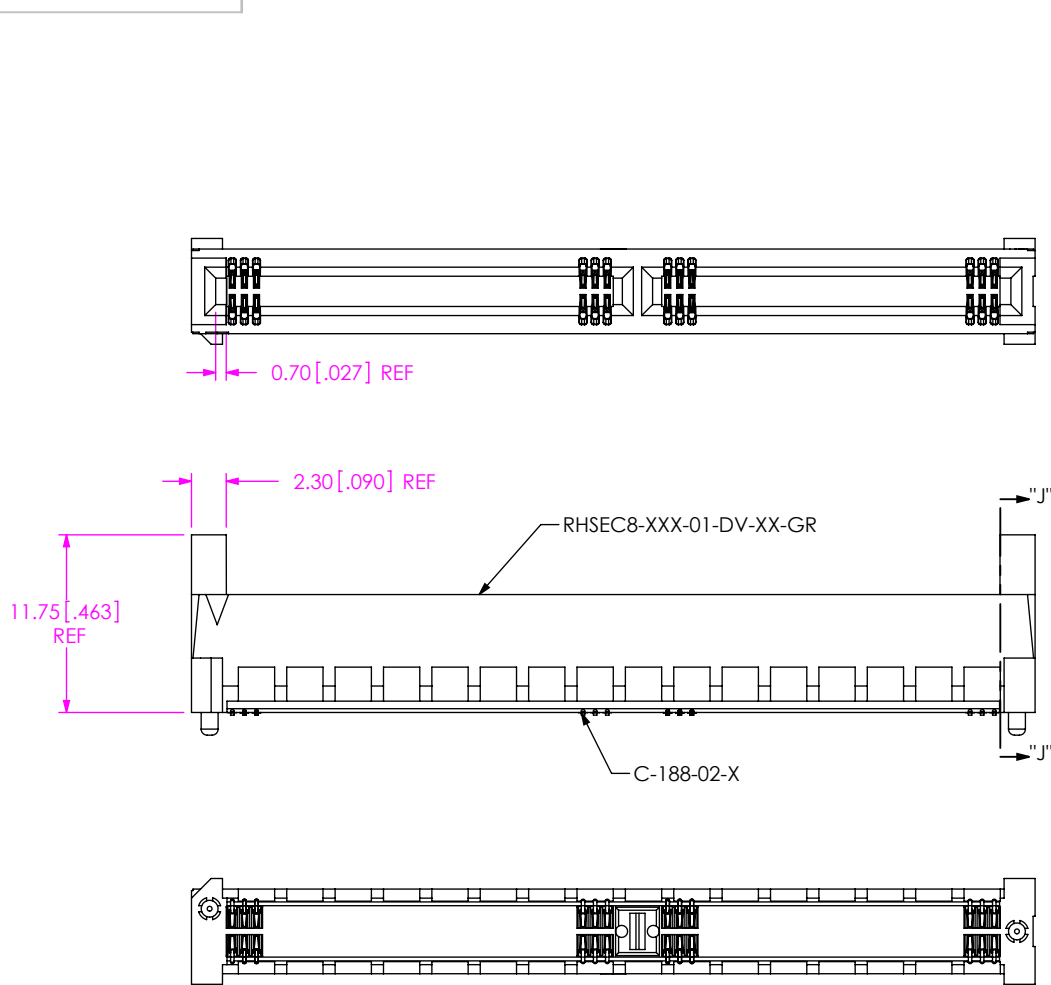

FIG 6
 **GR: GUIDE RAILS OPTION
 HSEC8-160-01-XX-DV-A-GR SHOWN
 AVAILABLE IN -10, -20, -30, -40, -50, & -60 POSITIONS ONLY
 (NOT AVAILABLE FOR -L; -BL TYPE USE)
 (DIFFERENT AS SHOWN, OTHERWISE SAME AS FIG 2)
 (SOME FEATURES NOT SHOWN FOR CLARITY)
 (** = AVAILABLE ONLY WITH -01 CARD THICKNESS)

PROPRIETARY NOTE
 THIS DOCUMENT CONTAINS CONFIDENTIAL AND PROPRIETARY INFORMATION AND ALL DESIGN, MANUFACTURING, REPRODUCTION, USE, PATENT RIGHTS AND SALES RIGHTS ARE EXPRESSLY RESERVED BY SAMTEC, INC. THIS DOCUMENT SHALL NOT BE DISCLOSED, IN WHOLE OR PART, TO ANY UNAUTHORIZED PERSON OR ENTITY NOR REPRODUCED, TRANSFERRED OR INCORPORATED IN ANY OTHER PROJECT IN ANY MANNER WITHOUT THE EXPRESS WRITTEN CONSENT OF SAMTEC, INC.

DO NOT SCALE DRAWING
 SHEET SCALE: 2:1



520 PARK EAST BLVD, NEW ALBANY, IN 47150
 PHONE: 812-944-6733 FAX: 812-948-5047
 e-Mail: info@SAMTEC.com code: 55322

DESCRIPTION:
 0.8mm HIGH SPEED EDGE CARD ASSEMBLY
 DWG. NO.
HSEC8-1XXX-XX-XX-DV-X-XX
 BY: BRATCHER 01/24/03 SHEET 6 OF 8

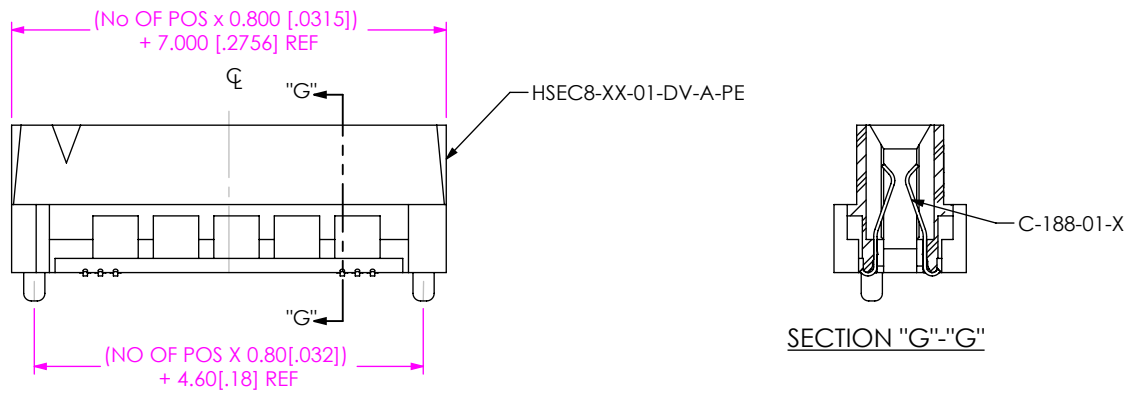

FIG 7
 **-PE: PASS THROUGH OPTION
 HSEC8-120-01-XX-DV-A-PE SHOWN
 AVAILABLE IN -10, *-13 & -20 POSITIONS ONLY
 (DIFFERENT AS SHOWN, OTHERWISE SAME AS FIG 1)
 (SOME FEATURES NOT SHOWN FOR CLARITY)
 ** = AVAILABLE ONLY WITH -01 CARD THICKNESS
 *-13 IS A ONE BANK PART

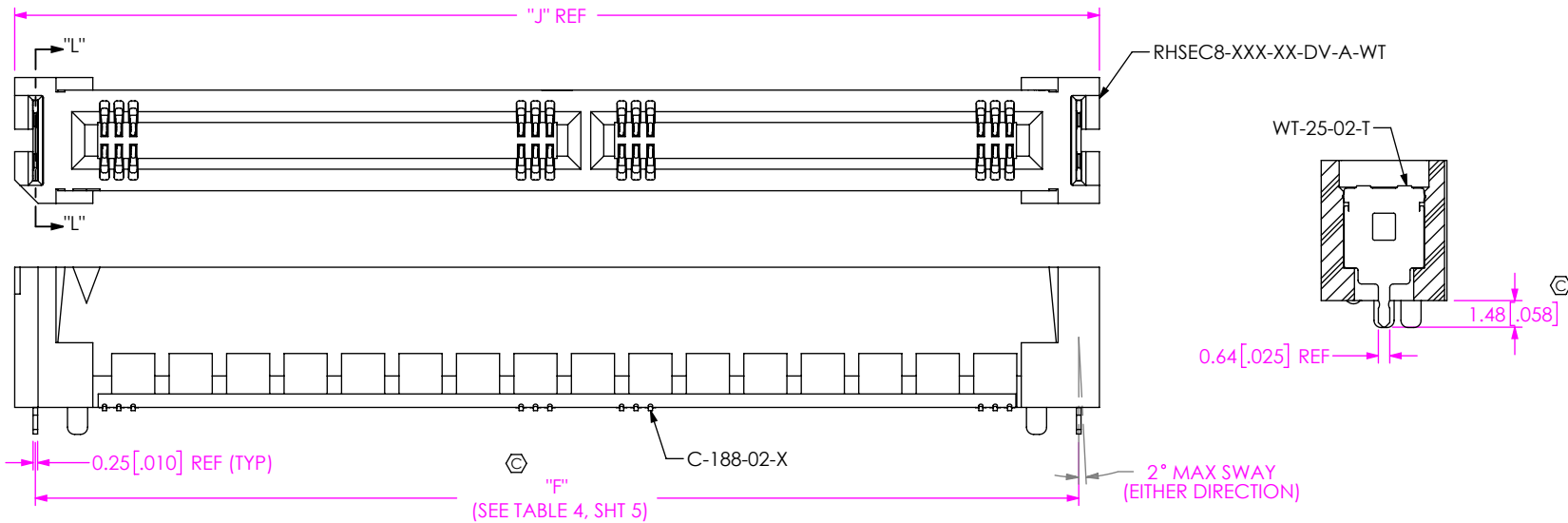

FIG 8
 -WT: WELD TAB OPTION
 HSEC8-160-01-XX-DV-A-WT SHOWN
 AVAILABLE IN ALL POSITIONS
 (-A OPTION REQUIRED)
 (DIFFERENT AS SHOWN, OTHERWISE SAME AS FIG 2)
 (SOME FEATURES NOT SHOWN FOR CLARITY)

TABLE 7

No OF POSITIONS	"J"
-09	19.60 [0.772]
-10	17.20 [0.677]
-13	22.80 [0.898]
-20	25.20 [0.992]
-25	32.40 [1.276]
-30	33.20 [1.307]
-37	42.00 [1.654]
-40	44.40 [1.748]
-49	51.60 [2.031]
-50	52.40 [2.063]
-60	60.40 [2.378]
-70	68.40 [2.693]
-80	76.40 [3.008]
-90	84.40 [3.323]
-100	92.40 [3.638]

PROPRIETARY NOTE
 THIS DOCUMENT CONTAINS CONFIDENTIAL AND PROPRIETARY INFORMATION AND ALL DESIGN, MANUFACTURING, REPRODUCTION, USE, PATENT RIGHTS AND SALES RIGHTS ARE EXPRESSLY RESERVED BY SAMTEC, INC. THIS DOCUMENT SHALL NOT BE DISCLOSED, IN WHOLE OR PART, TO ANY UNAUTHORIZED PERSON OR ENTITY NOR REPRODUCED, TRANSFERRED OR INCORPORATED IN ANY OTHER PROJECT IN ANY MANNER WITHOUT THE EXPRESS WRITTEN CONSENT OF SAMTEC, INC.

DO NOT SCALE DRAWING
 SHEET SCALE: 2.5:1



520 PARK EAST BLVD, NEW ALBANY, IN 47150
 PHONE: 812-944-6733 FAX: 812-948-5047
 e-Mail info@SAMTEC.com code 55322

DESCRIPTION:
 0.8mm HIGH SPEED EDGE CARD ASSEMBLY

DWG. NO.
HSEC8-1XXX-XX-XX-DV-X-XX

BY: BRATCHER 01/24/03 SHEET 7 OF 8

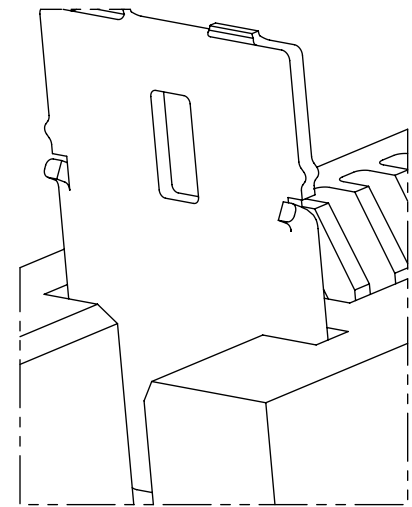
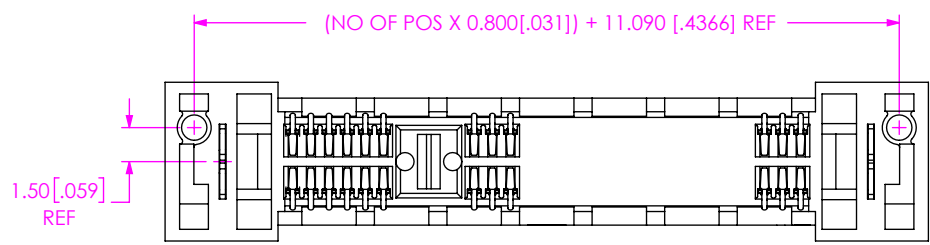
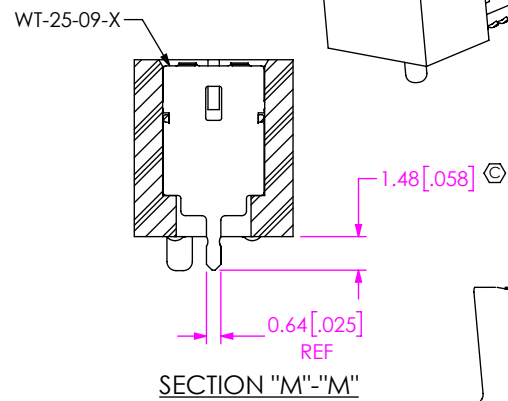
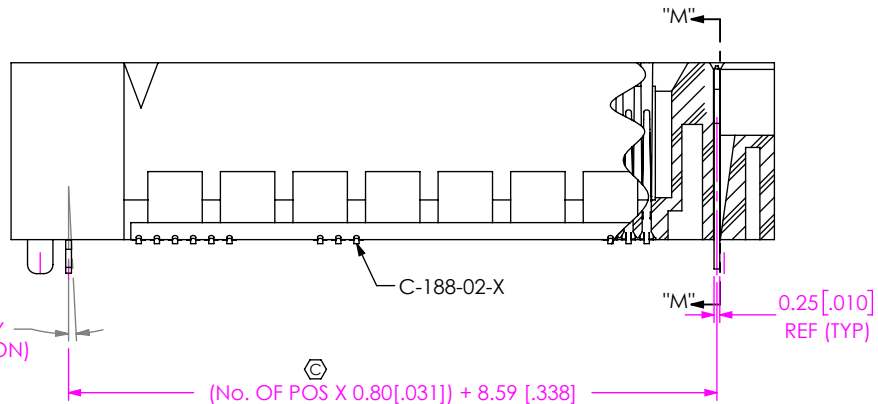
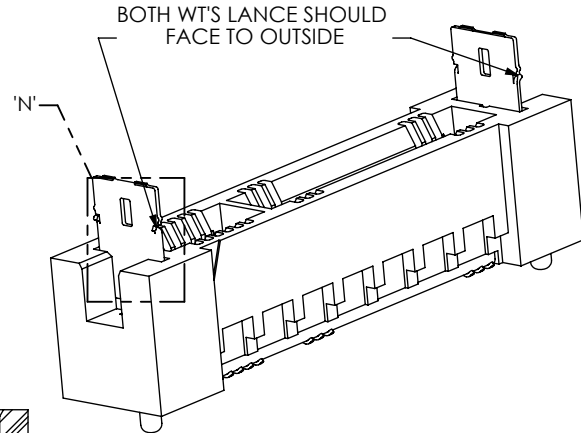
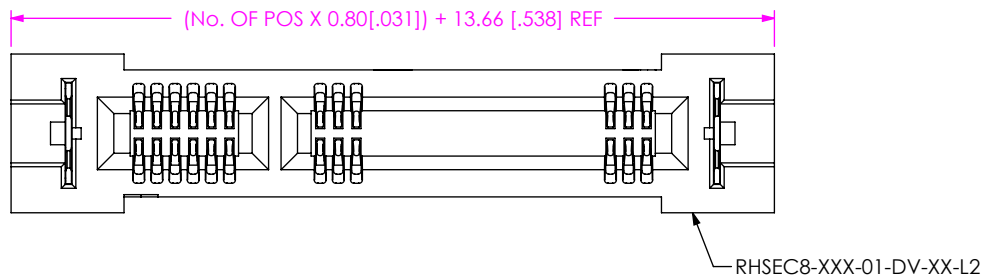

SCALE 10 : 1

FIG 9
 **-L2: ECDP LATCHING OPTION
 HSEC8-125-01-XX-DV-A-L2 SHOWN
 (AVAILABLE IN 9, 13, 25, & 49 POS ONLY)
 (NOT AVAILABLE FOR -GR TYPE USE)
 (DIFFERENT AS SHOWN, OTHERWISE SAME AS FIG 2)
 (SOME FEATURES NOT SHOWN FOR CLARITY)
 (** = AVAILABLE ONLY WITH -01 CARD THICKNESS)

F:\DWG\MISC\MKTG\HSEC8-1XXX-XX-XX-DV-X-XX-MKT.SLDDRW

PROPRIETARY NOTE
 THIS DOCUMENT CONTAINS CONFIDENTIAL AND PROPRIETARY INFORMATION AND ALL DESIGN, MANUFACTURING, REPRODUCTION, USE, PATENT RIGHTS AND SALES RIGHTS ARE EXPRESSLY RESERVED BY SAMTEC, INC. THIS DOCUMENT SHALL NOT BE DISCLOSED, IN WHOLE OR PART, TO ANY UNAUTHORIZED PERSON OR ENTITY NOR REPRODUCED, TRANSFERRED OR INCORPORATED IN ANY OTHER PROJECT IN ANY MANNER WITHOUT THE EXPRESS WRITTEN CONSENT OF SAMTEC, INC.

DO NOT SCALE DRAWING
 SHEET SCALE: 3:1



520 PARK EAST BLVD, NEW ALBANY, IN 47150
 PHONE: 812-944-6733 FAX: 812-948-5047
 e-Mail info@SAMTEC.com code 55322

DESCRIPTION:
 0.8mm HIGH SPEED EDGE CARD ASSEMBLY
 DWG. NO.
HSEC8-1XXX-XX-XX-DV-X-XX
 BY: BRATCHER 01/24/03 SHEET 8 OF 8