

DO NOT SCALE FROM THIS PRINT

QSH-XXX-XX-X-D-DP-XXX

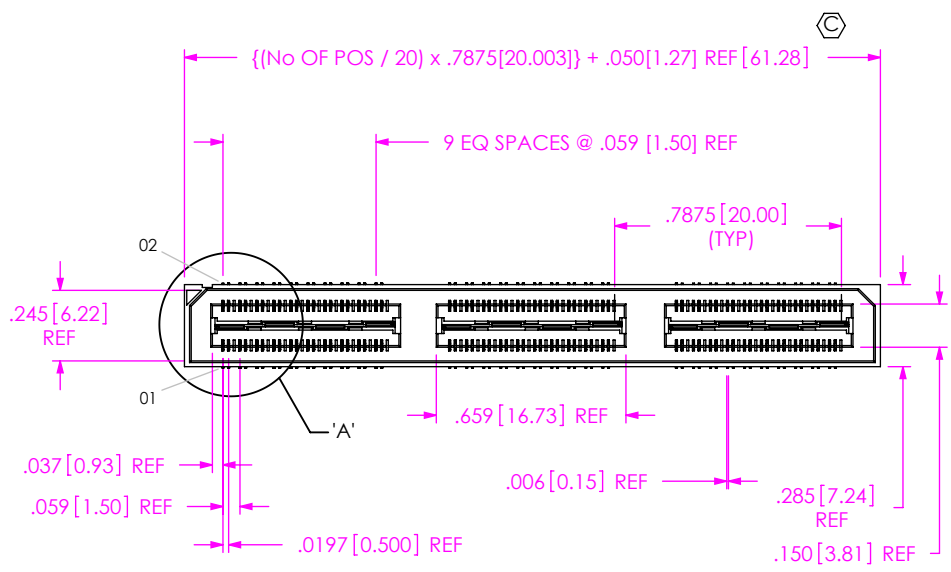

**No OF POSITIONS**  
 -020, -040, -060, \*\*080, \*\*100 (PER ROW)  
**LEAD STYLE**  
 -01: .1280 [3.251]

**PLATING SPECIFICATION**  
 (SEE NOTE 11)  
 -F: 3u" FLASH SELECTIVE IN CONTACT AREA, MATTE TIN ON TAIL (USE T-1G2-01-F) (SEE NOTE 9)  
 -L: 10u" LIGHT SELECTIVE GOLD IN CONTACT AREA, MATTE TIN ON TAIL (USE T-1G2-01-L) (SEE NOTE 9)  
 -H: 30u" HEAVY GOLD IN CONTACT AREA, 3u" GOLD ON TAIL (USE T-1G2-01-G)  
 -C: 50u" ELECTRO-POLISHED SELECTIVE GOLD IN CONTACT AREA, MATTE TIN ON TAIL (USE T-1G2-01-L) (SEE NOTE 9)

**C-126-01-X CAN BE SUBBED FOR C-126-21-X**  
**\*\* = SEE NOTE 10**

**OPTION**  
 -A: ALIGNMENT PINS (USE QSH-30-01-D-XX-A, SEE FIG 2)  
 -GP: GUIDE POSTS (USE QSH-30-01-D-XX-GP, SEE FIG 4)  
 -LC: LOCKING CLIPS (SEE NOTE 12) (USE LC-08-TM-01, SEE FIG 1)  
 -K: POLYIMIDE FILM PAD (USE K-DOT-.325-.450-.005, SEE FIG. 3)  
 -TR: TAPE & REEL (60 POS MAX)  
 -TY: TRAY PACKAGING (NOT AVAILABLE WITH -TR)  
 -FL: FRICTION LOCKS (SEE FIG 5, SHEET 3) (NOT AVAILABLE WITH -GP)  
 -RT1: RETENTION (MUST USE -A OPTION) (USE QSH-30-01-D-XX-A-RT1 & SUB-SC-05-01-FF) (SEE FIG 6, SHEET 3) (NOT AVAILABLE WITH -LC, -GP, OR -FL) (NOT AVAILABLE WITH -080 & -100 POS)  
 -L: LATCHING (SEE FIG 7, SHEET 4) (USE QSH-30-01-D-XX-A-L) (NOT AVAILABLE WITH -LC, -GP, -FL, OR -RT1)

**DIFFERENTIAL PAIRS**  
 -D: DOUBLE (USE QSH-30-01-D-XX)

**ROW SPECIFICATION**  
 -D: DOUBLE (USE QSH-30-01-D-XX)

No OF BANKS

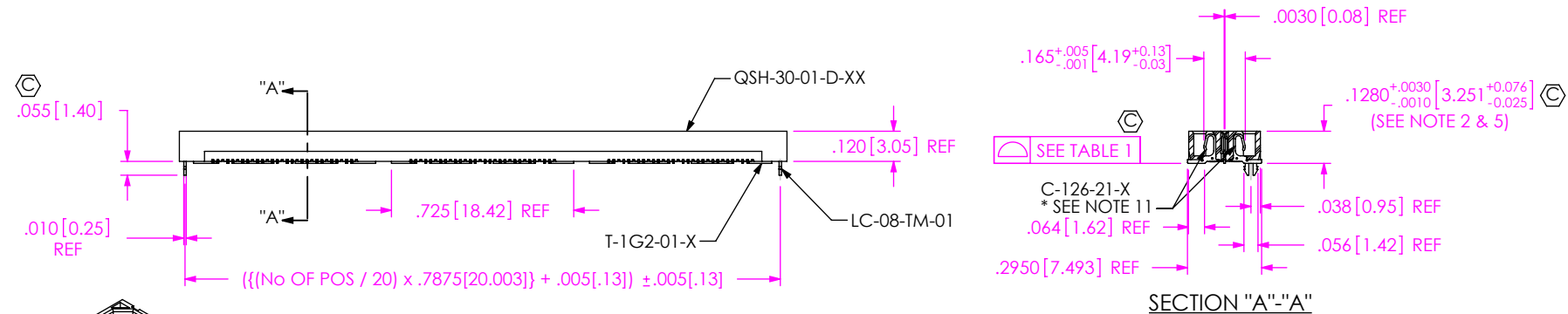

FIG 1  
 -LC: LOCKING CLIP OPTION SHOWN

**TABLE 1**

No OF POS	COPLANARITY (INCLUDES GROUND PLANE)
-020 THRU -060	.0040 [102]
-080 THRU -100	.0060 [152]

**NOTES:**

- ⊙ REPRESENTS A CRITICAL DIMENSION.
- MAXIMUM VARIANCE: .002 [0.05]
- MAXIMUM BURR ALLOWANCE: .0015 [0.038]
- MINIMUM PUSHOUT FORCE: 4 OZ
- DIMENSION APPLIES TO GROUND PLANE AND CONTACT.
- MINIMUM GROUND PLANE RETENTION: 8 OZ
- L PLATING CAN BE SUBSTITUTED FOR -F PLATING.
- SUB-SC-05-01-XX RETENTION TO BE 1.0 LBF IN BODY.
- MAY SUB C-126-01-X FOR C-126-21-X.
- FOR NEW APPLICATIONS REQUIRING THESE POSITIONS PLEASE CONTACT SAMTEC INTERCONNECT PROCESSING GROUP.
- FOR -80, -100 POSITIONS USE C-269-11-X. DO NOT SUB C-126.
- DUE TO THE HIGH AMOUNT OF INSERTION FORCE NEEDED, THE -LC OPTION IS NOT COMPATIBLE WITH AUTO PLACEMENT. SAMTEC RECOMMENDS MANUAL PLACEMENT FOR ALL ASSEMBLIES WITH THE -LC OPTION."

UNLESS OTHERWISE SPECIFIED, DIMENSIONS ARE IN INCHES. TOLERANCES ARE:  
 DECIMALS ANGLES  
 .XX: ±.01 [3] 2°  
 .XXX: ±.005 [13]  
 .XXXX: ±.0020 [051]

**PROPRIETARY NOTE**  
 THIS DOCUMENT CONTAINS CONFIDENTIAL AND PROPRIETARY INFORMATION AND ALL DESIGN, MANUFACTURING, REPRODUCTION, USE, PATENT RIGHTS AND SALES RIGHTS ARE EXPRESSLY RESERVED BY SAMTEC, INC. THIS DOCUMENT SHALL NOT BE DISCLOSED, IN WHOLE OR PART, TO ANY UNAUTHORIZED PERSON OR ENTITY NOR REPRODUCED, TRANSFERRED OR INCORPORATED IN ANY OTHER PROJECT IN ANY MANNER WITHOUT THE EXPRESS WRITTEN CONSENT OF SAMTEC, INC.

**MATERIAL:** DO NOT SCALE DRAWING SHEET SCALE: 3:2  
 INSULATOR: BLACK, LCP  
 FLAMMABILITY RATING: UL94V0  
 TERMINAL: PHOS BRONZE  
 GROUND PLANE: PHOS BRONZE

F:\DWG\MISC\MKTG\QSH-XXX-XX-X-D-DP-XXX-MKT.SLDDRW

520 PARK EAST BLVD. NEW ALBANY, IN 47150  
 PHONE: 812-944-6733 FAX: 812-948-5047  
 e-Mail info@SAMTEC.com code 55322

**DESCRIPTION:**  
 .5mm DIFFERENTIAL PAIRS HS SOCKET ASSEMBLY

DWG. NO.  
**QSH-XXX-XX-X-D-DP-XXX**

BY: KEVIN B 06/13/00 SHEET 1 OF 4

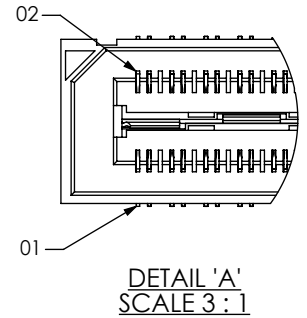
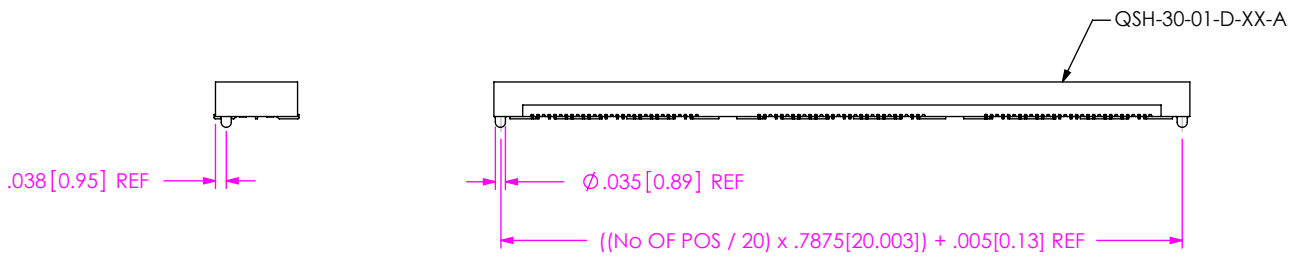

FIG 2  
-A: ALIGNMENT PIN OPTION SHOWN

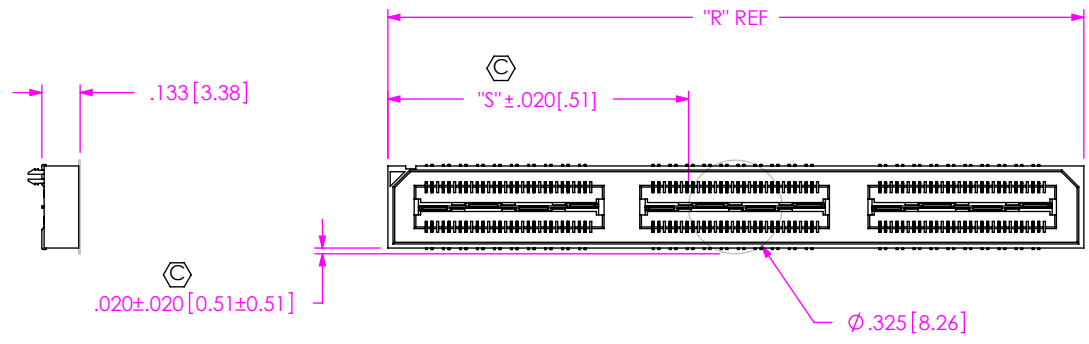



FIG 3  
-K: POLYIMIDE FILM PAD

NOTE: "R" = ((No OF POSITIONS / 20) x .7875[20.003]) + .050[1.27]  
 "S" = (( "R" - .325[8.26] ) / 2) ± .020[.51]

DO NOT SCALE DRAWING  SHEET SCALE: 1.5:1	* PROPRIETARY NOTE * THIS DOCUMENT CONTAINS CONFIDENTIAL AND PROPRIETARY INFORMATION AND ALL DESIGN, MANUFACTURING, REPRODUCTION, USE, PATENT RIGHTS AND SALES RIGHTS ARE EXPRESSLY RESERVED BY SAMTEC, INC. THIS DOCUMENT SHALL NOT BE DISCLOSED, IN WHOLE OR PART, TO ANY UNAUTHORIZED PERSON OR ENTITY NOR REPRODUCED, TRANSFERRED OR INCORPORATED IN ANY OTHER PROJECT IN ANY MANNER WITHOUT THE EXPRESS WRITTEN CONSENT OF SAMTEC, INC.	 520 PARK EAST BLVD, NEW ALBANY, IN 47150 PHONE: 812-944-6733 FAX: 812-948-5047 e-Mail info@SAMTEC.com code 55322
	DESCRIPTION: .5mm DIFFERENTIAL PAIRS HS SOCKET ASSEMBLY	
	DWG. NO. QSH-XXX-XX-X-D-DP-XXX	
	BY: KEVIN B 06/13/00	SHEET 2 OF 4

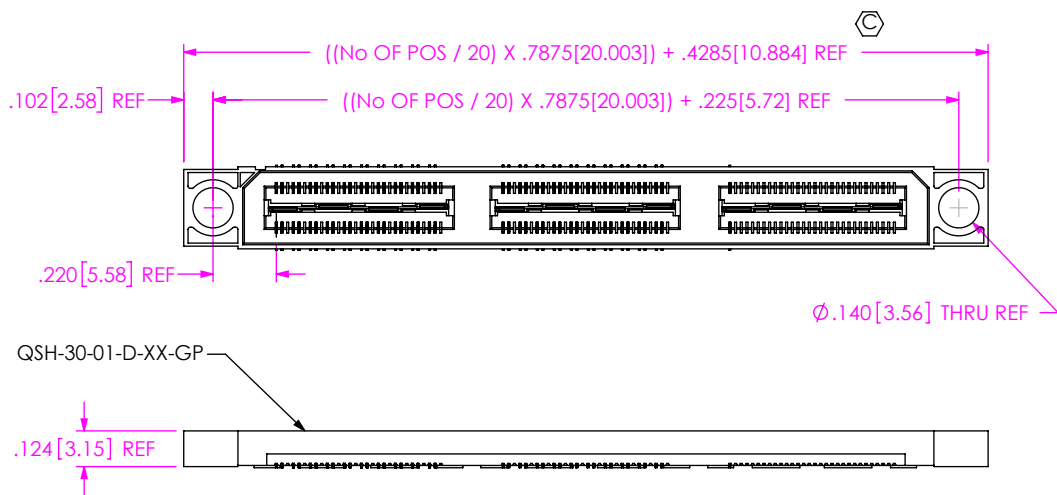
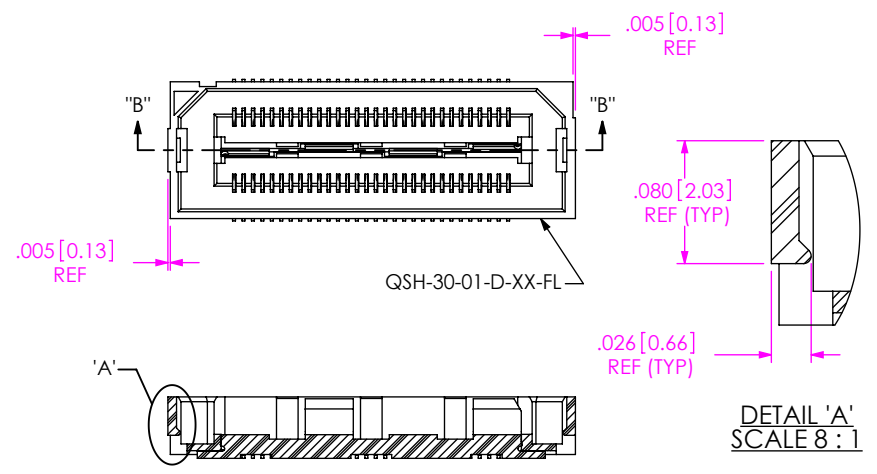
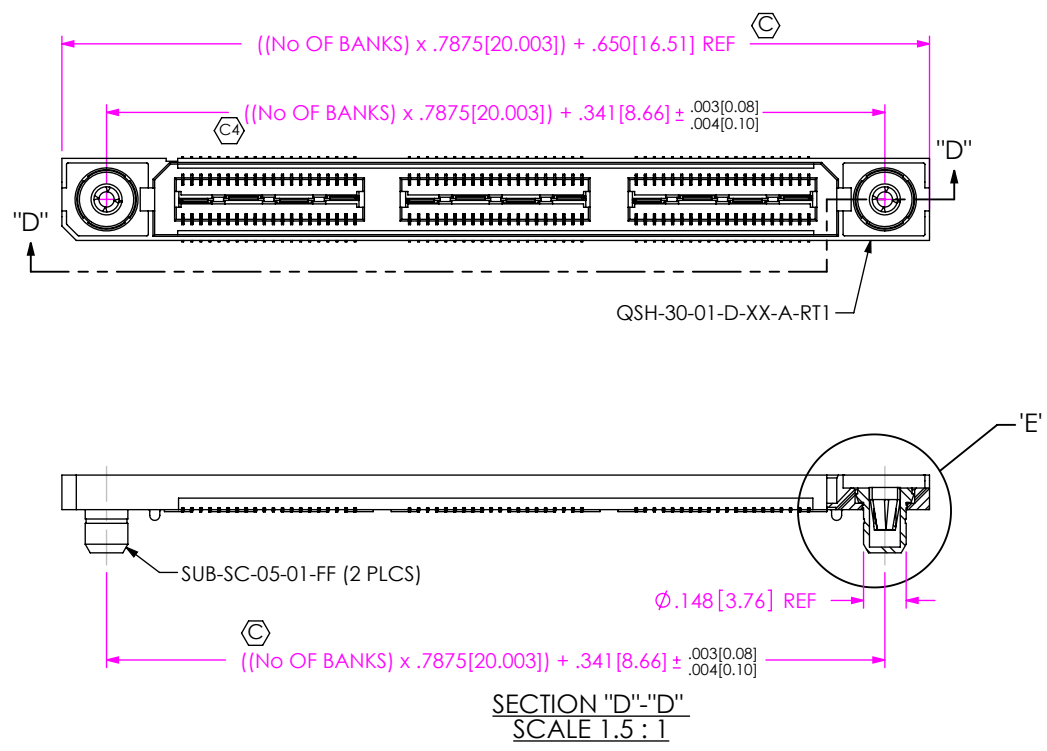

FIG 4  
-GP: GUIDE POST OPTION SHOWN



SECTION "B"-"B"  
FIG 5  
-FL: FRICTION LOCKS  
(NOT AVAILABLE WITH -GP OPTION)  
(SAME AS FIG 1, UNLESS OTHERWISE STATED)



SECTION "D"-"D"  
SCALE 1.5 : 1

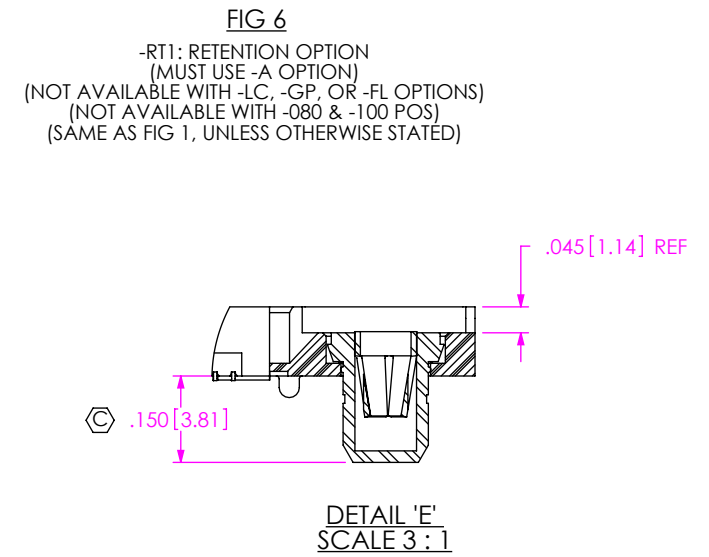

DETAIL 'E'  
SCALE 3 : 1

<p>PROPRIETARY NOTE</p> <p>THIS DOCUMENT CONTAINS CONFIDENTIAL AND PROPRIETARY INFORMATION AND ALL DESIGN, MANUFACTURING, REPRODUCTION, USE, PATENT RIGHTS AND SALES RIGHTS ARE EXPRESSLY RESERVED BY SAMTEC, INC. THIS DOCUMENT SHALL NOT BE DISCLOSED, IN WHOLE OR PART, TO ANY UNAUTHORIZED PERSON OR ENTITY NOR REPRODUCED, TRANSFERRED OR INCORPORATED IN ANY OTHER PROJECT IN ANY MANNER WITHOUT THE EXPRESS WRITTEN CONSENT OF SAMTEC, INC.</p>		
	<p>520 PARK EAST BLVD. NEW ALBANY, IN 47150 PHONE: 812-944-6733 FAX: 812-948-5047 e-Mail info@SAMTEC.com code 55322</p>	
	<p>DO NOT SCALE DRAWING</p> <p>SHEET SCALE: 1:25:1</p>	<p>DESCRIPTION: .5mm DIFFERENTIAL PAIRS HS SOCKET ASSEMBLY</p> <p>DWG. NO. <b>QSH-XXX-XX-X-D-DP-XXX</b></p> <p>BY: KEVIN B 06/13/00 SHEET 3 OF 4</p>

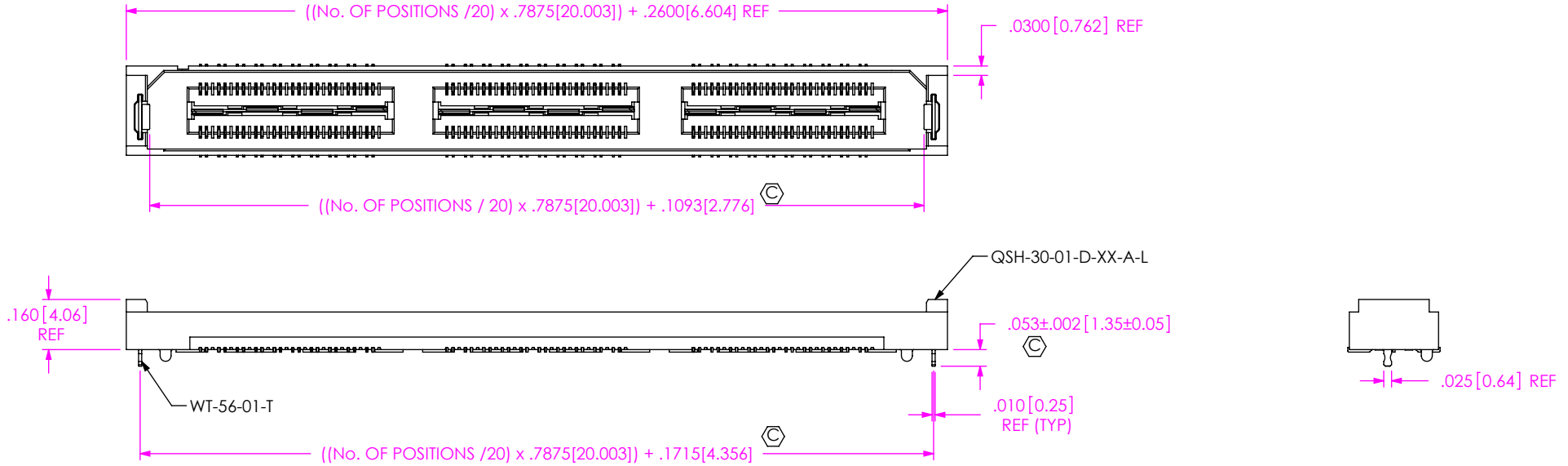

FIG 7  
 -L: RETENTION OPTION  
 (NOT AVAILABLE WITH -LC, -GP, -FL, OR -RT1 OPTIONS)  
 (SAME AS FIG 1, UNLESS OTHERWISE STATED)

<p>• PROPRIETARY NOTE •          THIS DOCUMENT CONTAINS CONFIDENTIAL AND PROPRIETARY INFORMATION AND ALL DESIGN, MANUFACTURING, REPRODUCTION, USE, PATENT RIGHTS AND SALES RIGHTS ARE EXPRESSLY RESERVED BY SAMTEC, INC. THIS DOCUMENT SHALL NOT BE DISCLOSED, IN WHOLE OR PART, TO ANY UNAUTHORIZED PERSON OR ENTITY NOR REPRODUCED, TRANSFERRED OR INCORPORATED IN ANY OTHER PROJECT IN ANY MANNER WITHOUT THE EXPRESS WRITTEN CONSENT OF SAMTEC, INC.</p>	<p><b>samtec</b>          520 PARK EAST BLVD, NEW ALBANY, IN 47150          PHONE: 812-944-6733 FAX: 812-948-5047          e-Mail info@SAMTEC.com code 55322</p>
<p>DO NOT SCALE DRAWING          SHEET SCALE: 2:1</p>	<p>DESCRIPTION:          .5mm DIFFERENTIAL PAIRS HS SOCKET ASSEMBLY          DWG. NO.  <b>QSH-XXX-XX-X-D-DP-XXX</b>          BY: KEVIN B 06/13/00 SHEET 4 OF 4</p>