

THIS DRAWING IS UNPUBLISHED. RELEASED FOR PUBLICATION 20
 © COPYRIGHT 20 BY - ALL RIGHTS RESERVED.

REVISIONS					
P	LTR	DESCRIPTION	DATE	DWN	APVD
	H10	REVISED PER ECO-14-018223	10DEC2014	NK	MM

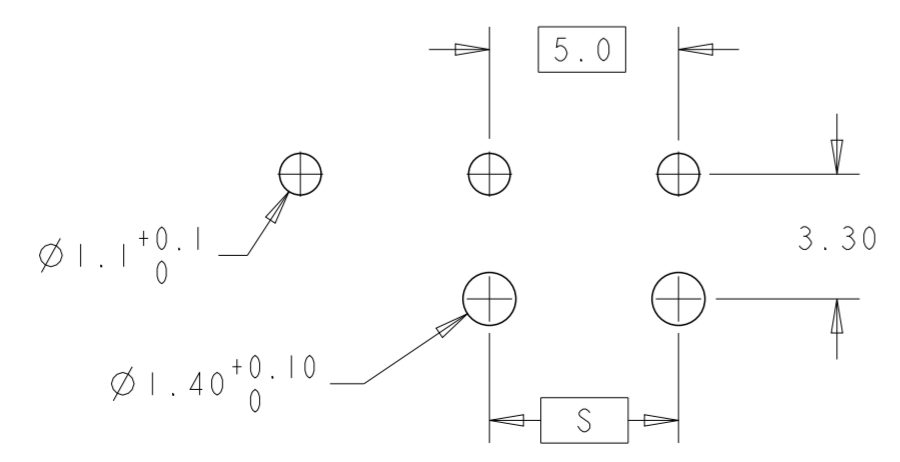
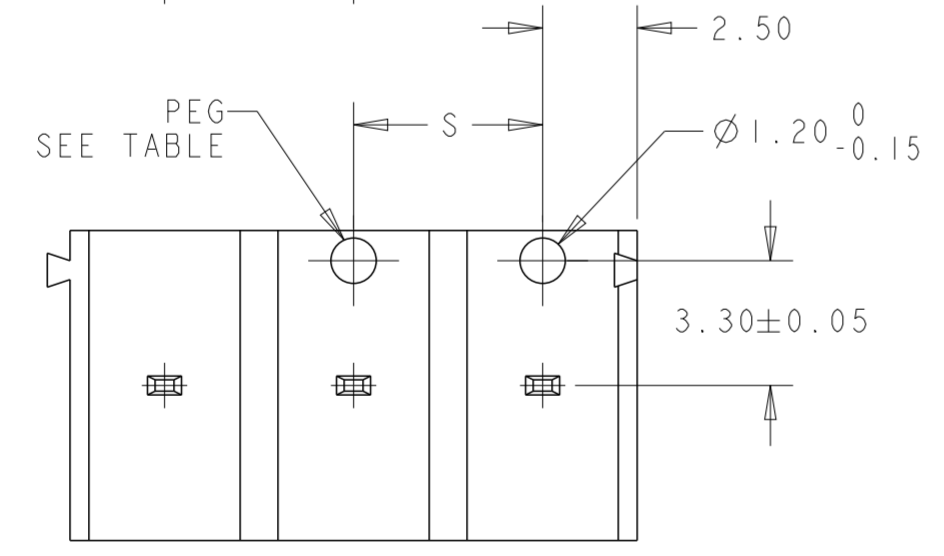
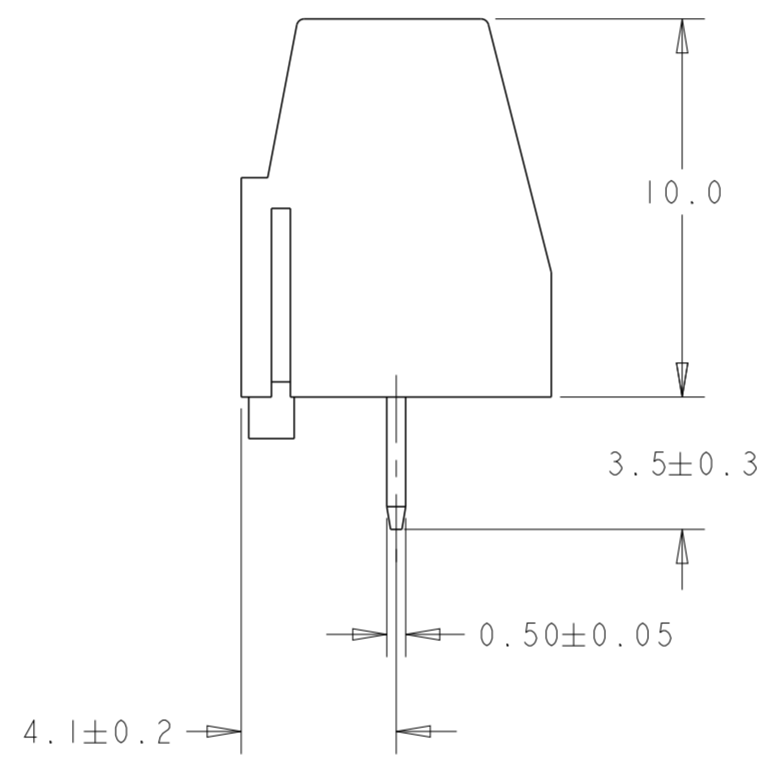
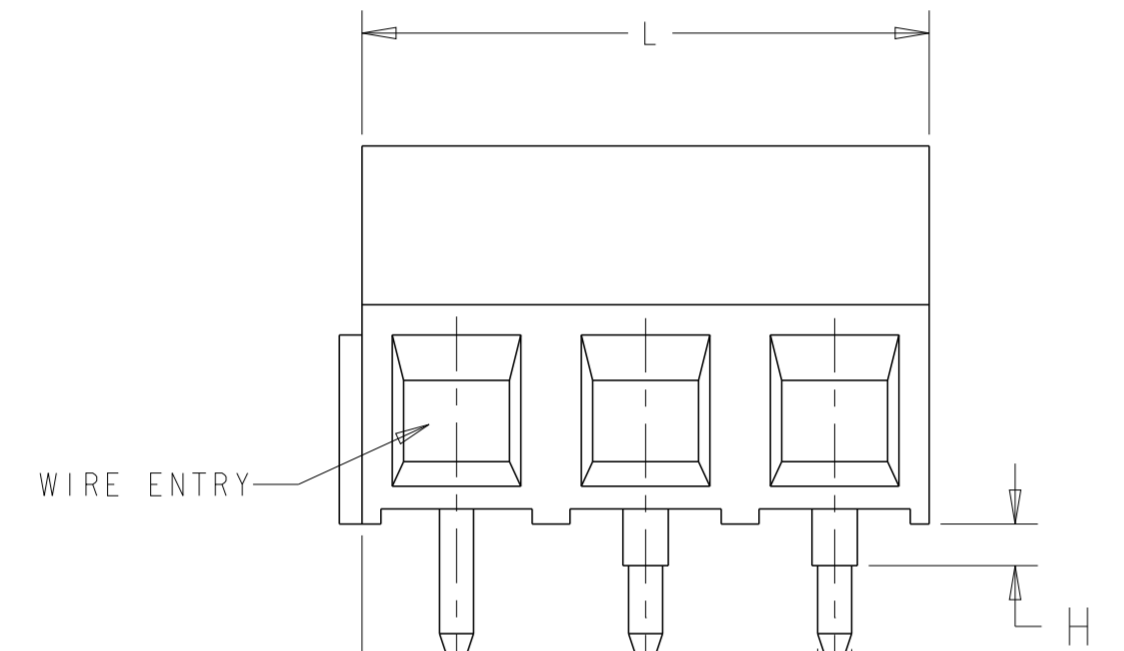
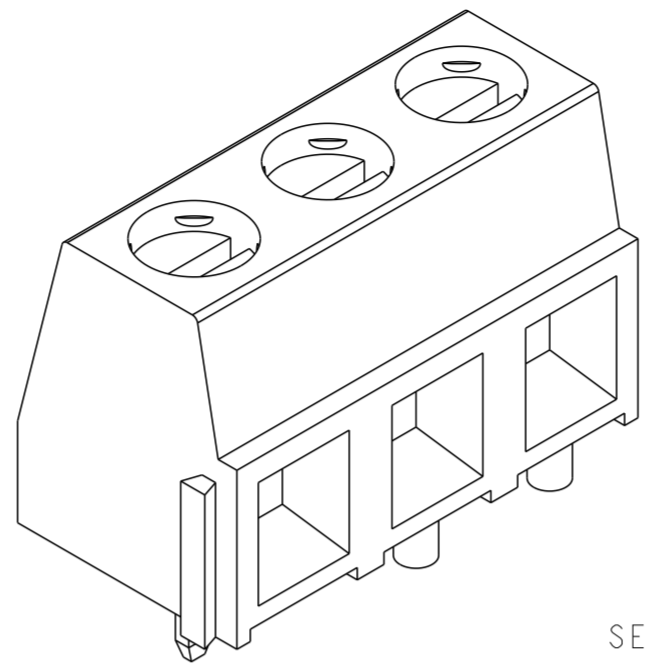
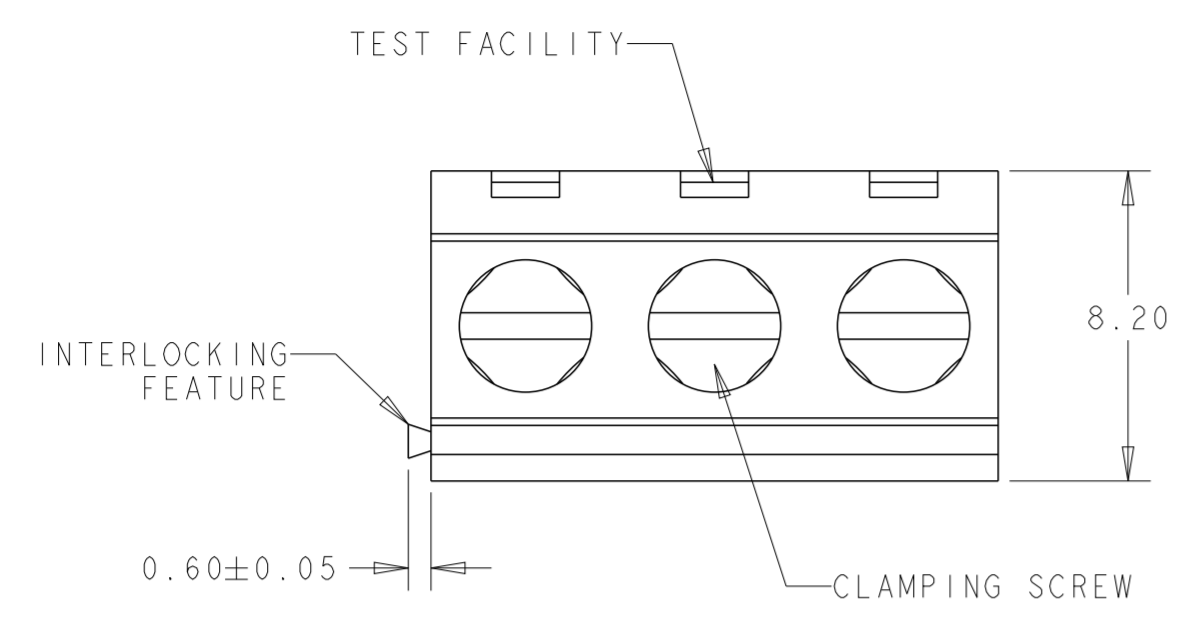

RECOMMENDED PC BOARD LAYOUT

QTY	S	H	MARKING	L	NO OF POSN	PART NUMBER
-	-	-	SEE SHEET 2	10	2	3-1986874-2
-	-	-	SEE SHEET 2	55	11	1-1986874-1
-	-	-	SEE SHEET 2	10	2	1986874-2
1	N/A	3.5	-	35	7	3-282836-7
1	N/A	3.5	SEE SHEET 2	15	3	3-282836-5
1	N/A	3.5	-	30	6	3-282836-4
1	N/A	3.5	-	25	5	3-282836-3
1	N/A	3.5	-	20	4	3-282836-2
1	N/A	3.5	-	10	2	3-282836-1
1	N/A	3.5	-	40	8	3-282836-0
1	N/A	3.5	-	45	9	2-282836-8
0	N/A	N/A	SEE SHEET 2	30	6	2-282836-7
0	N/A	N/A	-	125	25	2-282836-6
0	N/A	N/A	-	120	24	2-282836-5
0	N/A	N/A	-	115	23	2-282836-4
0	N/A	N/A	-	110	22	2-282836-3
0	N/A	N/A	-	105	21	2-282836-2
0	N/A	N/A	-	100	20	2-282836-1
0	N/A	N/A	-	95	19	2-282836-0
0	N/A	N/A	-	90	18	1-282836-9
0	N/A	N/A	-	85	17	1-282836-8
0	N/A	N/A	-	80	16	1-282836-7
0	N/A	N/A	-	75	15	1-282836-6
0	N/A	N/A	-	70	14	1-282836-5
0	N/A	N/A	-	65	13	1-282836-4
0	N/A	N/A	SEE SHEET 2	10	2	1-282836-3
0	N/A	N/A	-	60	12	1-282836-2
0	N/A	N/A	-	55	11	1-282836-1
0	N/A	N/A	-	50	10	1-282836-0
0	N/A	N/A	-	45	9	282836-9
0	N/A	N/A	-	40	8	282836-8
0	N/A	N/A	-	35	7	282836-7
0	N/A	N/A	-	30	6	282836-6
0	N/A	N/A	-	25	5	282836-5
0	N/A	N/A	-	20	4	282836-4
0	N/A	N/A	-	15	3	282836-3
0	N/A	N/A	-	10	2	282836-2
2	5.0	1.1	-	10	2	282836-1

THIS DRAWING IS A CONTROLLED DOCUMENT.

DWN S. WELDON 28SEP2007
 CHK C. RICHARD 28SEP2007
 APVD C. RICHARD 28SEP2007

STE TE Connectivity

NAME: TERMINAL BLOCK, PCB MOUNT, SIDE WIRE ENTRY, STACKING WITH INTERLOCK, 5.00mm PITCH

SIZE: A2 CAGE CODE: 00779 DRAWING NO: C-282836

RESTRICTED TO: -

MATERIAL: 1

TOLERANCES UNLESS OTHERWISE SPECIFIED:
 0 PLC ±0.2
 1 PLC ±0.15
 2 PLC ±0.15
 3 PLC ±0.000
 4 PLC ±0.000
 ANGLES ±2°
 FINISH: -

PRODUCT SPEC: -
 APPLICATION SPEC: -
 WEIGHT: -

Customer Drawing SCALE 4:1 SHEET 1 OF 3 REV H10

REVISIONS				
P	LTR	DESCRIPTION	DATE	APVD
-	-	SEE SHEET 1	-	-

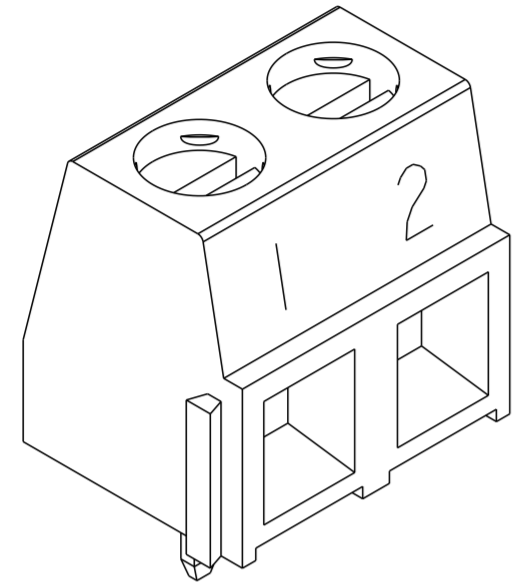

1-282836-3 AS SHOWN

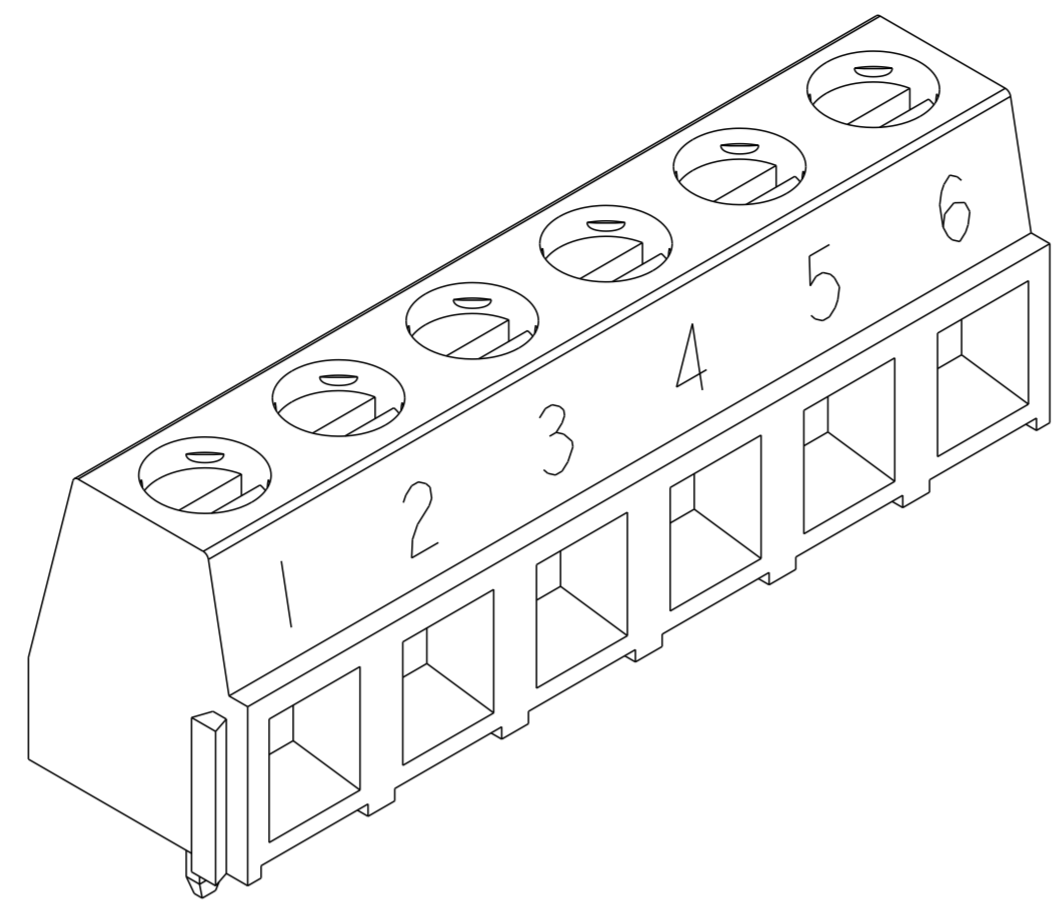

2-282836-7 AS SHOWN

- 1 MATERIAL AND FINISH
 HOUSING: PA 6-6, U; 94V-0 RATED, COLOR: GREEN.
 CLAMP: BRASS, NICKEL PLATED.
 TERMINAL: BRASS, TIN PLATED.
 CLAMPING SCREW: M3, BRASS, NICKEL PLATED.
- 2 SUITABLE FOR 1.6-2.4mm PCB BOARD THICKNESS.
- 3 END-TO-END STACKABLE W/INTERLOCK WITHOUT LOSS OF CENTERLINE SPACING.
- 4 WIRE SIZE RANGE: 16-30 AWG
- 5 RECOGNIZED UNDER THE COMPONENT PROGRAM OF UNDERWRITERS LABORATORIES INC. FILE No E60677.
- 6 IMQ CERTIFICATE WITH SURVEILLANCE IN CONFORMITY WITH IEC 998-1/998-1-1.
- 7 NOT CUMULATIVE TOLERANCE.
- 8 INK MARKING, WHITE COLOR, UNLESS OTHERWISE SPECIFIED. NUMERICAL SEQUENCE FROM LEFT TO RIGHT, UNLESS OTHERWISE SPECIFIED.
- 9 INK MARKING, BLACK COLOR

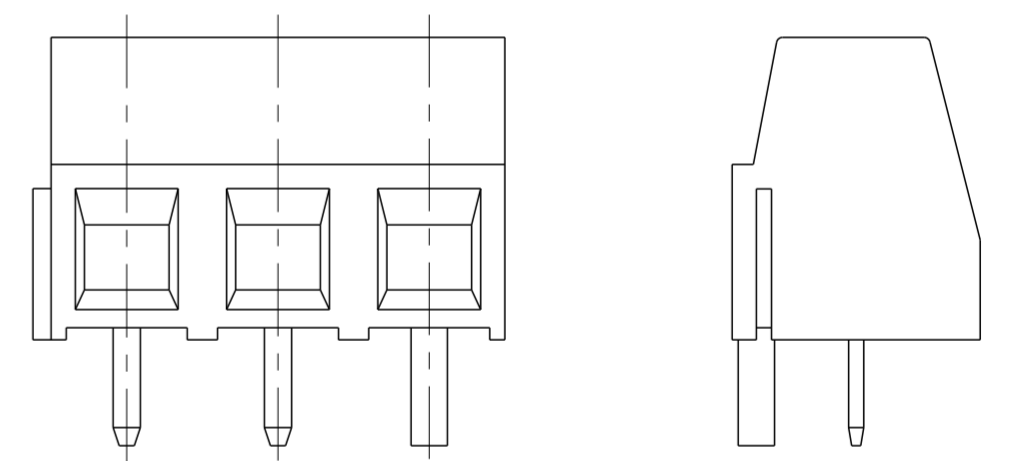
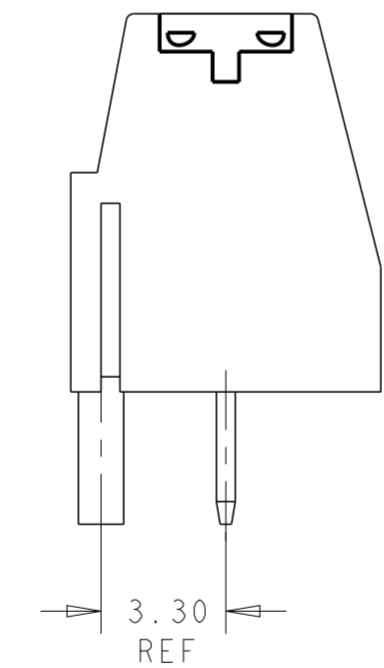
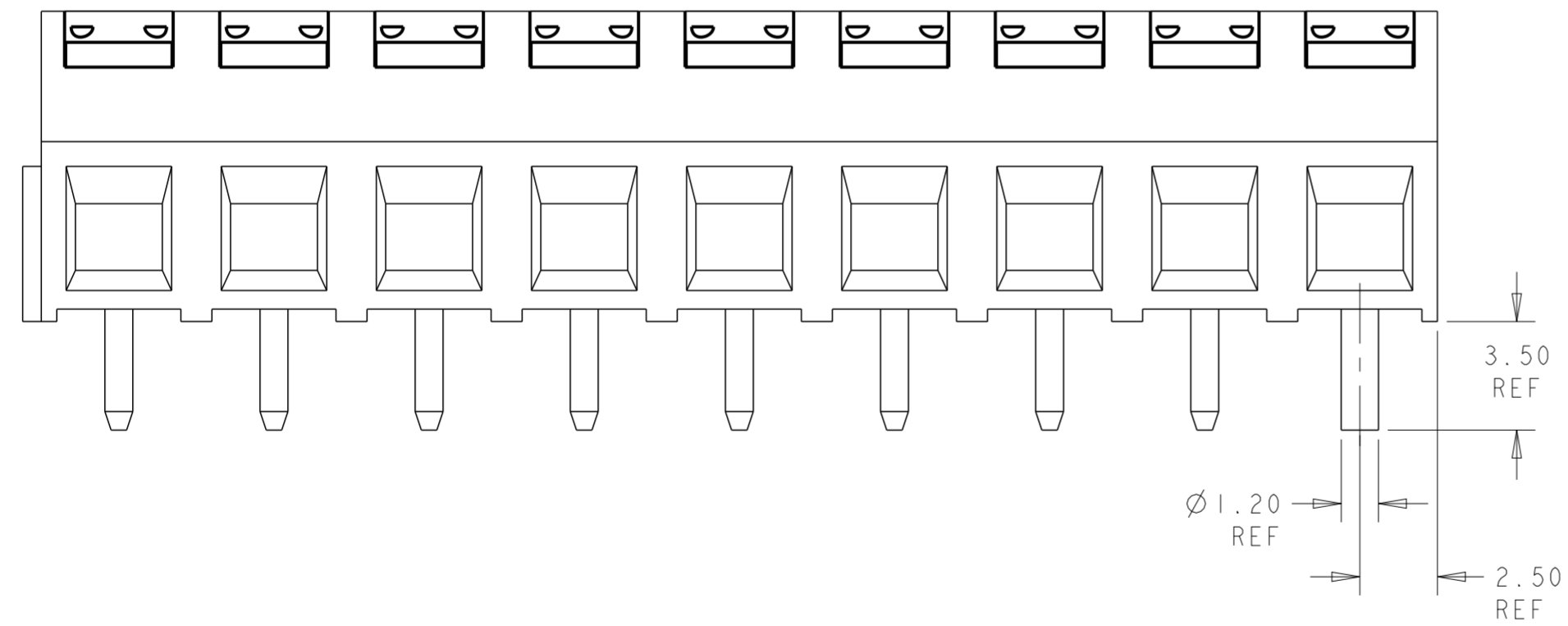

3-282836-5 AS SHOWN

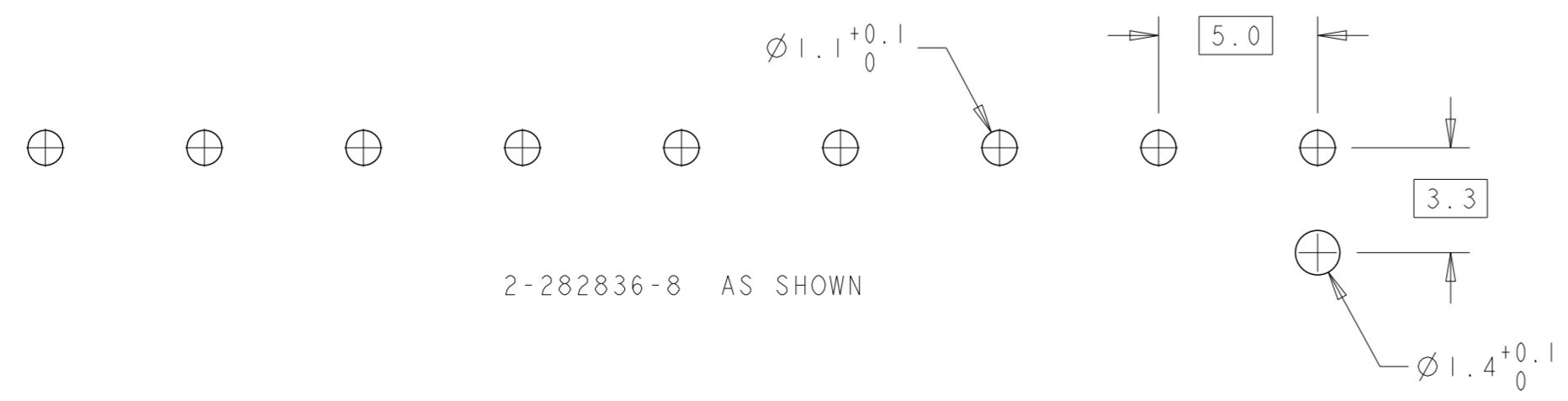

2-282836-8 AS SHOWN

THIS DRAWING IS A CONTROLLED DOCUMENT.		DWN S. WELDON 28SEP2007	TE Connectivity	
DIMENSIONS: mm		CHK C. RICHARD 28SEP2007		
TOLERANCES UNLESS OTHERWISE SPECIFIED:		APVD C. RICHARD 28SEP2007	NAME	
0 PLC ±	1 PLC ±0.2	PRODUCT SPEC	TERMINAL BLOCK, PCB MOUNT, SIDE WIRE ENTRY, STACKING WITH INTERLOCK, 5.00mm PITCH	
2 PLC ±0.15	3 PLC ±0.000	APPLICATION SPEC	SIZE	RESTRICTED TO
4 PLC ±0.000	ANGLES ±	WEIGHT	A200779	C-282836
FINISH		Customer Drawing	SCALE 5:1	SHEET 2 OF 3
				REV H10

THIS DRAWING IS UNPUBLISHED. RELEASED FOR PUBLICATION 20
 © COPYRIGHT 20 BY - ALL RIGHTS RESERVED.

REVISIONS				
P	LTR	DESCRIPTION	DATE	APVD
-		SEE SHEET 1	-	-

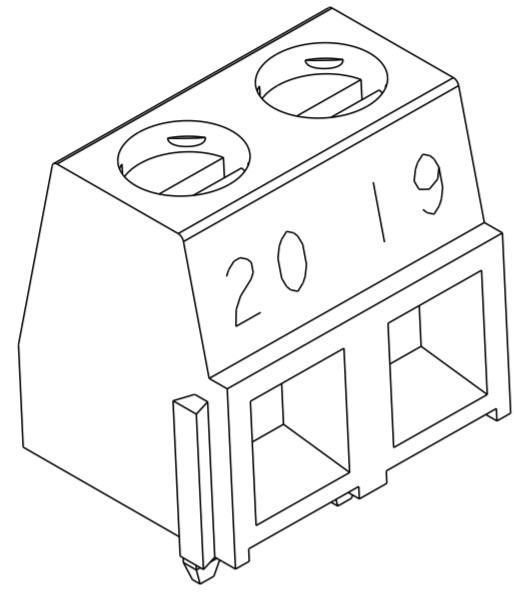

3-1986874-2 AS SHOWN

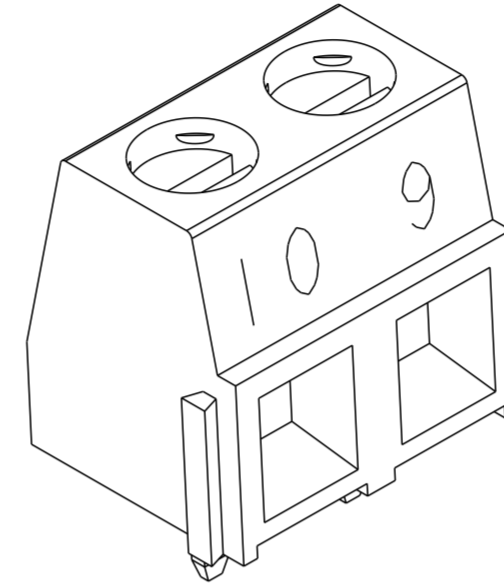

1986874-2 AS SHOWN

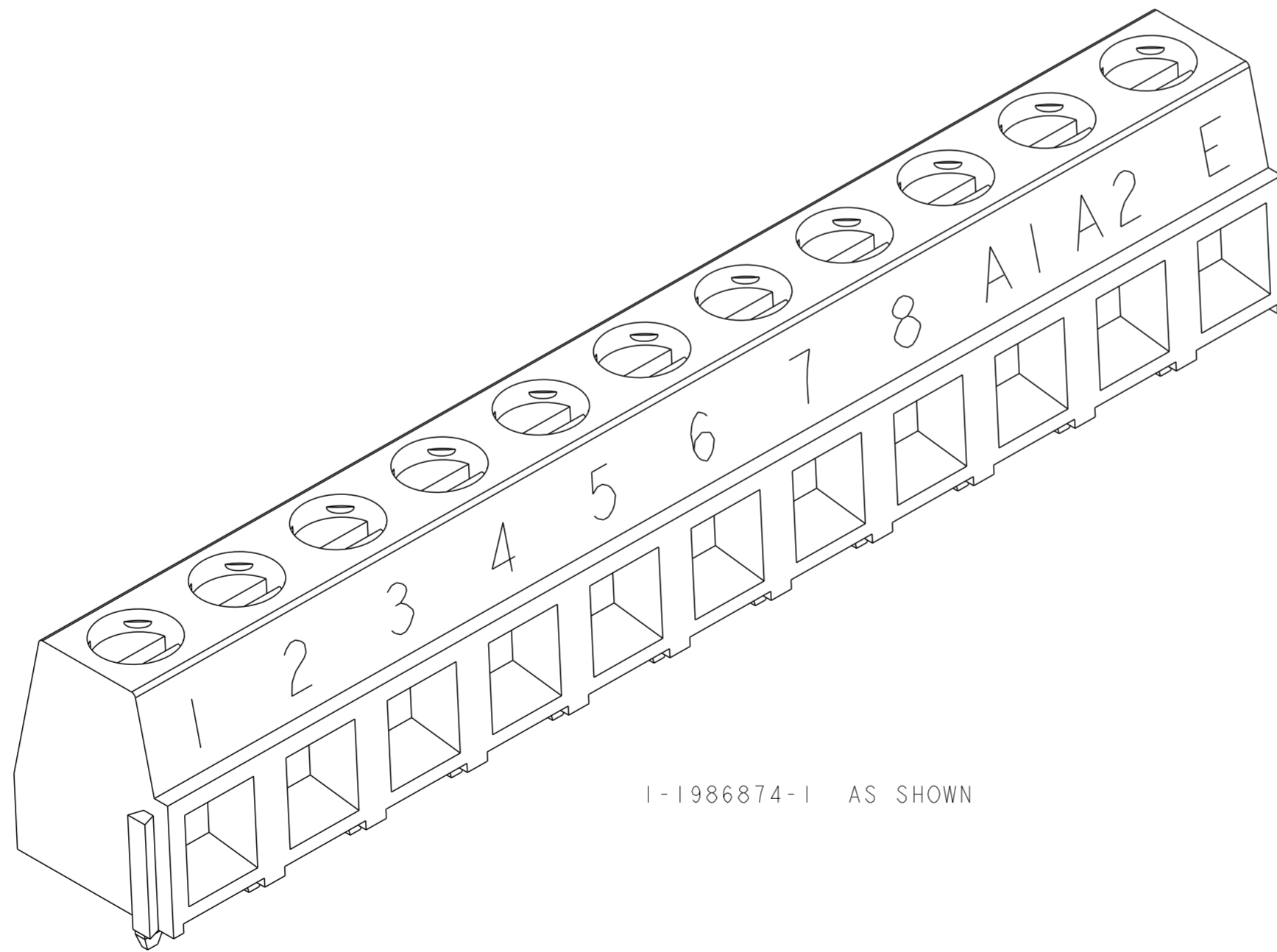

1-1986874-1 AS SHOWN

THIS DRAWING IS A CONTROLLED DOCUMENT.		DWN S. WELDON 28SEP2007	 TE Connectivity	
DIMENSIONS: mm		CHK C. RICHARD 28SEP2007		
TOLERANCES UNLESS OTHERWISE SPECIFIED:		APVD C. RICHARD 28SEP2007	NAME TERMINAL BLOCK, PCB MOUNT, SIDE WIRE ENTRY, STACKING WITH INTERLOCK, 5.00mm PITCH	
0 PLC ± 1 PLC ±0.2 2 PLC ±0.15 3 PLC ±0.000 4 PLC ±0.000 ANGLES ± FINISH		PRODUCT SPEC -	SIZE A200779	CAGE CODE C-282836
MATERIAL		APPLICATION SPEC -	DRAWING NO C-282836	RESTRICTED TO -
		WEIGHT -	SCALE 5:1	SHEET 3 OF 3
		Customer Drawing	REV H10	

Mouser Electronics

Authorized Distributor

Click to View Pricing, Inventory, Delivery & Lifecycle Information:

[TE Connectivity:](#)

[282836-1](#)