

The thinnest possible body contributes to reduced size, height and weight of the set product



■ Typical Specifications



Items	Specifications
Total resistance tolerance	±20%
Maximum operating voltage	200V AC, 10V DC (RS60N Series) 500V AC, 10V DC (RSA0N Series)
Operating force	0.3 <sup>+0.5</sup> <sub>-0.25</sub> N
Operating life	30,000 cycles
Operating temperature range	-10°C to +60°C

■ Product Line

Number of resistor elements	Travel (mm)	Lever type	Length of lever (mm)	Total resistance (kΩ)	Resistance taper	Terminal style	Minimum order unit (pcs.)		Products No.	Drawing No.
							Japan	Export		
Single-unit	60	4	20	10	1B	For PC board	600	1,200	<b>RS60N11S4006</b>	1
	100	9-T (T-Bar)	8.2				400	800	<b>RSA0N11S9A0K</b>	2

Note

Other varieties are also available. Refer to "Other Specifications" (P.406).

■ Packing Specifications

Tray

Travel (mm)	Number of packages (pcs.)		Export package measurements (mm)
	1 case /Japan	1 case /export packing	
60	600	1,200	517×377×371
100	400	800	

■ Dimensions

Unit:mm

No.	Style	PC board mounting hole dimensions (Viewed from mounting side)
1		

Refer to P.406 for other specifications.  
Refer to P.407 for ordering products not listed.  
Refer to P.417 for soldering conditions.

Rotary Potentiometers  
 Slide Potentiometers  
 General-use  
 Mixer

■ Dimensions

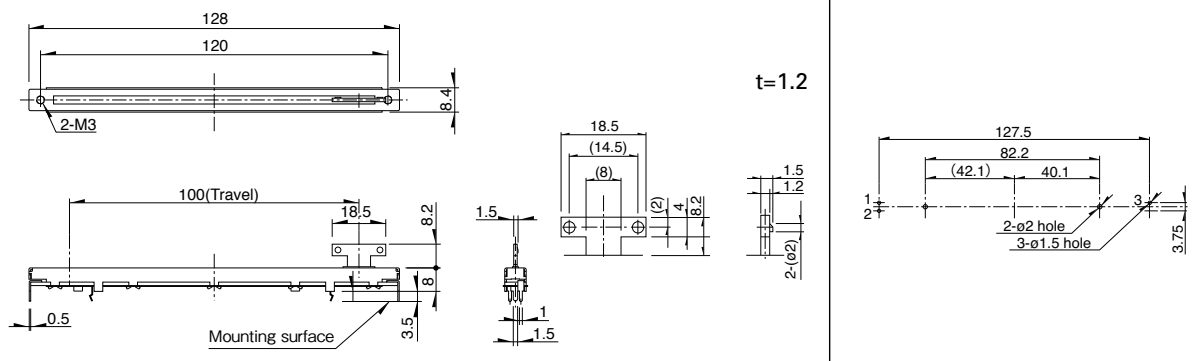
No.	Style	PC board mounting hole dimensions (Viewed from mounting side)
2		

Low-profile Master Type (Slim Type) / Other Specifications

In addition to the products listed, we can accommodate the follow specifications.

■ Total Resistance Variety

Total resistance (k Ω)	10	50	100	250
------------------------	----	----	-----	-----

■ Resistance Taper

Resistance taper	15A	1B	10A
------------------	-----	----	-----

■ Lever Types

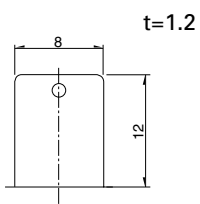
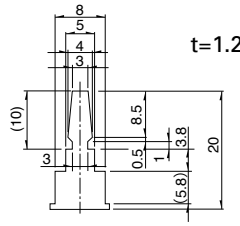
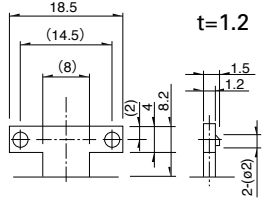
Configuration code	1	4	9-T (T-Bar)
Dimensions			

■ Corresponding Specification

Dust cover	Available
------------	-----------

■ Terminal Layout / Circuit Diagram

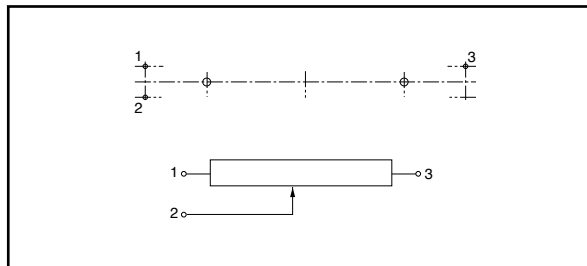

Note

Marked are specifications recommended by Alps Alpine.

# Low-profile Master Type (Slim Type) / Ordering Products Not Listed

When ordering product varieties that are not listed, specify referring to the examples below.

## Sample Part Number

**R S 6 0 N 1 1 S - 0 1 - B 1 0 3**

Travel

60	60mm
A0	100mm

Number of resistor elements

Single-unit	1
-------------	---

Lever types

Code	Configuration code
01	1
04	4
9T	9-T (T-Bar)

Resistance taper



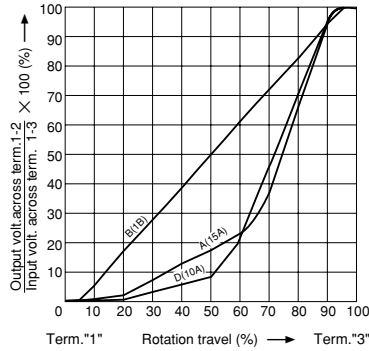







Code	Resistance taper
A	15A
B	1B
D	10A



Total resistance

Code	Total resistance (k Ω)	Code	Total resistance (k Ω)
103	10	104	100
503	50	254	250

Rotary Potentiometers  
 Slide Potentiometers  
 General-use  
 Mixer

Type		Low-profile Master Type		Motor-driven Master Type		
Series		Slim Type	Super P Fader	Motor N Fader	Motor K Fader	Motor V Fader
		<b>RS □□ N11S</b>	<b>RS6011 □ P</b>	<b>RS □□ N1 □ M</b>	<b>RSA0K1 □ V</b>	<b>RSA0V11M</b>
		Single-unit	Single-unit/Dual-unit	Single-unit/Dual-unit	Single-unit/Dual-unit	Single-unit
Photo						
Travel (mm)		60, 100	60	60, 100	100	
Direction of lever		Vertical				
Lever material		Metal				Resin
Operating temperature range		-10°C to +60°C				
Operating life		30,000 cycles			300,000 cycles	100,000 cycles
Available for automotive use		—	—	—	—	—
Life cycle						
Electrical performance	Total resistance (k Ω)	10, 50, 100, 250	10, 20, 50	10, 50, 100, 250	10	
	Resistance taper	15A, 1B, 10A		Single-unit: 1B Dual-unit: Servo 1B Audio 15A, 1B, 10A		1B
	Rated Power	0.2W (RS60N11S) 0.5W (RSA0N11S)	0.2W (Single-unit) 0.1W (Dual-unit)	0.2W (RS60N1□M) 0.5W (RSA0N1□M)	0.5W	
	Insulation resistance	100MΩ min. 250V DC				
	Voltage proof	250V AC for 1 minute				
	Center-taps	Without				
Mechanical performance	Operating force	0.3 <sup>+0.5</sup> <sub>-0.25</sub> N	0.5 <sup>+1.0</sup> <sub>-0.4</sub> N	0.8±0.5N	Single-unit: 0.4±0.25N Dual-unit: 0.25 to 0.9N	—
	Center detent	Without				
	Stopper strength	100N				10N
	Lever push-pull strength	50N				20N
	Lever wobble (mm) * Both sides	$\frac{2(2 \times L)}{25}$				
	Lever deviation (mm)	0.5 max. (One side)				
Terminal style		Insertion		Lead, Insertion	Connector (Fader) Lead (Motor)	Connector
Page		405	408	411		

Slide Potentiometers Soldering Conditions	417
Potentiometer Cautions	418
Potentiometers Measurement and Test Methods	420
Potentiometers Resistance Taper	422

### Notes

- Attenuation is specified for residual resistance.
- "L" in the "Lever Wobble" column of the above table indicates the length of lever.

## Reference for Manual Soldering

Series	Tip temperature	Duration of Soldering time	No. of solders
RS□□1, RS08U, RS□□K (Standard), RS□□N, RS□□N11S, RS6011□P, RS□□N1□M, RSA0K1□V (Motor terminal)	350°C max.	3s max.	1 time

## Reference for Dip Soldering

Series	Preheating		Dip soldering		Number of soldering
	Soldering surface temperature	Heating time	Soldering temperature	Soldering time	
RS□□1, RS□□N, RS□□N11S, RS6011□P, RS□□N1□M	100°C max.	1 min. max.	260°C	5s max.	1 time

## Example of Reflow Soldering Condition

Temperature profile

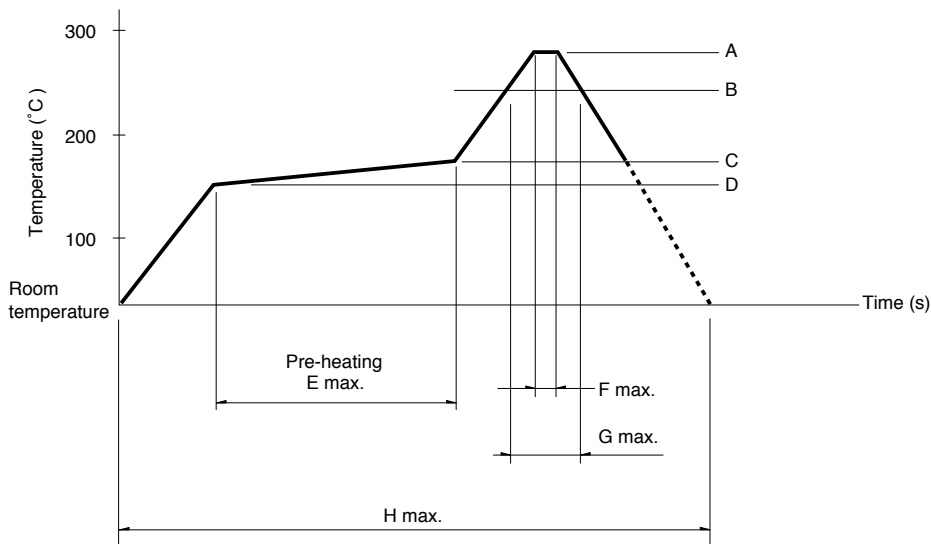

Series	A	B	C	D	E	F	G	H	No. of reflows
RS08U	250°C	200°C	150°C	150°C	2 min.	3s	40s	4 min.	1 time

## Notes

1. When using an infrared reflow oven, solder may sometimes not be applied. Be sure to use a hot air reflow oven or a type that uses infrared rays in combination with hot air.
2. The temperatures given above are the maximum temperatures at the terminals of the products when employing a hot air reflow method. The temperature of the PC board and the surface temperature of the products may vary greatly depending on the PC board material, its size and thickness. Ensure that the surface temperature of the products does not rise to 250°C or greater.
3. Conditions vary to some extent depending on the type of reflow bath used. Be sure to give due consideration to this prior to use.

# Mouser Electronics

Authorized Distributor

Click to View Pricing, Inventory, Delivery & Lifecycle Information:

ALPS:

[RSA0N11S9A0K](#) [RS60N11S4006](#)