

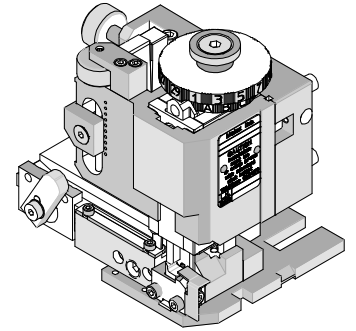

FineAdjust Applicator Specification Sheet Order No. 63900-0100



FEATURES

- Directly adapts to most automatic wire processing machines
- Quick punch removal with the push of a button for fast and easy tooling change
- Applicator designed to industry standard mounting and shut height 135.80mm (5.346")
- Quick set-up time; plus the crimp height, track and feed adjustments can be set without removing the applicator from the press
- Fine adjustment allows users to achieve target with little effort by adjusting in increments of .015mm (.0006") for conductor crimp height and .063mm (.0025") for insulation height
- Independent adjustment rings allow users to quickly adjust the conductor or insulation crimp height without affecting each other

SCOPE

Products: 2.50mm (.098") Pitch Splash Proof Crimp Terminal, 20-22 AWG.

Terminal Series No.	Terminal Order No.	Wire Size		◆ Insulation Diameter		Strip Length	
		AWG	mm ²	mm	In.	mm	In.
50038	50038-8000	20-22	0.50-0.35	1.50-1.90	.059-.075	2.00-2.50	.078-.098
50039	50039-8000	20-22	0.50-0.35	1.50-1.90	.059-.075	2.00-2.50	.078-.098

◆ Note:
 Insulation OD: 1.50-1.70mm (.059-.067") will achieve optimum IPC-A620 class 2 insulation crimps.
 Insulation OD: 1.70-1.90mm (.067-.075") will not achieve optimum IPC-A620 class 2 insulation crimps.

DEFINITION OF TERMS

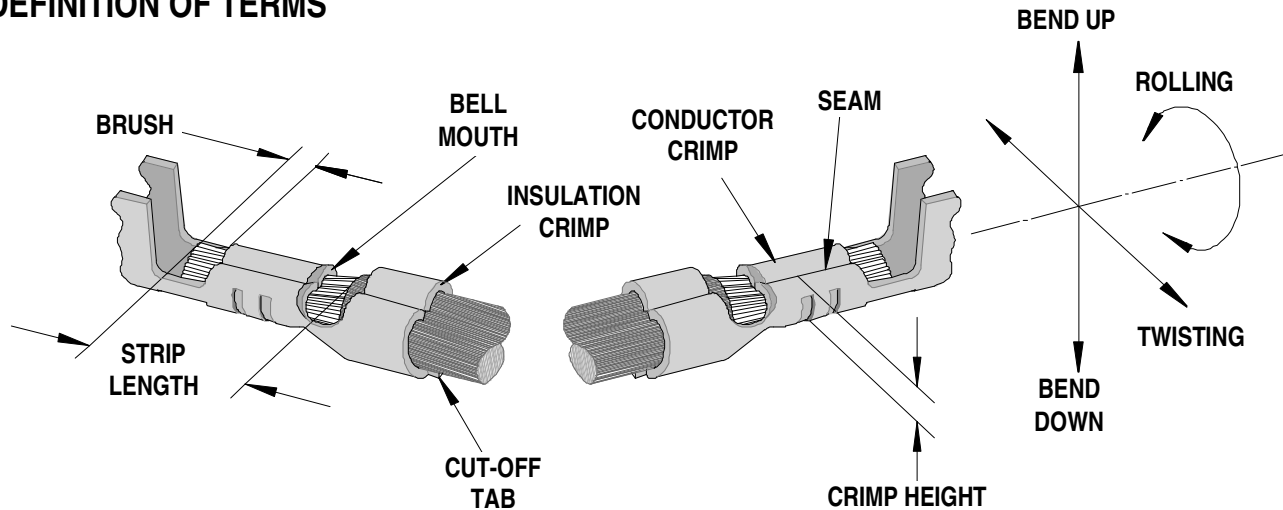

The above terminal drawing is a generic terminal representation. It is not an image of a terminal listed in the scope.

CRIMP SPECIFICATION

Terminal Series No.	Bell mouth		Cut-off Tab Maximum		Conductor Brush	
	mm	In.	mm	In.	mm	In.
50038	0.00-0.30	.000-.012	0.30	.012	0.10-0.90	.004-.035
50039	0.00-0.30	.000-.012	0.30	.012	0.10-0.90	.004-.035

Terminal Series No.	Bend up	Bend down	Twist	Roll	Punch Width mm (Ref)				Seam Seam shall not be open and no wire allowed out of the crimping area
	Degree (Max)		Degree (Max)		Conductor		Insulation		
	mm	In	mm	In	mm	In	mm	In	
50038	2	0	3	10	1.40	.055	1.80	.070	
50039	2	0	3	10	1.40	.055	1.80	.070	

After crimping, the conductor profile should measure the following.

Terminal Series No.	Wire Size		Conductor Crimp Height		Pull Force Minimum	
	AWG	mm ²	mm	In.	N	Lb.
50038	20	0.50	0.96-1.06	.038-.042	53.3	12.0
	22	0.35	0.94-0.99	.037-.039	48.9	11.0
50039	20	0.50	0.96-1.06	.038-.042	53.3	12.0
	22	0.35	0.94-0.99	.037-.039	48.9	11.0

Pull Force should be measured with no influence from the insulation crimp.

The above specifications are guidelines to an optimum crimp.

PARTS LIST

FineAdjust Applicator 63900-0100				
Item	Order No	Engineering No.	Description	Quantity
Perishable Tooling				
	63900-0170	63900-0170	Tool Kit (All "Y" Items)	REF
1	63444-1407	63444-1407	Conductor Punch	1 Y
2	63445-1426	63445-1426	Conductor Anvil	1 Y
3	63446-1808	63446-1808	Insulation Punch	1 Y
4	63445-1810	63445-1810	Insulation Anvil	1 Y
5	63443-0002	63443-0002	Cut-Off Plunger	1 Y
6	63443-0012	63443-0012	Front Plunger Retainer	1 Y
Other Components (000150)				
7	11-17-0022	1739-21	Hold Down Spring	1
8	11-18-4083	60707-8	Feed Guide	1
9	11-24-1067	4996-4	Cut-off Plunger Spring	1
10	11-24-1149	4996-37	Shank	1
11	11-40-4039	8302-5	Front Plunger Striker	1
12	63443-0009	63443-0009	Scrape Chute	1
13	63443-0025	63443-0025	Lower Tooling Key	1
14	63443-0090	63443-0090	Wire Stop	1
15	63443-1719	63443-1719	18.90mm Height Spacer	1
16	63443-2213	63443-2213	13.00mm Coarse Spacer	1
17	63443-2302	63443-2302	3.10mm Spacer	1
18	63443-2314	63443-2314	3.70mm Fine Spacer	1
19	63443-6111	63443-6111	Rear Cover	1
20	63443-7001	63443-7001	Terminal Hold Down	1
Frame				
21	63800-4901	63800-4901	Top	1
22	63801-3281	63801-3281	Base	1
23	63801-4650	63801-4650	Track	1
Hardware				
24	N/A	N/A	M3 by 6 Long SHCS	2**
25	N/A	N/A	M3 by 6 Long FHCS	1**
26	N/A	N/A	M4 by 6 Long SHCS	2**
27	N/A	N/A	M4 by 12 Long BHCS	2**
28	N/A	N/A	M5 by 12 Long SHCS	1**
29	N/A	N/A	M4 by 50 Long SHCS	2**
30	N/A	N/A	#5-40 by 3/8 Long SHCS	1**
31	N/A	N/A	#10-32 by 3/8" Long Flat Point SSS	1**
32	N/A	N/A	#10-32 Hex Jam Nut	1**
** Available from an industrial supply company such as MSC (1-800-645-7270).				

Assembly Drawing

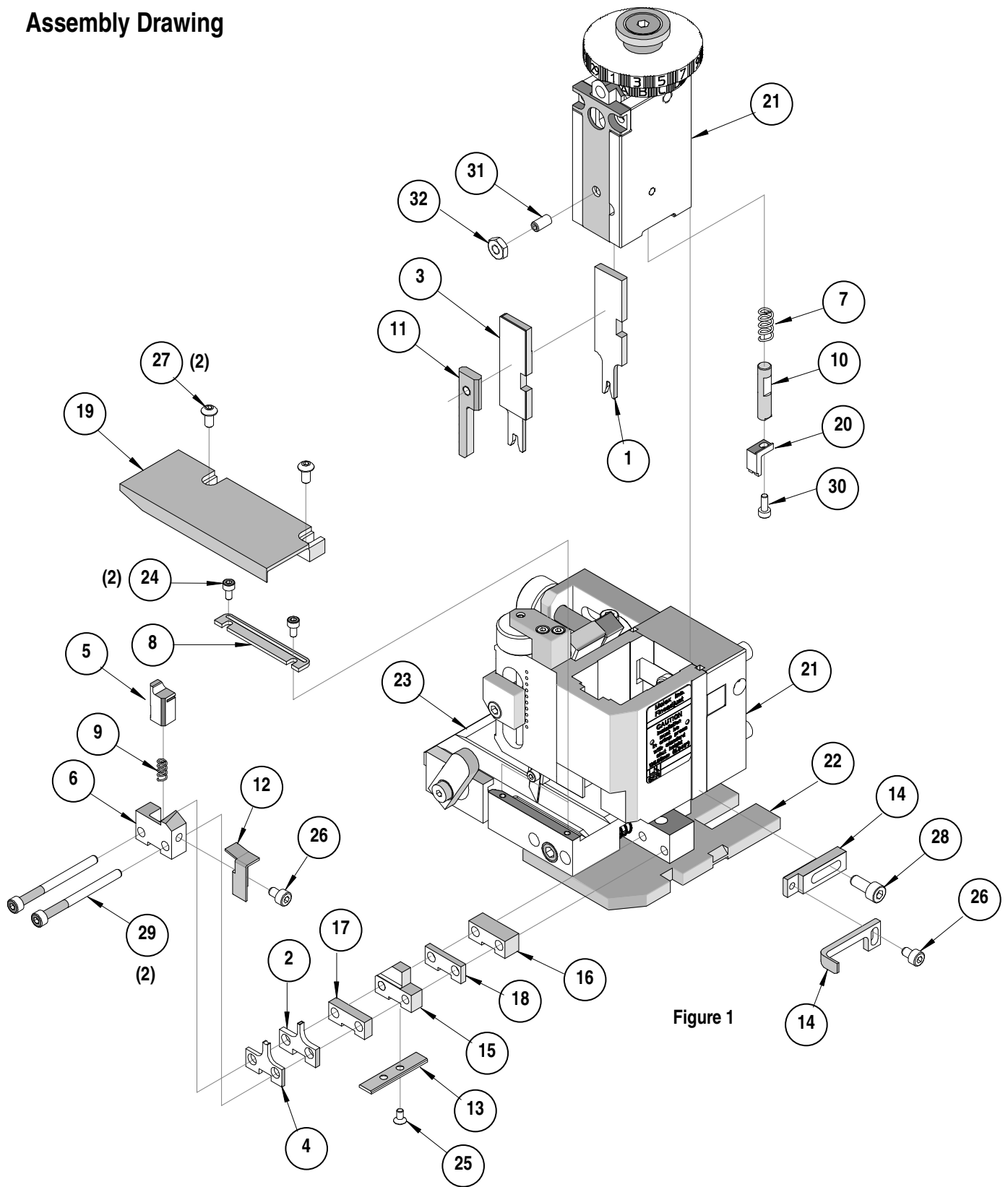

Figure 1

NOTES

1. Molex recommends an extra perishable tooling kit be maintained at your facility.
2. Verify tooling alignment by manually cycling the press and Applicator before crimping under power. Check that all screws are tight.
3. Slugs, Terminals, Dirt and Oil should be kept clear of work area.
4. Wear safety glasses at all times.
5. For recommended maintenance refer to the FineAdjust Manual.

CAUTION: This applicator should only be used in a press with a shut height of 135.8mm (5.346"). Tooling damage could result at a lower setting.

CAUTION: To prevent injury never operate this Applicator without the guards supplied with the press or wire-processing machine in place. Reference the press or wire processing manufacturer's instruction manual.

CAUTION: Molex crimp specifications are valid only when used with Molex terminals, applicators and tooling.

Americas Headquarters
Lisle, Illinois 60532 U.S.A.
1-800-78MOLEX
amerinfo@molex.com

Far East North Headquarters
Yamato, Kanagawa, Japan
81-462-65-2324
feninfo@molex.com

Far East South Headquarters
Jurong, Singapore
65-6-268-6868
fesinfo@molex.com

European Headquarters
Munich, Germany
49-89-413092-0
eurinfo@molex.com

Corporate Headquarters
2222 Wellington Ct.
Lisle, IL 60532 U.S.A.
630-969-4550
Fax: 630-969-1352

Visit our Web site at <http://www.molex.com>

Mouser Electronics

Authorized Distributor

Click to View Pricing, Inventory, Delivery & Lifecycle Information:

[Molex:](#)

[63900-0170](#)