



Improved Low Cost ±5 g Dual-Axis Accelerometer with Ratiometric Analog Outputs

MXR7305VF

FEATURES

- Dual axis accelerometer fabricated on a single CMOS IC
- Monolithic design with mixed mode signal processing
- RoHS compliant
- On-chip sensitivity compensation for temperature variations
- On Demand Self Test
- ± 5g dynamic range, 250mV/g sensitivity
- Independent axis programmability (special order)
- Resolution better than 1mg
- Zero-g Output Temperature drift, better than ±80mg over -40-95degC range
- 27Hz bandwidth
- >50,000 g shock survival rating
- 4.50V to 5.25V single supply operation
- Small surface mount package, 5mm x 5mm x 2mm
- Improved thermal gradient performance

APPLICATION

Automotive – Roll over sensing, VSC/EPB application

GENERAL DESCRIPTION

The MXR7305VF is a low cost, dual axis accelerometer built on a standard, submicron CMOS process. It measures acceleration with a full-scale range of ±5g and a sensitivity of 250mV/g.

The MXR7305VF provides a g-proportional ratiometric analog output above/below the zero-g point at 50% of the supply voltage.

(Ref. other MEMSIC data sheets for absolute analog or digital outputs).

The typical noise floor is $0.6\text{mg} / \sqrt{\text{Hz}}$, allowing signals below 1mg to be resolved at 1Hz bandwidth. The 3dB roll-off of the device occurs at 27Hz.

The MXR7305V is available in a low profile LCC surface mount package (5mm x 5mm 2mm). It is hermetically sealed and operational over a -40°C to +95°C temperature range.

Information furnished by MEMSIC is believed to be accurate and reliable. However, no responsibility is assumed by MEMSIC for its use, nor for any infringements of patents or other rights of third parties, which may result from its use. No license is granted by implication or otherwise under any patent or patent rights of MEMSIC.

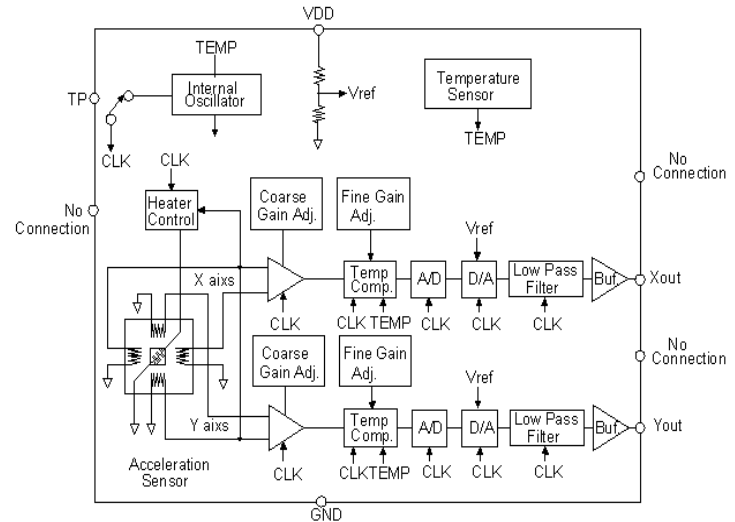

MXR7305V FUNCTIONAL BLOCK DIAGRAM

Memsic’s accelerometer technology allows for designs from ±1 g to ±70 g with custom versions available above ±70 g. It can measure both dynamic acceleration (e.g., vibration) and static acceleration (e.g., gravity). The design is based on heat convection and requires no solid proof mass. This eliminates stiction and particle problems associated with competitive devices and provide shock survival greater than 50,000 g, leading to significantly lower failure rates and lower loss due to handling during assembly and at customer field application. Due to the standard CMOS structure of the MXR7305V, additional circuitry can easily be incorporated into custom versions for high volume applications. Contact Memsic’s local office for more information.

©MEMSIC, Inc.
One Technology Drive, Suite 325, Andover, MA01810, USA
Tel: +1 978 738 0900 Fax: +1 978 738 0196
www.memsic.com

MXR7305VF SPECIFICATIONS (Measurements @ 25°C, Acceleration = 0 g unless otherwise noted; V_{DD} = 5.0V unless otherwise specified)

Parameter	Conditions	MXR7305V			Units
		Min	Typ	Max	
SENSOR INPUT	Each Axis				
Measurement Range ¹		±5.0			g
No linearity	Best fit straight line		0.5	1.0	% of FS
Alignment Error ²	±1g input range, least squares fit		±0.2	20	mg
Transverse Sensitivity ³			±0.5	±2.0	%
SENSITIVITY	Each Axis				
Sensitivity, Analog Outputs at pins Xout and Yout ⁴	@5.0V supply	235	250	265	mV/g
Sensitivity Ratiometricity	5V+/-5%		1.0	2.0	%
Change over Temperature ⁶	Δ from 25°C -40°C to +95°C	-6		+3	%
Change over Temperature with 2 nd Temp Comp ⁶		-3		+3	%
Change over Temperature with aging		-6		+4	%
Change over Temperature with 2 nd Temp Comp and aging ^{6,8}		-4		+4	%
ZERO g BIAS LEVEL	Each Axis				
0 g Offset		-0.20	0.00	+0.20	g
0 g Voltage		2.45	2.5	2.55	V
0 g Offset Ratiometricity	5V+/-5%			1.0	%
0 g Offset over Temperature	Δ from 25°C, based on 250mV/g	-80		80	mg
	With 2 nd Temp Comp	-40		40	mg
0g Offset over Temp with aging ⁶	Δ from 25°C, based on 250mV/g	-120		120	mg
	With 2 nd Temp Comp	-80		80	mg
0g Δ Offset over Temp ^{6,7}	max-min from -20°C to +80°C	0		60	mg
	max-min from 0°C to 60°C	0		50	mg
NOISE PERFORMANCE	-40°C to +95°C		0.6	1.5	mg/√Hz
Noise Density, rms					
FREQUENCY RESPONSE					
3dB Bandwidth		24	27	30	Hz
Phase delay	at 5Hz		-18		deg
SELF TEST					
Delta Output changes at Xout, Yout	at 25°C, 0g input	-650	-830	-1000	mV
	at 25°C, 1g input	-700	-850	-1050	mV
	at 25°C, -1g input	-600	-900	-1100	mV
	-40°C~95°C, 0g input	-600		-1100	mV
	-40°C~95°C, 1g input	-500		-1500	mV
	-40°C~95°C, -1g input	-600		-1600	mV
Selftest Input Voltage	High	4.0			V
	Low			1.0	V
Selftest Response Time		20	25	30	mS
Self Test Pin Pull-Down Resistor (Internal)			50		Kohms
Xout and Yout OUTPUTS					
Normal Output Range		0.5		4.5	V
(Guaranteed symmetric clipping)					
Current	Source or sink, @ 4.5V-5.25V supply			100	μA
Resistance				100	ohm
Capacitance				100	pF
Turn-On Time	@5.0V Supply		80	200	mS
POWER SUPPLY					
Operating Voltage Range		4.5	5.0	5.25	V
Supply Current ⁵	@ 5.0V RMS	3.2	4.1	5.0	mA
TEMPERATURE RANGE					
Operating Range		-40		+95	°C
PRESSURE RANGE					
Operating Range		40		300	KPa.

NOTES

- ¹ Guaranteed by measurement of initial offset and sensitivity.
- ² Alignment error is specified as the angle between the true and indicated axis of sensitivity.
- ³ Transverse sensitivity is the algebraic sum of the alignment and the inherent sensitivity errors.
- ⁴ The device operates over a 4.5V to 5.25V supply range. The output zero g reference voltage scales 50% of the supply voltage. Sensitivity has a linear scale over the supply range of 4.5 to 5.25 volts according to the ratio (V_{DD}/5.0 volts) x (250mV/g).
recommended to filter with a minimum of 200Hz low pass filter.
- ⁵ Note that the accelerometer has a constant heater power control circuit thereby requiring higher supply current at lower operating voltage
- ⁶ Based on characterization data of 3lotsx30 parts per lot
- ⁷ Calculated by MAX-MIN
- ⁸ Pending for qualification data

ABSOLUTE MAXIMUM RATINGS*

Supply Voltage (V_{DD}, V_{DA})¹-0.5 to +7.0V
 Storage Temperature-70°C to +150°C
 Storage Pressure.....1,378 kPa
 Acceleration (any axis, Un-powered for 0.5 msec)...50,000 g
 Output Short Circuit Duration, any pin to common.....Indefinite

*Stresses above those listed under Absolute Maximum Ratings may cause permanent damage to the device. This is a stress rating only; the functional operation of the device at these or any other conditions above those indicated in the operational sections of this specification is not implied. Exposure to absolute maximum rating conditions for extended periods may affect device reliability.

¹ Exposure for up to 60 minutes to absolute maximum ratings for supply voltages will not affect device reliability.

Package Characteristics

Package	θ _{JA}	θ _{JC}	Device Weight
LCC-8	110°C/W	22°C/W	< 1 gram

Ordering Guide

Model	Package Style
MXR7305VF	LCC-8 SMD*

* Parts are shipped in tape and reel packaging.

Caution

ESD (electrostatic discharge) sensitive device.

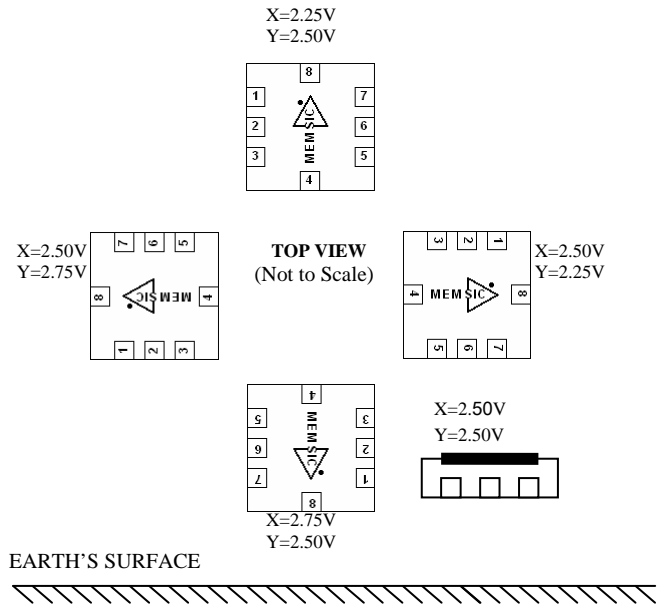

Note: The MEMSIC logo's arrow indicates the -X sensing direction of the device.
 The +Y sensing direction is rotated 90° away from the +X direction.
 Small circle indicates pin one (1).

Pin Description: LCC-8 Package

Pin	Name	Description
1	STIN	Self -Test Input
2	CLK	To be grounded. (Optional Serial Clock Input)
3	COM	Ground
4	NC	No Connect
5	NC	No Connect
6	YOUT	Y-Channel Ratiometric Output
7	XOUT	X-Channel Ratiometric Output
8	V _{DD}	Supply Voltage 4.5 to 5.25 V

ESD Compliance:

The MXR7305V sensor is in compliance with the following ESD standards:

- Human Body and 2500V per AEC-Q100-002 Rev. E
- Machine Model and 250V per AEC-Q100-003 Rev. E

Mounting Orientation:

The package orientation of the MXR7305V does not affect the performance of the sensor. The specifications as stated in page 2 remain the same.

Thus, if the sensor is installed with one of its axis of sensitivity in the vertical plane, it detects accelerations in the Z-axis.

THEORY OF OPERATION

The MEMSIC device is a complete dual-axis acceleration measurement system fabricated on a monolithic CMOS IC process. The device operation is based on heat transfer by natural convection and operates like other accelerometers having a proof mass except it is a gas in the MEMSIC sensor.

A single heat source, centered in the silicon chip is suspended across a cavity. Equally spaced aluminum/polysilicon thermopiles (groups of thermocouples) are located equidistantly on all four sides of the heat source (dual axis). Under zero acceleration, a temperature gradient is symmetrical about the heat source, so that the temperature is the same at all four thermopiles, causing them to output the same voltage.

Acceleration in any direction will disturb the temperature profile, due to free convection heat transfer, causing it to be asymmetrical. The temperature, and hence voltage output of the four thermopiles will then be different. The differential voltage at the thermopile outputs is directly proportional to the acceleration. There are two identical acceleration signal paths on the MXR7305V, one to measure acceleration in the x-axis and one to measure acceleration in the Y-axis. For more details visit the MEMSIC website at www.memsic.com for a picture/graphic description of the free convection heat transfer principle.

PIN DESCRIPTIONS

V_{DD} – (pin 8). Supply voltage input for digital and analog circuits.

For proper operation **V_{DD}** must be between 4.50 and 5.25 volts. Refer to the section on PCB layout and fabrication suggestions for guidance on external parts and connections recommended.

X_{OUT} – (pin 7). X-axis acceleration signal output. It is capable of sinking or sourcing up to 100 μ A. The user should ensure the load impedance is sufficiently high as to not source/sink >100 μ A. While the sensitivity of this axis has been programmed at the factory to be the same as the sensitivity for the Y-axis, the MXR7305V can be programmed for non-equal sensitivities on the x- and y-axes.

Contact Memsic's local office for additional information.

Y_{OUT} – (pin 6) Y-axis acceleration signal output.

It is capable of sinking or sourcing up to 100 μ A. The user should ensure the load impedance is sufficiently high as to not source/sink >100 μ A. While the sensitivity of this axis has been programmed at the factory to be the same as the sensitivity for the X-axis, the MXR7305V can be programmed for non-equal sensitivities on the X- and Y-axes.

Contact Memsic's local office for additional information.

NC – (pin 5, 4) No connect. These pins can be tied to common if the application does not allow pins to remain unconnected.

COM – (pin 3) This is the ground pin for the MXR7305V

CLK – (pin 2) This is an optional serial clock input. The standard product is delivered with an internal clock (1000 kHz). However, an external clock between 400 kHz and 1.6 MHz can be used as an option, if the sensor is programmed from the factory to run in external clock mode. This pin is grounded internally with a 50 Kohm resistor if an external clock is used it should be able to drive this load. But if external clock is not used, in order to minimize noise and ESD this pin should be grounded externally as well.

ST_{IN} – (pin 1) Self –Test Input

This pin controls the self-test function of the sensor.

Bringing ST_{IN} high will cause a negative deflection around 830mV to the X_{out} and Y_{out} from the 0g value.

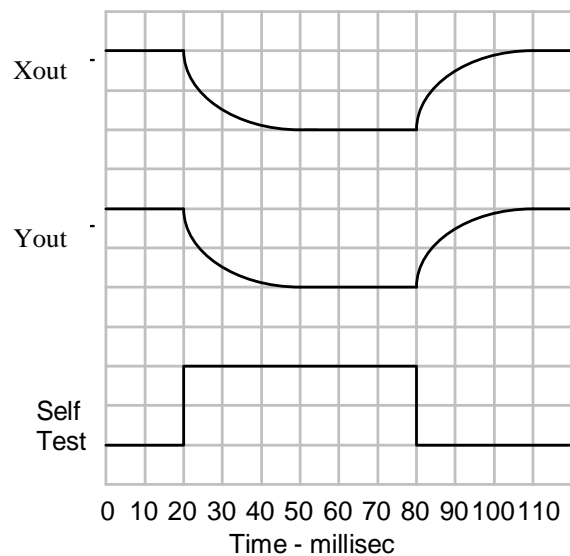

SELF-TEST DESCRIPTION

When Self-test is enabled the sensitivity compensation is turned off (disabled). With the sensitivity compensation disabled, the sensitivity will change according to the equation below:

$$S_i \times T_i^{2.8} = k \times S_f \times T_f^{2.8}$$

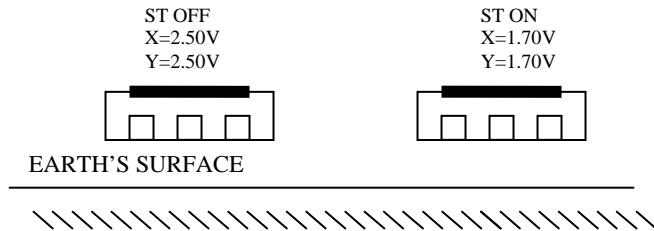

where S_i is the sensitivity at any initial temperature T_i , and S_f is the sensitivity at any other final temperature T_f with the temperature values in °C, k is the ratio between uncompensated sensitivity and compensated sensitivity at 25°C.

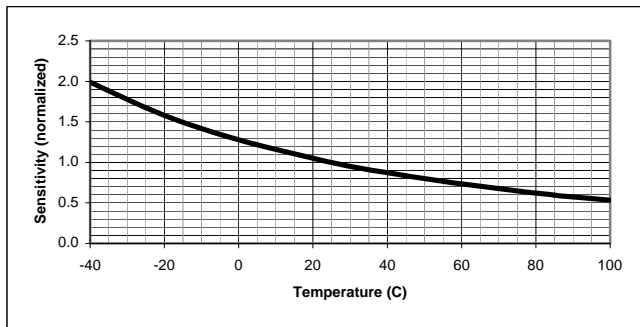

Thermal Accelerometer Sensitivity

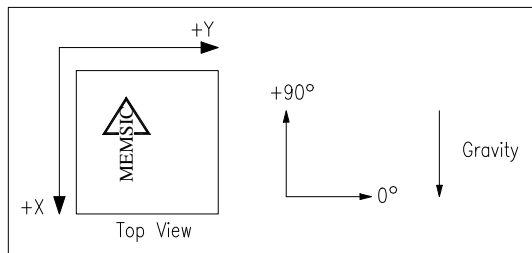

Accelerometer Position Relative to Gravity

Note1: When the temperature compensation is disabled and self-test is enabled. Self-test follows different gas law from sensitivity temperature dependence. It changes much smaller than sensitivity; this is why the temperature compensation is not done on self-test conditions.

Note2: Initial offset monitoring is a much better and reliable method to ensure sensor integrity, since it is ultra

sensitive to sensor structure defect and damage. As long as initial offset is within specification the sensor is functioning correctly.

The sensor structure for the Thermal technology is guaranteed to fall outside the specified initial zero g offset parameters if the sensor is damaged or thermopile is failing. In most cases this will result in the output voltage hitting the rail at 5.0 volts.

PCB LAYOUT AND FABRICATION SUGGESTIONS

Reference figure and the notes below for recommendations on connecting a power source to the MEMSIC device and PCB fabrication.

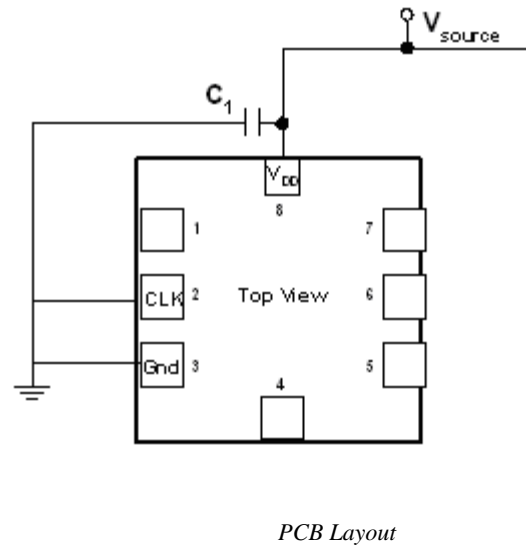

Notes:

1. $C_1 = 1.0\mu\text{F}$
2. The capacitor should be located as close as possible to the device supply pin V_{DD} , since the internal heater is in PWM (1MHz) control mode, with all V_{DD} on the heater at some portion of the time, by using larger value capacitor can minimize the induced noise on the outputs.
3. The CLK is grounded internally with a 50 kOhm resistor, however, in order to minimize noise and ESD this pin should be grounded externally as well.
4. Robust low inductance ground wiring should be used.
5. Care should be taken (like isolated rings and planes, signal route out perpendicular to the external thermal gradient) to ensure there is “thermal symmetry” on the PCB immediately surrounding the MEMSIC device and that there is no significant heat source nearby since it may cause a temperature gradient (“thermal gradient”) across MEMSIC device, thus result in performance change (additional initial offset and offset drift).

MECHANICAL PACKAGE OUTLINE DIMENSIONS

Dimensions shown in mm.

LCC-8, Eight Pin, Hermetically Sealed, Surface Mount Package

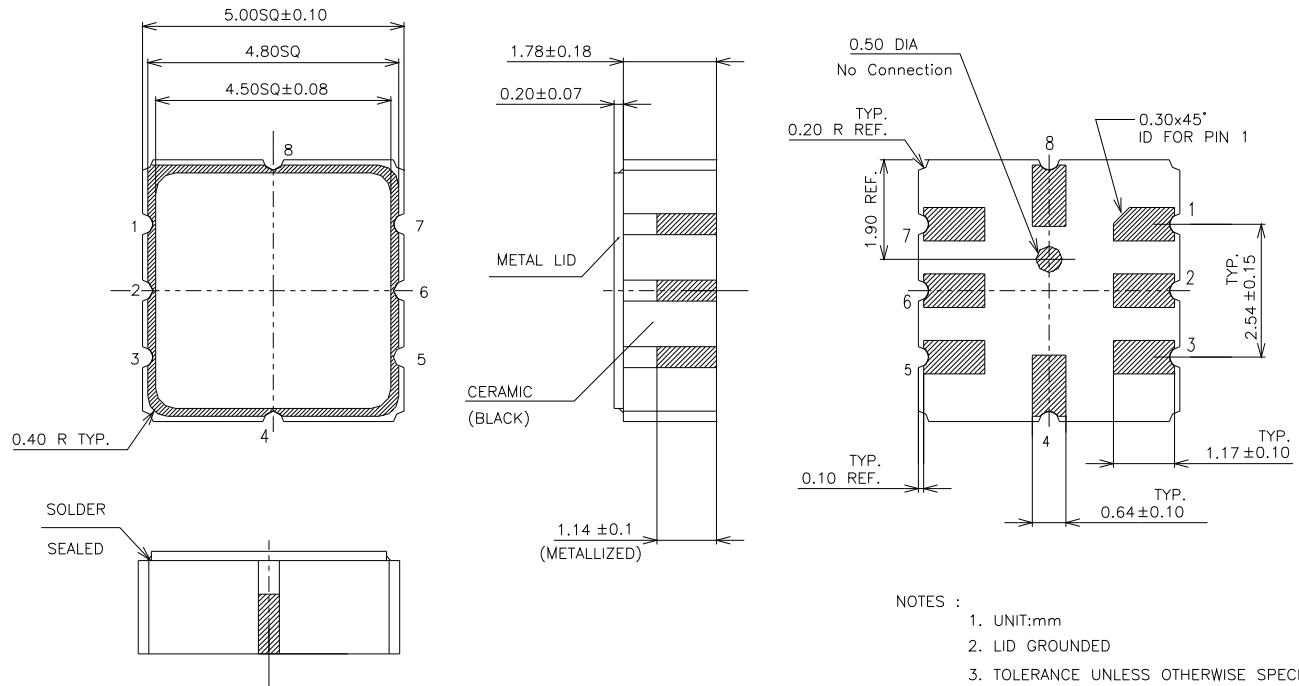

- NOTES :
1. UNIT:mm
 2. LID GROUNDED
 3. TOLERANCE UNLESS OTHERWISE SPECIFIED WITHIN +/-0.20

Mouser Electronics

Authorized Distributor

Click to View Pricing, Inventory, Delivery & Lifecycle Information:

[MEMSIC:](#)

[MXR7305VF](#)