

LM2677 SIMPLE SWITCHER® High Efficiency 5-A Step-Down Voltage Regulator with Sync

1 Features

- Efficiency up to 92%
- Simple and Easy to Design Using Off-the-Shelf External Components
- 100-mΩ DMOS Output Switch
- 3.3-V, 5-V, and 12-V Fixed Output and Adjustable (1.2 V to 37 V) Versions
- 50-μA Standby Current When Switched OFF
- ±2% Maximum Output Tolerance Over Full Line and Load Conditions
- Wide Input Voltage Range: 8 V to 40 V
- External Sync Clock Capability (280 kHz to 400 kHz)
- 260-kHz Fixed Frequency Internal Oscillator
- -40°C to 125°C Operating Junction Temperature Range

2 Applications

- Simple to Design, High Efficiency (> 90%) Step-Down Switching Regulators
- Efficient System Preregulator for Linear Voltage Regulators
- Battery Chargers
- Communications and Radio Equipment Regulator With Synchronized Clock Frequency

3 Description

The LM2677 series of regulators are monolithic integrated circuits which provide all of the active functions for a step-down (buck) switching regulator capable of driving up to 5-A loads with excellent line and load regulation characteristics. High efficiency (>90%) is obtained through the use of a low on-resistance DMOS power switch. The series consists of fixed output voltages of 3.3-V, 5-V, and 12-V and an adjustable output version.

The SIMPLE SWITCHER® concept provides for a complete design using a minimum number of external components. The switching clock frequency can be provided by an internal fixed frequency oscillator (260 kHz) or from an externally provided clock in the range of 280 kHz to 400 kHz, which allows the use of physically smaller-sized components. A family of standard inductors for use with the LM2677 are available from several manufacturers to greatly simplify the design process. The external Sync clock provides direct and precise control of the output ripple frequency for consistent filtering or frequency spectrum positioning.

The LM2677 series also has built-in thermal shutdown, current-limiting, and an ON/OFF control input that can power down the regulator to a low 50-μA quiescent-current standby condition. The output voltage is ensured to a ±2% tolerance.

Device Information⁽¹⁾

PART NUMBER	PACKAGE	BODY SIZE (NOM)
LM2677	TO-263 (7)	10.16 mm × 8.69 mm
	TO-220 (7)	10.16 mm × 8.94 mm
	VSON (14)	6.10 mm × 5.10 mm

(1) For all available packages, see the orderable addendum at the end of the data sheet.

Typical Application

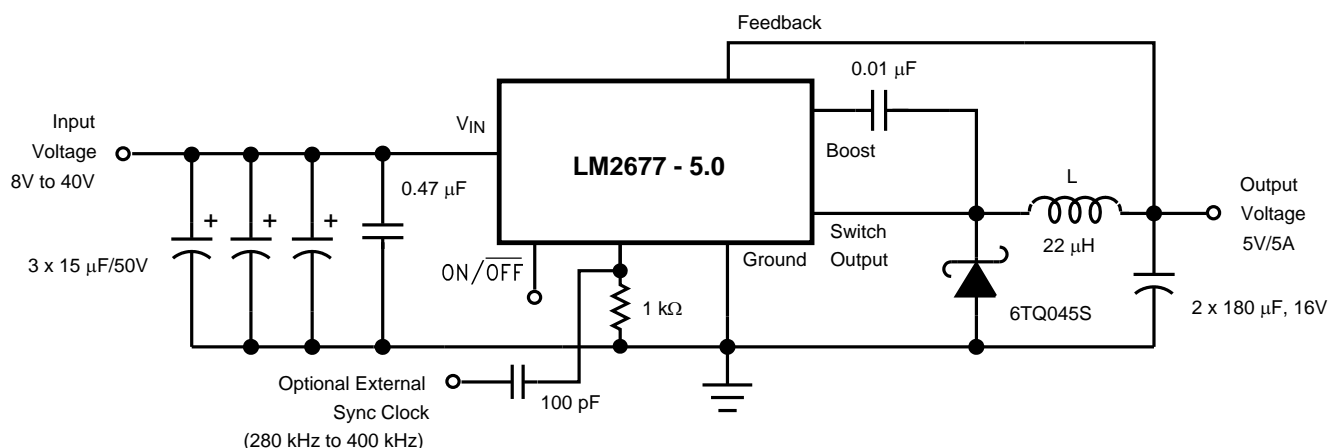

Copyright © 2016, Texas Instruments Incorporated



Table of Contents

1 Features	1	7.2 Functional Block Diagram	10
2 Applications	1	7.3 Feature Description	10
3 Description	1	7.4 Device Functional Modes	11
4 Revision History	2	8 Application and Implementation	12
5 Pin Configuration and Functions	3	8.1 Application Information	12
6 Specifications	4	8.2 Typical Application	16
6.1 Absolute Maximum Ratings	4	9 Power Supply Recommendations	25
6.2 ESD Ratings	4	10 Layout	25
6.3 Recommended Operating Conditions	4	10.1 Layout Guidelines	25
6.4 Thermal Information	5	10.2 Layout Example	26
6.5 Electrical Characteristics – 3.3 V	5	11 Device and Documentation Support	27
6.6 Electrical Characteristics – 5 V	5	11.1 Documentation Support	27
6.7 Electrical Characteristics – 12 V	6	11.2 Receiving Notification of Documentation Updates	27
6.8 Electrical Characteristics – Adjustable	6	11.3 Community Resources	27
6.9 Electrical Characteristics – All Output Voltage Versions	6	11.4 Trademarks	27
6.10 Typical Characteristics	7	11.5 Electrostatic Discharge Caution	27
7 Detailed Description	10	11.6 Glossary	27
7.1 Overview	10	12 Mechanical, Packaging, and Orderable Information	27

4 Revision History

NOTE: Page numbers for previous revisions may differ from page numbers in the current version.

Changes from Revision I (June 2012) to Revision J

Page

- Added *ESD Ratings* table, *Feature Description* section, *Device Functional Modes*, *Application and Implementation* section, *Power Supply Recommendations* section, *Layout* section, *Device and Documentation Support* section, and *Mechanical, Packaging, and Orderable Information* section
- Deleted Manufacturers' Contact Numbers tables

5 Pin Configuration and Functions

**KTW Package
7-Pin TO-263
Top View**

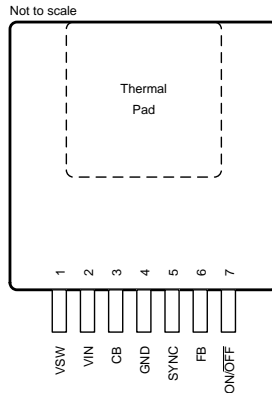

**NDZ Package
7-Pin TO-220
Top View**

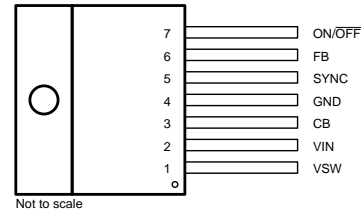

**NHM Package
14-Pin VSON
Top View**

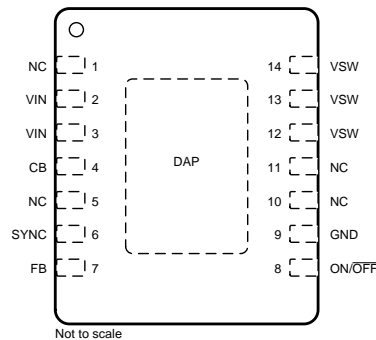

Pin Functions

NAME	PIN		I/O	DESCRIPTION
	TO-263, TO-220	VSON		
CB	3	4	I	Boot-strap capacitor connection for high-side driver. Connect a high quality 100-nF capacitor from CB to V _{SW} pin.
FB	6	7	I	Feedback sense input pin. Connect to the midpoint of feedback divider to set V _{OUT} for ADJ version or connect this pin directly to the output capacitor for a fixed output version.
GND	4	9	—	Power ground pins. Connect to system ground. Ground pins of C _{IN} and C _{OUT} . Path to C _{IN} must be as short as possible.
NC	—	1, 5, 10, 11	—	No connect pins
ON/OFF	7	8	I	Enable input to the voltage regulator. High = ON and low = OFF. Pull this pin high or float to enable the regulator.
SYNC	5	6	I	This input allows control of the switching clock frequency. If left open-circuited the regulator is switched at the internal oscillator frequency, typically 260 kHz.
V _{IN}	2	2, 3	I	Supply input pin to collector pin of high side FET. Connect to power supply and input bypass capacitors C _{IN} . Path from V _{IN} pin to high frequency bypass C _{IN} and GND must be as short as possible.
V _{SW}	1	12, 13, 14	O	Source pin of the internal High Side FET. This is a switching node. Attached this pin to an inductor and the cathode of the external diode.

6 Specifications

6.1 Absolute Maximum Ratings

over recommended operating junction temperature range of -40°C to 125°C (unless otherwise noted)⁽¹⁾⁽²⁾

		MIN	MAX	UNIT
Input supply voltage			45	V
ON/OFF pin voltage		-0.1	6	V
Switch voltage to ground ⁽³⁾		-1	V_{IN}	V
Boost pin voltage			$V_{\text{SW}} + 8$	V
Feedback pin voltage		-0.3	14	V
Power dissipation		Internally limited		
Soldering temperature	Wave (4 s)		260	°C
	Infrared (10 s)		240	
	Vapor phase (75 s)		219	
Storage temperature, T_{stg}		-65	150	°C

- (1) Stresses beyond those listed under *Absolute Maximum Ratings* may cause permanent damage to the device. These are stress ratings only, which do not imply functional operation of the device at these or any other conditions beyond those indicated under *Recommended Operating Conditions*. Exposure to absolute-maximum-rated conditions for extended periods may affect device reliability.
- (2) If Military/Aerospace specified devices are required, please contact the Texas Instruments Sales Office/ Distributors for availability and specifications.
- (3) The switch voltage to ground specification applies to DC voltage. An extended negative voltage limit of -10 V applies to a pulse of up to 20 ns, -6 V of 60 ns, and -3 V of up to 100 ns.

6.2 ESD Ratings

			VALUE	UNIT
$V_{\text{(ESD)}}$	Electrostatic discharge	Human-body model (HBM), per ANSI/ESDA/JEDEC JS-001 ⁽¹⁾⁽²⁾	± 2000	V

- (1) JEDEC document JEP155 states that 500-V HBM allows safe manufacturing with a standard ESD control process.
- (2) ESD was applied using the human-body model, a 100-pF capacitor discharged through a 1.5-k Ω resistor into each pin.

6.3 Recommended Operating Conditions

over operating free-air temperature range (unless otherwise noted)

		MIN	MAX	UNIT
	Supply voltage	8	40	V
T_{J}	Junction temperature	-40	125	°C

6.4 Thermal Information

THERMAL METRIC ⁽¹⁾		LM2677			UNIT	
		KTW (TO-263)	NDZ (TO-220)	NHM (VSON)		
		7 PINS	7 PINS	14 PINS		
R _{θJA}	Junction-to-ambient thermal resistance	See ⁽²⁾	56	—	—	°C/W
		See ⁽³⁾	35	—	—	
		See ⁽⁴⁾	26	—	—	
		See ⁽⁵⁾	—	65	—	
		See ⁽⁶⁾	—	45	—	
		See ⁽⁷⁾	—	—	55	
		See ⁽⁸⁾	—	—	29	
R _{θJC(top)}	Junction-to-case (top) thermal resistance	2	2	—	°C/W	
R _{θJB}	Junction-to-board thermal resistance	—	—	—	°C/W	
ψ _{JT}	Junction-to-top characterization parameter	—	—	—	°C/W	
ψ _{JB}	Junction-to-board characterization parameter	—	—	—	°C/W	
R _{θJC(bot)}	Junction-to-case (bottom) thermal resistance	—	—	—	°C/W	

- (1) For more information about traditional and new thermal metrics, see the *Semiconductor and IC Package Thermal Metrics* application report.
- (2) Junction to ambient thermal resistance for the 7-pin DDPAK/TO-263 mounted horizontally against a PC board area of 0.136 square inches (the same size as the DDPAK/TO-263 package) of 1 oz. (0.0014 in. thick) copper.
- (3) Junction to ambient thermal resistance for the 7-pin DDPAK/TO-263 mounted horizontally against a PC board area of 0.4896 square inches (3.6 times the area of the DDPAK/TO-263 package) of 1 oz. (0.0014 in. thick) copper.
- (4) Junction to ambient thermal resistance for the 7-pin DDPAK/TO-263 mounted horizontally against a PC board copper area of 1.0064 square inches (7.4 times the area of the DDPAK/TO-263 package) of 1 oz. (0.0014 in. thick) copper. Additional copper area reduces thermal resistance further.
- (5) Junction to ambient thermal resistance (no external heat sink) for the 7-pin TO-220 package mounted vertically, with ½ inch leads in a socket, or on a PC board with minimum copper area.
- (6) Junction to ambient thermal resistance (no external heat sink) for the 7-pin TO-220 package mounted vertically, with ½ inch leads soldered to a PC board containing approximately 4 square inches of (1 oz.) copper area surrounding the pins.
- (7) Junction to ambient thermal resistance for the 14-pin VSON mounted on a PC board copper area equal to the die attach paddle.
- (8) Junction to ambient thermal resistance for the 14-lead VSON mounted on a PC board copper area using 12 vias to a second layer of copper equal to die attach paddle. Additional copper area reduces thermal resistance further. For layout recommendations, refer to Application Note, *AN-1187 Leadless Leadframe Package (LLP)*.

6.5 Electrical Characteristics – 3.3 V

T_J = 25°C, sync pin open circuited (unless otherwise noted)

PARAMETER	TEST CONDITIONS	MIN ⁽¹⁾	TYP ⁽²⁾	MAX ⁽¹⁾	UNIT	
V _{OUT} Output voltage	V _{IN} = 8 V to 40 V, 100 mA ≤ I _{OUT} ≤ 5 A	T _J = 25°C	3.234	3.3	3.366	V
		T _J = –40°C to 125°C	3.201		3.399	
η Efficiency	V _{IN} = 12 V, I _{LOAD} = 5 A		82%			

- (1) All limits are ensured at room temperature and at temperature extremes. All room temperature limits are 100% tested during production with T_A = T_J = 25°C. All limits at temperature extremes are ensured through correlation using standard standard Quality Control (SQC) methods. All limits are used to calculate Average Outgoing Quality Level (AOQL).
- (2) Typical values are determined with T_A = T_J = 25°C and represent the most likely norm.

6.6 Electrical Characteristics – 5 V

T_J = 25°C, sync pin open circuited (unless otherwise noted)

PARAMETER	TEST CONDITIONS	MIN ⁽¹⁾	TYP ⁽²⁾	MAX ⁽¹⁾	UNIT	
V _{OUT} Output voltage	V _{IN} = 8 V to 40 V, 100 mA ≤ I _{OUT} ≤ 5 A	T _J = 25°C	4.9	5	5.1	V
		T _J = –40°C to 125°C	4.85		5.15	
η Efficiency	V _{IN} = 12 V, I _{LOAD} = 5 A		84%			

- (1) All limits are ensured at room temperature and at temperature extremes. All room temperature limits are 100% tested during production with T_A = T_J = 25°C. All limits at temperature extremes are ensured through correlation using standard standard Quality Control (SQC) methods. All limits are used to calculate Average Outgoing Quality Level (AOQL).
- (2) Typical values are determined with T_A = T_J = 25°C and represent the most likely norm.

6.7 Electrical Characteristics – 12 V

 $T_J = 25^\circ\text{C}$, sync pin open circuited (unless otherwise noted)

PARAMETER	TEST CONDITIONS	MIN ⁽¹⁾	TYP ⁽²⁾	MAX ⁽¹⁾	UNIT	
V_{OUT} Output voltage	$V_{IN} = 15\text{ V to }40\text{ V}$, $100\text{ mA} \leq I_{OUT} \leq 5\text{ A}$	$T_J = 25^\circ\text{C}$	11.76	12	12.24	V
		$T_J = -40^\circ\text{C to }125^\circ\text{C}$	11.64		12.36	
η Efficiency	$V_{IN} = 24\text{ V}$, $I_{LOAD} = 5\text{ A}$		92%			

- (1) All limits are ensured at room temperature and at temperature extremes. All room temperature limits are 100% tested during production with $T_A = T_J = 25^\circ\text{C}$. All limits at temperature extremes are ensured through correlation using standard standard Quality Control (SQC) methods. All limits are used to calculate Average Outgoing Quality Level (AOQL).
- (2) Typical values are determined with $T_A = T_J = 25^\circ\text{C}$ and represent the most likely norm.

6.8 Electrical Characteristics – Adjustable

 $T_J = 25^\circ\text{C}$, sync pin open circuited (unless otherwise noted)

PARAMETER	TEST CONDITIONS	MIN ⁽¹⁾	TYP ⁽²⁾	MAX ⁽¹⁾	UNIT	
V_{FB} Feedback voltage	$V_{IN} = 8\text{ V to }40\text{ V}$, $100\text{ mA} \leq I_{OUT} \leq 5\text{ A}$, V_{OUT} programmed for 5 V	$T_J = 25^\circ\text{C}$	1.186	1.21	1.234	V
		$T_J = -40^\circ\text{C to }125^\circ\text{C}$	1.174		1.246	
η Efficiency	$V_{IN} = 12\text{ V}$, $I_{LOAD} = 5\text{ A}$		84%			

- (1) All limits are ensured at room temperature and at temperature extremes. All room temperature limits are 100% tested during production with $T_A = T_J = 25^\circ\text{C}$. All limits at temperature extremes are ensured through correlation using standard standard Quality Control (SQC) methods. All limits are used to calculate Average Outgoing Quality Level (AOQL).
- (2) Typical values are determined with $T_A = T_J = 25^\circ\text{C}$ and represent the most likely norm.

6.9 Electrical Characteristics – All Output Voltage Versions

 $T_J = 25^\circ\text{C}$, $V_{IN} = 12\text{ V}$ for the 3.3-V, 5-V, and Adjustable versions, $V_{IN} = 24\text{ V}$ for the 12-V version, sync pin open circuited (unless otherwise noted)

PARAMETER	TEST CONDITIONS	MIN ⁽¹⁾	TYP ⁽²⁾	MAX ⁽¹⁾	UNIT	
I_Q Quiescent current	$V_{FEEDBACK} = 8\text{ V}$ for 3.3-V, 5-V, and adjustable versions, $V_{FEEDBACK} = 15\text{ V}$ for 12-V versions		4.2	6	mA	
I_{STBY} Standby quiescent current	ON/OFF pin = 0 V	$T_J = 25^\circ\text{C}$	50	100	μA	
		$T_J = -40^\circ\text{C to }125^\circ\text{C}$		150		
I_{CL} Current limit		$T_J = 25^\circ\text{C}$	6.1	7	8.3	A
		$T_J = -40^\circ\text{C to }125^\circ\text{C}$	5.75		8.75	
I_L Output leakage current	$V_{IN} = 40\text{ V}$, ON/OFF pin = 0 V		1	200	μA	
	$V_{SWITCH} = 0\text{ V}$			15		
	$V_{SWITCH} = -1\text{ V}$		6		mA	
$R_{DS(ON)}$ Switch on-resistance	$I_{SWITCH} = 5\text{ A}$	$T_J = 25^\circ\text{C}$	0.12	0.14	Ω	
		$T_J = -40^\circ\text{C to }125^\circ\text{C}$		0.225		
f_O Oscillator frequency	Measured at switch pin	$T_J = 25^\circ\text{C}$	260		kHz	
		$T_J = -40^\circ\text{C to }125^\circ\text{C}$	225	280		
D Duty cycle	Maximum duty cycle		91%			
	Minimum duty cycle		0%			
I_{BIAS} Feedback bias current	$V_{FEEDBACK} = 1.3\text{ V}$, ADJ version only		85		nA	
$V_{ON/OFF}$ ON/OFF threshold voltage		$T_J = 25^\circ\text{C}$	1.4		V	
		$T_J = -40^\circ\text{C to }125^\circ\text{C}$	0.8	2		
$I_{ON/OFF}$ ON/OFF input current	ON/OFF input = 0 V	$T_J = 25^\circ\text{C}$	20		μA	
		$T_J = -40^\circ\text{C to }125^\circ\text{C}$		45		
F_{SYNC} Synchronization frequency	$V_{SYNC}(\text{pin } 5) = 3.5\text{ V}$, 50% duty cycle		400		kHz	
V_{SYNC} SYNC threshold voltage			1.4		V	

- (1) All limits are ensured at room temperature and at temperature extremes. All room temperature limits are 100% tested during production with $T_A = T_J = 25^\circ\text{C}$. All limits at temperature extremes are ensured through correlation using standard standard Quality Control (SQC) methods. All limits are used to calculate Average Outgoing Quality Level (AOQL).
- (2) Typical values are determined with $T_A = T_J = 25^\circ\text{C}$ and represent the most likely norm.

6.10 Typical Characteristics

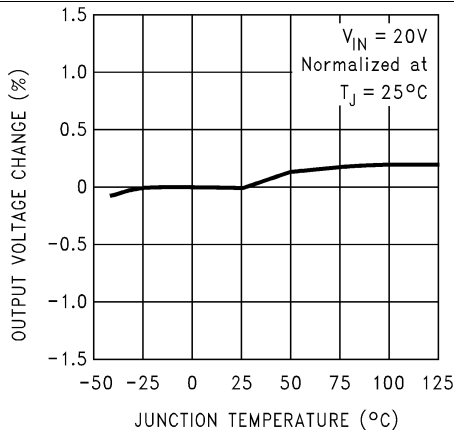

Figure 1. Normalized Output Voltage

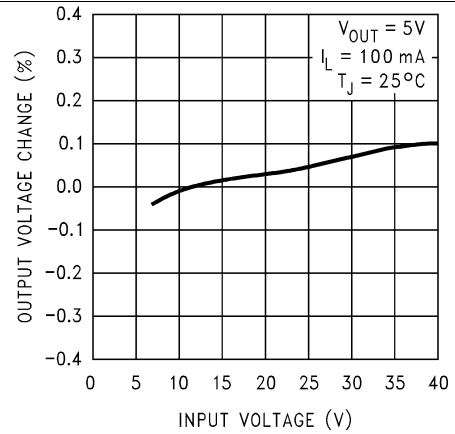

Figure 2. Line Regulation

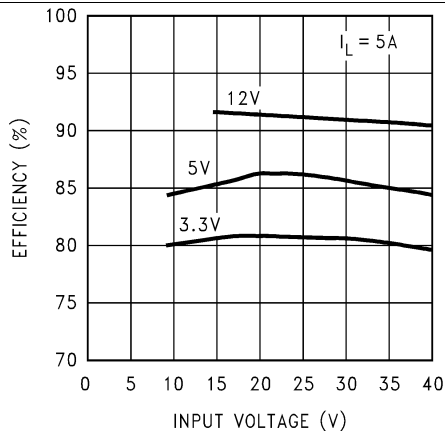

Figure 3. Efficiency vs Input Voltage

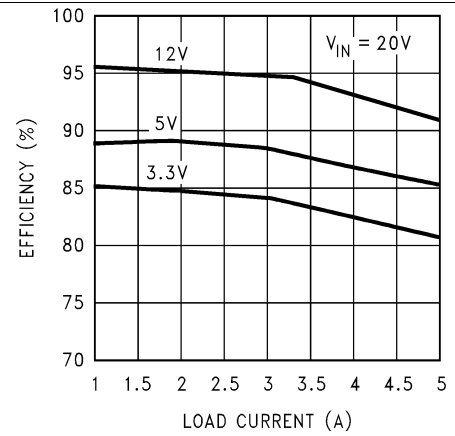

Figure 4. Efficiency vs I_{LOAD}

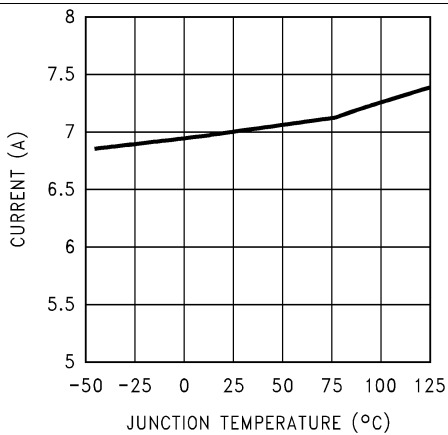

Figure 5. Switch Current Limit

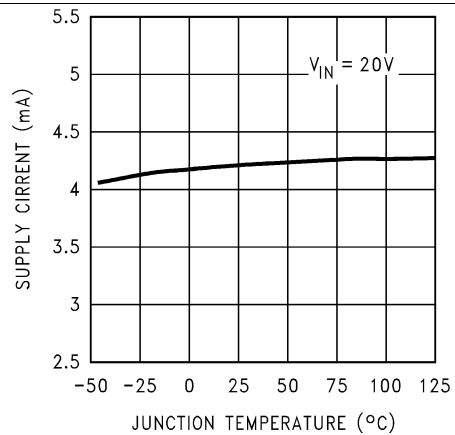

Figure 6. Operating Quiescent Current

Typical Characteristics (continued)

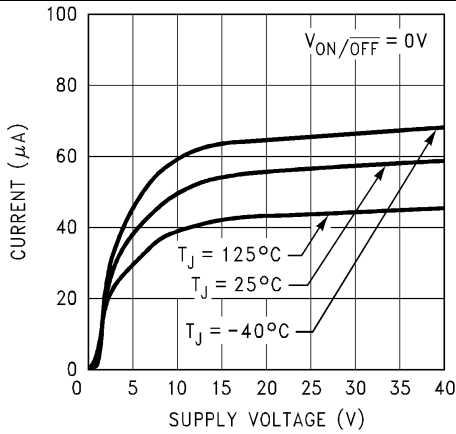

Figure 7. Standby Quiescent Current

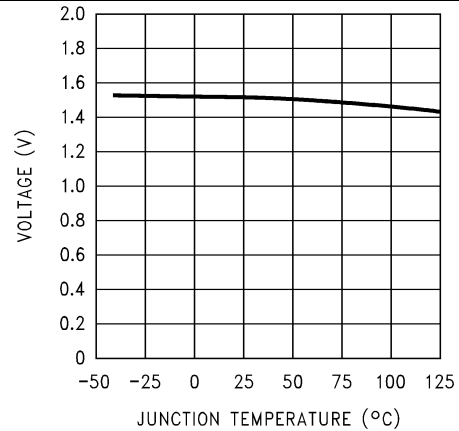

Figure 8. ON/OFF Threshold Voltage

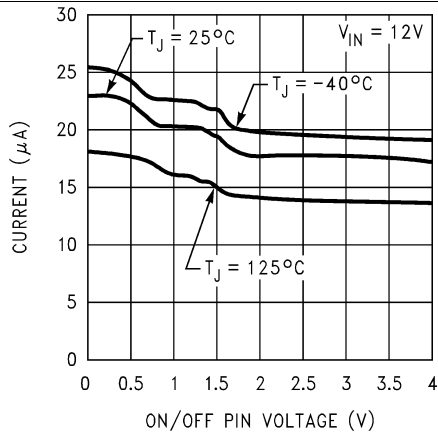

Figure 9. ON/OFF Pin Current (Sourcing)

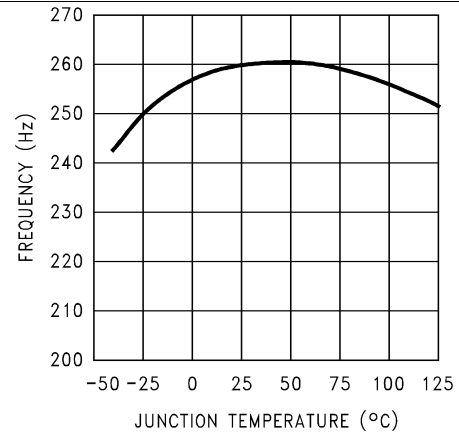

Figure 10. Switching Frequency

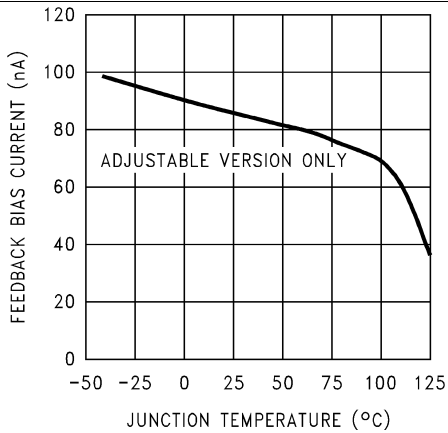
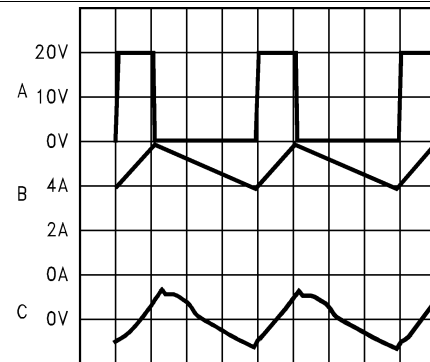

Figure 11. Feedback Pin Bias Current



1 μ sec/Div
 V_{SW} pin voltage, 10 V/div $V_{IN} = 20$ V, $V_{OUT} = 5$ V,
 Inductor current, 2 A/div $I_{LOAD} = 5$ A, $L = 10$ μ H,
 Output ripple voltage, $C_{OUT} = 400$ μ F,
 20 mV/div AC-coupled $C_{OUT}ESR = 13$ m Ω

Figure 12. Continuous Mode Switching Waveforms, Horizontal Time Base: 1 μ s/div

Typical Characteristics (continued)

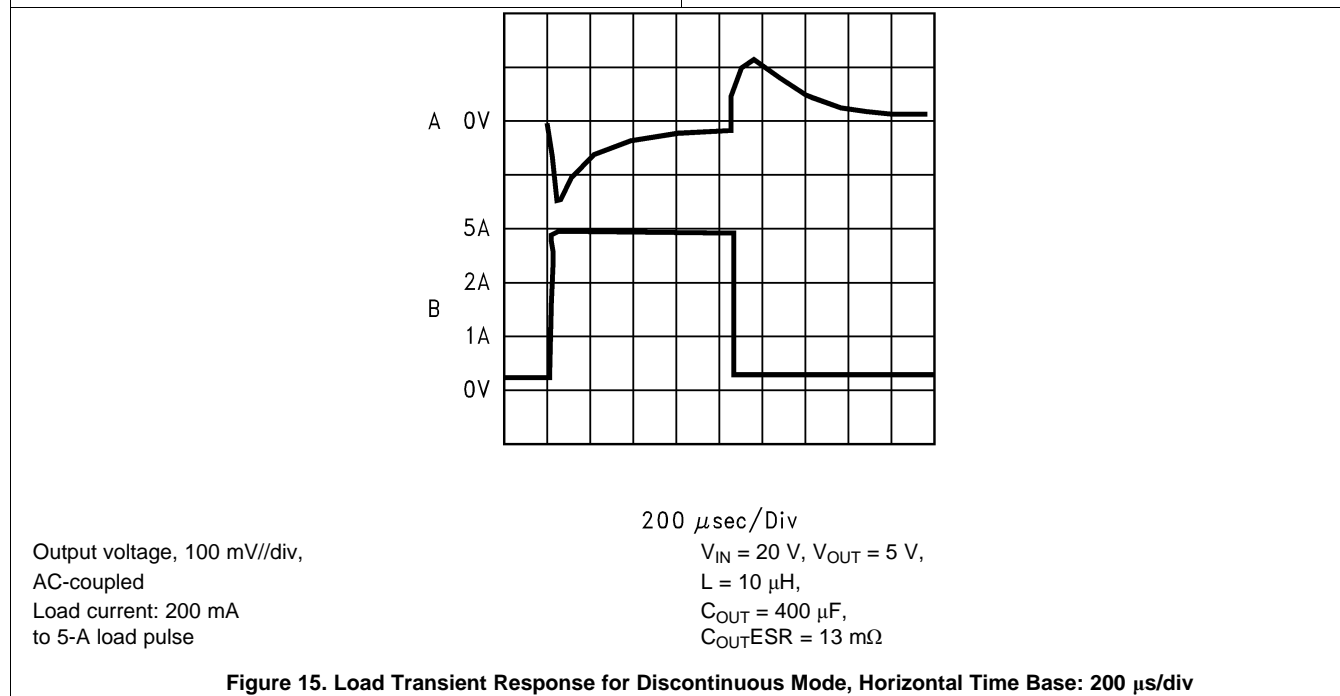
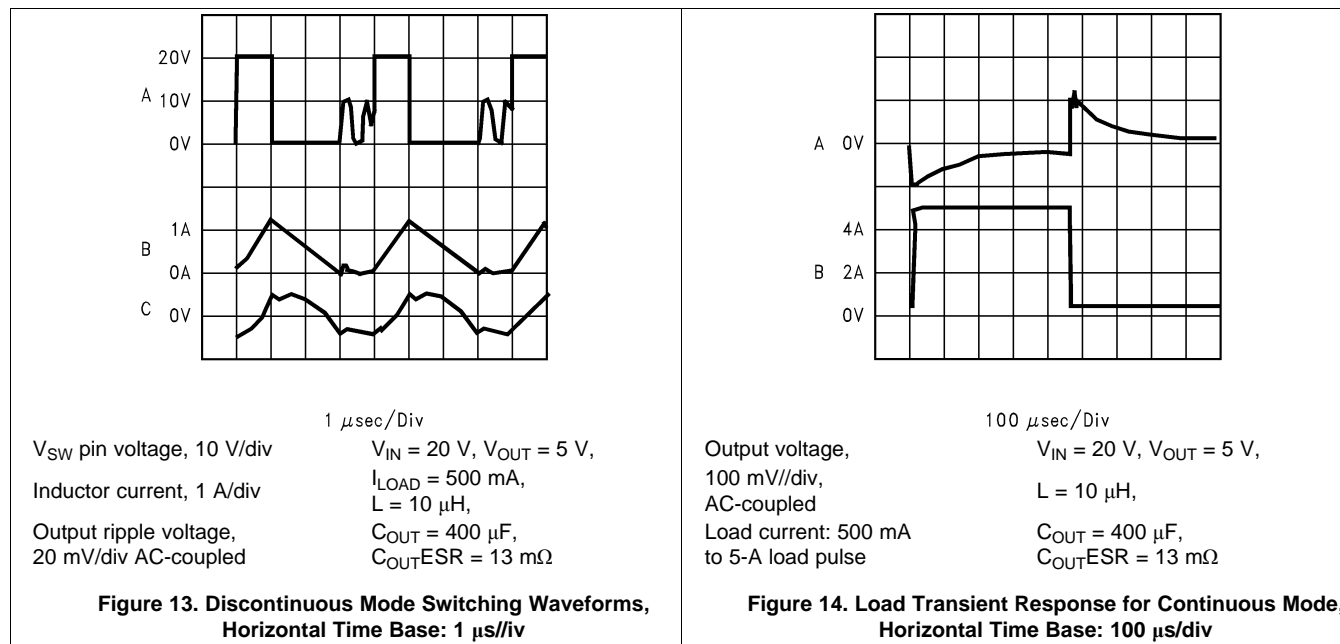

7 Detailed Description

7.1 Overview

The LM2677 provides all of the active functions required for a step-down (buck) switching regulator. The internal power switch is a DMOS power MOSFET to provide power supply designs with high current capability, up to 5 A, and highly efficient operation.

The LM2677 is part of the SIMPLE SWITCHER family of power converters. A complete design uses a minimum number of external components, which have been predetermined from a variety of manufacturers.

7.2 Functional Block Diagram

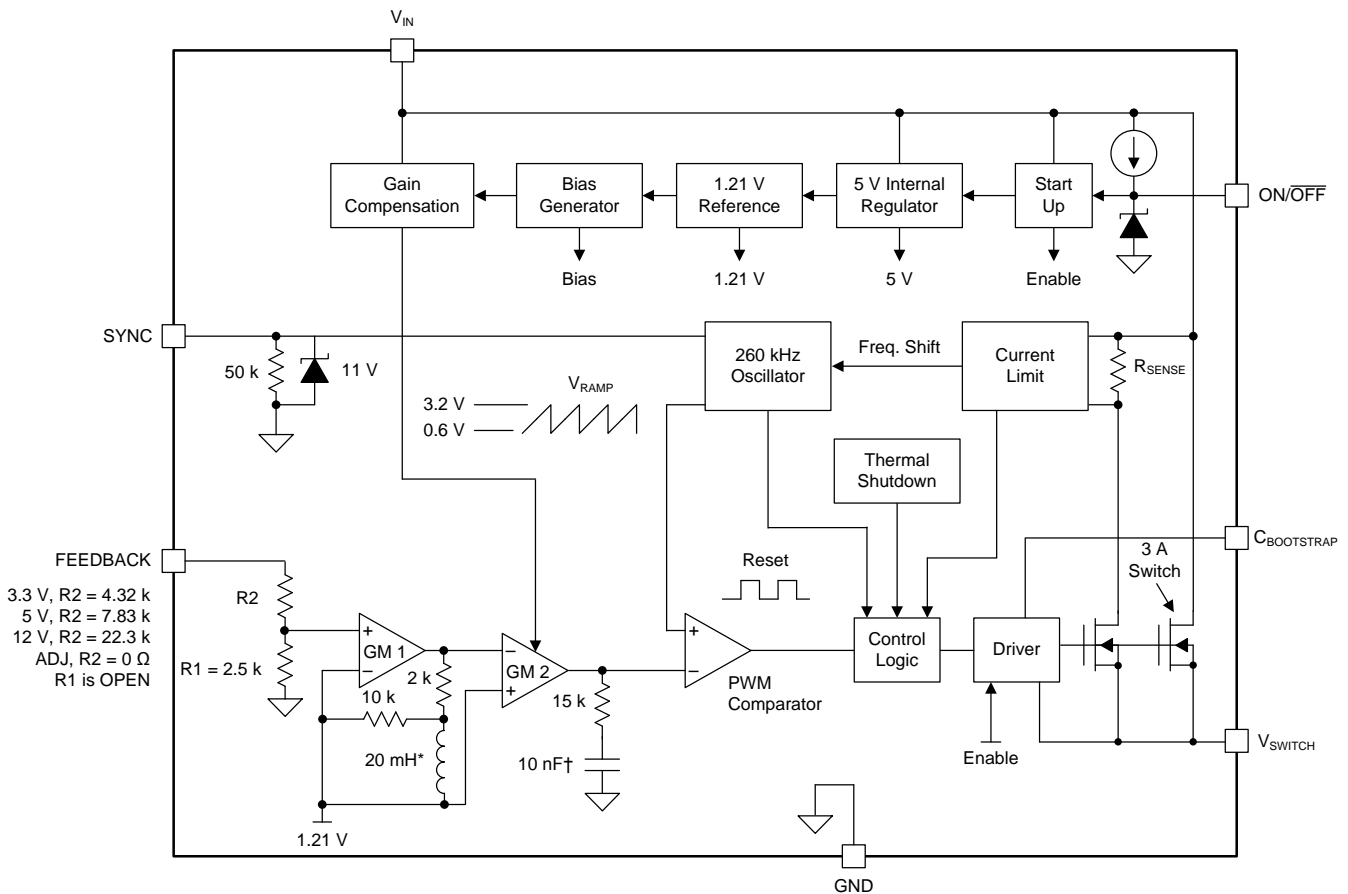

7.3 Feature Description

7.3.1 Switch Output

This is the output of a power MOSFET switch connected directly to the input voltage. The switch provides energy to an inductor, an output capacitor, and the load circuitry under control of an internal pulse-width-modulator (PWM). The PWM controller is internally clocked by a fixed 260-kHz oscillator. In a standard step-down application the duty cycle (Time ON/Time OFF) of the power switch is proportional to the ratio of the power supply output voltage to the input voltage. The voltage on pin 1 switches between V_{IN} (switch ON) and below ground by the voltage drop of the external Schottky diode (switch OFF).

Feature Description (continued)

7.3.2 CBoost

A capacitor must be connected from pin 3 to the switch output, pin 1. This capacitor boosts the gate driver to the internal MOSFET above V_{IN} to fully turn it ON. This minimizes conduction losses in the power switch to maintain high efficiency. The recommended value for CBoost is 0.01 μF .

7.3.3 Ground

This is the ground reference connection for all components in the power supply. In fast-switching, high-current applications such as those implemented with the LM2677, TI recommends using a broad ground plane to minimize signal coupling throughout the circuit.

7.3.4 Sync

This input allows control of the switching clock frequency. If left open-circuited the regulator is switched at the internal oscillator frequency, from 225 kHz to 280 kHz. An external clock can be used to force the switching frequency and thereby control the output ripple frequency of the regulator. This capability provides for consistent filtering of the output ripple from system to system as well as precise frequency spectrum positioning of the ripple frequency, which is often desired in communications and radio applications. This external frequency must be greater than the LM2677 internal oscillator frequency, which could be as high as 280 kHz, to prevent an erroneous reset of the internal ramp oscillator and PWM control of the power switch. The ramp oscillator is reset on the positive going edge of the sync input signal. TI recommends ac-coupling the external TTL or CMOS compatible clock (between 0 V and a level greater than 3 V) to the sync input through a 100-pF capacitor and a 1-k Ω resistor to ground at pin 5 as shown in [Figure 16](#).

When the SYNC function is used, current limit frequency foldback is not active. Therefore, the device may not be fully protected against extreme output short-circuit conditions (see [Additional Application Information](#)).

7.3.5 Feedback

This is the input to a two-stage, high-gain amplifier, which drives the PWM controller. It is necessary to connect pin 6 to the actual output of the power supply to set the dc output voltage. For the fixed output devices (3.3-V, 5-V, and 12-V outputs), a direct wire connection to the output is all that is required as internal gain setting resistors are provided inside the LM2677. For the adjustable output version, two external resistors are required to set the dc output voltage. For stable operation of the power supply, it is important to prevent coupling of any inductor flux to the feedback input.

7.3.6 ON/OFF

This input provides an electrical ON/OFF control of the power supply. Connecting this pin to ground or to any voltage less than 0.8 V completely turns OFF the regulator. The current drain from the input supply when OFF is only 50 μA . Pin 7 has an internal pullup current source of approximately 20 μA and a protection clamp Zener diode of 7 V to ground. When electrically driving the ON/OFF pin the high voltage level for the ON condition must not exceed the 6-V absolute maximum limit. When ON/OFF control is not required pin 7 must be left open circuited.

7.3.7 DAP (VSON Package)

The die attach pad (DAP) must be connected to PCB ground plane. For CAD and assembly guidelines, see application note, [AN-1187 Leadless Leadframe Package \(LLP\)](#).

7.4 Device Functional Modes

7.4.1 Shutdown Mode

The ON/OFF pin provides electrical ON and OFF control for the LM2677. When the voltage of this pin is lower than 1.4 V, the device is shutdown mode. The typical standby current in this mode is 20 μA .

7.4.2 Active Mode

When the voltage of the ON/OFF pin is higher than 1.4 V, the device starts switching, and the output voltage rises until it reaches a normal regulation voltage.

8 Application and Implementation

NOTE

Information in the following applications sections is not part of the TI component specification, and TI does not warrant its accuracy or completeness. TI's customers are responsible for determining suitability of components for their purposes. Customers should validate and test their design implementation to confirm system functionality.

8.1 Application Information

8.1.1 Inductor

The inductor is the key component in a switching regulator. For efficiency the inductor stores energy during the switch ON time and then transfers energy to the load while the switch is OFF.

Nomographs are used to select the inductance value required for a given set of operating conditions. The nomographs assume that the circuit is operating in continuous mode (the current flowing through the inductor never falls to zero). The magnitude of inductance is selected to maintain a maximum ripple current of 30% of the maximum load current. If the ripple current exceeds this 30% limit the next larger value is selected.

The inductors offered have been specifically manufactured to provide proper operation under all operating conditions of input and output voltage and load current. Several part types are offered for a given amount of inductance. Both surface mount and through-hole devices are available. The inductors from each of the three manufacturers have unique characteristics.

Renco: ferrite stick core inductors; benefits are typically lowest cost and can withstand ripple and transient peak currents above the rated value. These inductors have an external magnetic field, which may generate EMI.

Pulse Engineering: powdered iron toroid core inductors; these also can withstand higher than rated currents and, being toroid inductors, has low EMI.

Coilcraft: ferrite drum core inductors; these are the smallest physical-size inductors and are available only as surface mount components. These inductors also generate EMI but less than stick inductors.

8.1.2 Output Capacitor

The output capacitor acts to smooth the dc output voltage and also provides energy storage. Selection of an output capacitor, with an associated equivalent series resistance (ESR), impacts both the amount of output ripple voltage and stability of the control loop.

The output ripple voltage of the power supply is the product of the capacitor ESR and the inductor ripple current. The capacitor types recommended in the [Input and Output Capacitor Codes](#) were selected for having low ESR ratings.

In addition, both surface mount tantalum capacitors and through-hole aluminum electrolytic capacitors are offered as solutions.

Impacting frequency stability of the overall control loop, the output capacitance, in conjunction with the inductor, creates a double pole inside the feedback loop. In addition the capacitance and the ESR value create a zero. These frequency response effects together with the internal frequency compensation circuitry of the LM2677 modify the gain and phase shift of the closed loop system.

As a general rule for stable switching regulator circuits it is desired to have the unity gain bandwidth of the circuit to be limited to no more than one-sixth of the controller switching frequency. With the fixed 260-kHz switching frequency of the LM2677, the output capacitor is selected to provide a unity gain bandwidth of 40 kHz maximum. Each recommended capacitor value has been chosen to achieve this result.

In some cases multiple capacitors are required either to reduce the ESR of the output capacitor, to minimize output ripple (a ripple voltage of 1% of V_{out} or less is the assumed performance condition), or to increase the output capacitance to reduce the closed loop unity gain bandwidth (to less than 40 kHz). When parallel combinations of capacitors are required it has been assumed that each capacitor is the exact same part type.

Application Information (continued)

The RMS current and working voltage (WV) ratings of the output capacitor are also important considerations. In a typical step-down switching regulator, the inductor ripple current (set to be no more than 30% of the maximum load current by the inductor selection) is the current that flows through the output capacitor. The capacitor RMS current rating must be greater than this ripple current. The voltage rating of the output capacitor must be greater than 1.3 times the maximum output voltage of the power supply. If operation of the system at elevated temperatures is required, the capacitor voltage rating may be de-rated to less than the nominal room temperature rating. Careful inspection of the manufacturer's specification for de-rating of working voltage with temperature is important.

8.1.3 Input and Output Capacitor Codes

Table 1. Surface-Mount Capacitors⁽¹⁾

CAPACITOR REFERENCE CODE	AVX TPS SERIES			SPRAGUE 594D SERIES			KEMET T495 SERIES		
	C (μF)	WV (V)	IRMS (A)	C (μF)	WV (V)	IRMS (A)	C (μF)	WV (V)	IRMS (A)
C1	330	6.3	1.15	120	6.3	1.1	100	6.3	0.82
C2	100	10	1.1	220	6.3	1.4	220	6.3	1.1
C3	220	10	1.15	68	10	1.05	330	6.3	1.1
C4	47	16	0.89	150	10	1.35	100	10	1.1
C5	100	16	1.15	47	16	1	150	10	1.1
C6	33	20	0.77	100	16	1.3	220	10	1.1
C7	68	20	0.94	180	16	1.95	33	20	0.78
C8	22	25	0.77	47	20	1.15	47	20	0.94
C9	10	35	0.63	33	25	1.05	68	20	0.94
C10	22	35	0.66	68	25	1.6	10	35	0.63
C11	—	—	—	15	35	0.75	22	35	0.63
C12	—	—	—	33	35	1	4.7	50	0.66
C13	—	—	—	15	50	0.9	—	—	—

(1) Assumes worst case maximum input voltage and load current for a given inductance value

Table 2. Through-Hole Capacitors⁽¹⁾

CAPACITOR REFERENCE CODE	SANYO OS-CON SA SERIES			SANYO MV-GX SERIES			NICHICON PL SERIES			PANASONIC HFQ SERIES		
	C (μF)	WV (V)	IRMS (A)	C (μF)	WV (V)	IRMS (A)	C (μF)	WV (V)	IRMS (A)	C (μF)	WV (V)	IRMS (A)
C1	47	6.3	1	1000	6.3	0.8	680	10	0.8	82	35	0.4
C2	150	6.3	1.95	270	16	0.6	820	10	0.98	120	35	0.44
C3	330	6.3	2.45	470	16	0.75	1000	10	1.06	220	35	0.76
C4	100	10	1.87	560	16	0.95	1200	10	1.28	330	35	1.01
C5	220	10	2.36	820	16	1.25	2200	10	1.71	560	35	1.4
C6	33	16	0.96	1000	16	1.3	3300	10	2.18	820	35	1.62
C7	100	16	1.92	150	35	0.65	3900	10	2.36	1000	35	1.73
C8	150	16	2.28	470	35	1.3	6800	10	2.68	2200	35	2.8
C9	100	20	2.25	680	35	1.4	180	16	0.41	56	50	0.36
C10	47	25	2.09	1000	35	1.7	270	16	0.55	100	50	0.5
C11	—	—	—	220	63	0.76	470	16	0.77	220	50	0.92
C12	—	—	—	470	63	1.2	680	16	1.02	470	50	1.44
C13	—	—	—	680	63	1.5	820	16	1.22	560	50	1.68
C14	—	—	—	1000	63	1.75	1800	16	1.88	1200	50	2.22
C15	—	—	—	—	—	—	220	25	0.63	330	63	1.42

(1) Assumes worst case maximum input voltage and load current for a given inductance value

Table 2. Through-Hole Capacitors⁰ (continued)

CAPACITOR REFERENCE CODE	SANYO OS-CON SA SERIES			SANYO MV-GX SERIES			NICHICON PL SERIES			PANASONIC HFQ SERIES		
	C (μF)	WV (V)	IRMS (A)	C (μF)	WV (V)	IRMS (A)	C (μF)	WV (V)	IRMS (A)	C (μF)	WV (V)	IRMS (A)
C16	—	—	—	—	—	—	220	35	0.79	1500	63	2.51
C17	—	—	—	—	—	—	560	35	1.43	—	—	—
C18	—	—	—	—	—	—	2200	35	2.68	—	—	—
C19	—	—	—	—	—	—	150	50	0.82	—	—	—
C20	—	—	—	—	—	—	220	50	1.04	—	—	—
C21	—	—	—	—	—	—	330	50	1.3	—	—	—
C22	—	—	—	—	—	—	100	63	0.75	—	—	—
C23	—	—	—	—	—	—	390	63	1.62	—	—	—
C24	—	—	—	—	—	—	820	63	2.22	—	—	—
C25	—	—	—	—	—	—	1200	63	2.51	—	—	—

8.1.4 Input Capacitor

Fast changing currents in high-current switching regulators place a significant dynamic load on the unregulated power source. An input capacitor helps to provide additional current to the power supply as well as smooth out input voltage variations.

Like the output capacitor, the key specifications for the input capacitor are RMS current rating and working voltage. The RMS current flowing through the input capacitor is equal to one-half of the maximum dc load current so the capacitor must be rated to handle this. Paralleling multiple capacitors proportionally increases the current rating of the total capacitance. The voltage rating must also be selected to be 1.3 times the maximum input voltage. Depending on the unregulated input power source, under light load conditions the maximum input voltage could be significantly higher than normal operation and must be considered when selecting an input capacitor.

The input capacitor must be placed very close to the input pin of the LM2677. Due to relative high-current operation with fast transient changes, the series inductance of input connecting wires or PCB traces can create ringing signals at the input terminal which could possibly propagate to the output or other parts of the circuitry. It may be necessary in some designs to add a small valued (0.1 μF to 0.47 μF) ceramic type capacitor in parallel with the input capacitor to prevent or minimize any ringing.

8.1.5 Catch Diode

When the power switch in the LM2677 turns OFF, the current through the inductor continues to flow. The path for this current is through the diode connected between the switch output and ground. This forward biased diode clamps the switch output to a voltage less than ground. This negative voltage must be greater than -1 V, so TI recommends a low voltage drop (particularly at high current levels) Schottky diode. Total efficiency of the entire power supply is significantly impacted by the power lost in the output catch diode. The average current through the catch diode is dependent on the switch duty cycle (D) and is equal to the load current times (1-D). Use of a diode rated for much higher current than is required by the actual application helps to minimize the voltage drop and power loss in the diode.

During the switch ON-time the diode is reversed biased by the input voltage. The reverse voltage rating of the diode must be at least 1.3 times greater than the maximum input voltage.

8.1.6 Boost Capacitor

The boost capacitor creates a voltage used to overdrive the gate of the internal power MOSFET. This improves efficiency by minimizing the on-resistance of the switch and associated power loss. For all applications, TI recommends using a 0.01-μF, 50-V ceramic capacitor.

8.1.7 SYNC Components

When synchronizing the LM2677 with an external clock TI recommends connecting the clock to pin 5 through a series 100-pF capacitor, and connecting a 1-k Ω resistor to ground from pin 5. This RC network creates a short 100-nS pulse on each positive edge of the clock to reset the internal ramp oscillator. The reset time of the oscillator is approximately 300 nS.

8.1.8 Additional Application Information

When the output voltage is greater than approximately 6 V, and the duty cycle at minimum input voltage is greater than approximately 50%, the designer must exercise caution in selection of the output filter components. When an application designed to these specific operating conditions is subjected to a current limit fault condition, it may be possible to observe a large hysteresis in the current limit. This can affect the output voltage of the device until the load current is reduced sufficiently to allow the current limit protection circuit to reset itself.

Under current limiting conditions, the LM267x is designed to respond in the following manner:

1. At the moment when the inductor current reaches the current limit threshold, the ON-pulse is immediately terminated. This happens for any application condition.
2. However, the current limit block is also designed to momentarily reduce the duty cycle to below 50% to avoid subharmonic oscillations, which could cause the inductor to saturate.
3. Thereafter, once the inductor current falls below the current limit threshold, there is a small relaxation time during which the duty cycle progressively rises back above 50% to the value required to achieve regulation.

If the output capacitance is sufficiently *large*, it may be possible that as the output tries to recover, the output capacitor charging current is large enough to repeatedly re-trigger the current limit circuit before the output has fully settled. This condition is exacerbated with higher output voltage settings because the energy requirement of the output capacitor varies as the square of the output voltage ($\frac{1}{2} CV^2$), thus requiring an increased charging current.

A simple test to determine if this condition might exist for a suspect application is to apply a short circuit across the output of the converter, and then remove the shorted output condition. In an application with properly selected external components, the output recovers smoothly.

Practical values of external components that have been experimentally found to work well under these specific operating conditions are $C_{OUT} = 47 \mu\text{F}$, $L = 22 \mu\text{H}$. It must be noted that even with these components, for a device's current limit of I_{CLIM} , the maximum load current under which the possibility of the large current limit hysteresis can be minimized is $I_{CLIM}/2$. For example, if the input is 24 V and the set output voltage is 18 V, then for a desired maximum current of 1.5 A, the current limit of the chosen switcher must be confirmed to be at least 3 A.

Under extreme over-current or short circuit conditions, the LM267X employs frequency foldback in addition to the current limit. If the cycle-by-cycle inductor current increases above the current limit threshold (due to short circuit or inductor saturation for example) the switching frequency is automatically reduced to protect the IC. Frequency below 100 kHz is typical for an extreme short circuit condition.

8.2 Typical Application

8.2.1 Fixed Output Voltage Applications

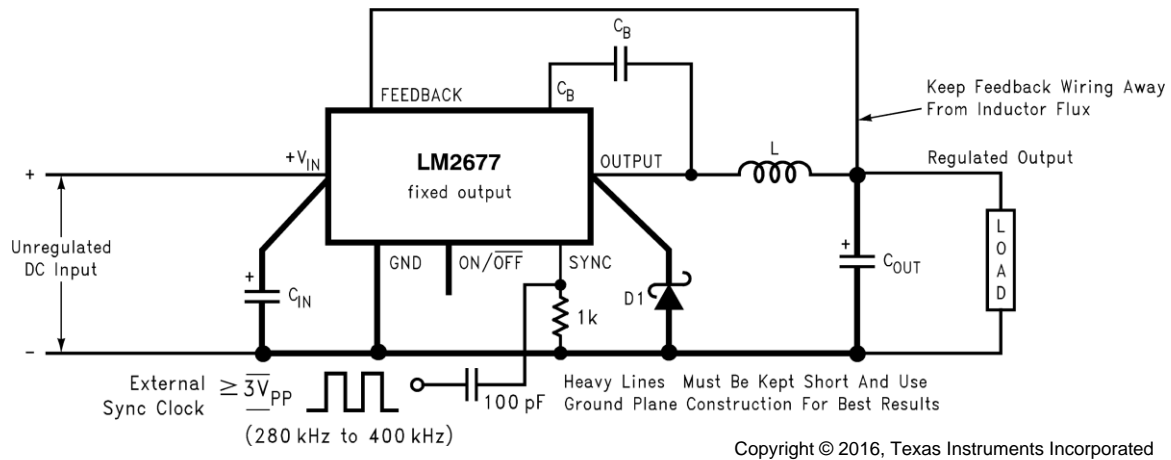

Figure 16. Basic Circuit For Fixed Output Voltage Applications

8.2.1.1 Design Requirements

Table 3 lists the design requirements for the adjustable output voltage application.

Table 3. Design Parameters

PARAMETER	VALUE
Required output voltage, V_{OUT}	3.3 V
Maximum DC input voltage, V_{IN_MAX}	16 V
Maximum output load current, I_{LOAD_MAX}	2.5 A

8.2.1.2 Detailed Design Procedure

A system logic power supply bus of 3.3 V is to be generated from a wall adapter which provides an unregulated DC voltage of 13 V to 16 V. The maximum load current is 2.5 A. Through-hole components are preferred.

Step 1: Select an LM2677T, 3.3 V. The output voltage has a tolerance of $\pm 2\%$ at room temperature and $\pm 3\%$ over the full operating temperature range.

Step 2: Use the nomograph for the 3.3 V device, Figure 17. The intersection of the 16-V horizontal line ($V_{in\ max}$) and the 2.5-A vertical line ($I_{load\ max}$) indicates that L33, a 22- μ H inductor, is required. From Table 4, L33 in a through-hole component is available from Renco with part number RL-1283-22-43 or part number PE-53933 from Pulse Engineering.

Table 4. Inductor Manufacturer Part Numbers⁽¹⁾

INDUCTOR REF. #	INDUCTANCE (μ H)	CURRENT (A)	RENCO		PULSE ENGINEERING		COILCRAFT
			THROUGH HOLE	SURFACE MOUNT	THROUGH HOLE	SURFACE MOUNT	SURFACE MOUNT
L23	33	1.35	RL-5471-7	RL1500-33	PE-53823	PE-53823S	DO3316-333
L24	22	1.65	RL-1283-22-43	RL1500-22	PE-53824	PE-53824S	DO3316-223
L25	15	2.00	RL-1283-15-43	RL1500-15	PE-53825	PE-53825S	DO3316-153
L29	100	1.41	RL-5471-4	RL-6050-100	PE-53829	PE-53829S	DO5022P-104
L30	68	1.71	RL-5471-5	RL6050-68	PE-53830	PE-53830S	DO5022P-683
L31	47	2.06	RL-5471-6	RL6050-47	PE-53831	PE-53831S	DO5022P-473
L32	33	2.46	RL-5471-7	RL6050-33	PE-53932	PE-53932S	DO5022P-333
L33	22	3.02	RL-1283-22-43	RL6050-22	PE-53933	PE-53933S	DO5022P-223

(1) Assumes worst case maximum input voltage and load current for a given inductance value

Table 4. Inductor Manufacturer Part Numbers⁽¹⁾ (continued)

INDUCTOR REF. #	INDUCTANCE (μH)	CURRENT (A)	RENCO		PULSE ENGINEERING		COILCRAFT
			THROUGH HOLE	SURFACE MOUNT	THROUGH HOLE	SURFACE MOUNT	SURFACE MOUNT
L34	15	3.65	RL-1283-15-43	—	PE-53934	PE-53934S	DO5022P-153
L38	68	2.97	RL-5472-2	—	PE-54038	PE-54038S	—
L39	47	3.57	RL-5472-3	—	PE-54039	PE-54039S	—
L40	33	4.26	RL-1283-33-43	—	PE-54040	PE-54040S	—
L41	22	5.22	RL-1283-22-43	—	PE-54041	P0841	—
L44	68	3.45	RL-5473-3	—	PE-54044	—	—
L45	10	4.47	RL-1283-10-43	—	—	P0845	DO5022P-103HC
L46	15	5.60	RL-1283-15-43	—	—	P0846	DO5022P-153HC
L47	10	5.66	RL-1283-10-43	—	—	P0847	DO5022P-103HC
L48	47	5.61	RL-1282-47-43	—	—	P0848	—
L49	33	5.61	RL-1282-33-43	—	—	P0849	—

Step 3: Use [Table 5](#) to determine an output capacitor. With a 3.3-V output and a 22-μH inductor there are four through-hole output capacitor solutions with the number of same type capacitors to be paralleled and an identifying capacitor code given. [Table 1](#) provides the actual capacitor characteristics. Any of the following choices works in the circuit:

- 1 × 220-μF, 10-V Sanyo OS-CON (code C5)
- 1 × 1000-μF, 35-V Sanyo MV-GX (code C10)
- 1 × 2200-μF, 10-V Nichicon PL (code C5)
- 1 × 1000-μF, 35-V Panasonic HFQ (code C7)

Table 5. Output Capacitors for Fixed Output Voltage Application⁽¹⁾

OUTPUT VOLTAGE (V)	INDUCTANCE (μH)	SURFACE MOUNT					
		AVX TPS SERIES		SPRAGUE 594D SERIES		KEMET T495 SERIES	
		NO. ⁽²⁾	C CODE ⁽³⁾	NO. ⁽²⁾	C CODE ⁽³⁾	NO. ⁽²⁾	C CODE ⁽³⁾
3.3	10	5	C1	5	C1	5	C2
	15	4	C1	4	C1	4	C3
	22	3	C2	2	C7	3	C4
	33	1	C1	2	C7	3	C4
5	10	4	C2	4	C6	4	C4
	15	3	C3	2	C7	3	C5
	22	3	C2	2	C7	3	C4
	33	2	C2	2	C3	2	C4
	47	2	C2	1	C7	2	C4
12	10	4	C5	3	C6	5	C9
	15	3	C5	2	C7	4	C9
	22	2	C5	2	C6	3	C8
	33	2	C5	1	C7	3	C8
	47	2	C4	1	C6	2	C8
	68	1	C5	1	C5	2	C7
	100	1	C4	1	C5	1	C8

(1) Assumes worst case maximum input voltage and load current for a given inductance value

(2) No. represents the number of identical capacitor types to be connected in parallel

(3) C Code indicates the Capacitor Reference number in [Table 1](#) for identifying the specific component from the manufacturer.

Step 4: Use [Table 6](#) to select an input capacitor. With 3.3-V output and 22- μ H there are three through-hole solutions. These capacitors provide a sufficient voltage rating and an rms current rating greater than 1.25 A (1/2 $I_{load\ max}$). Again using [Table 1](#) for specific component characteristics the following choices are suitable:

- 1 \times 1000- μ F, 63-V Sanyo MV-GX (code C14)
- 1 \times 820- μ F, 63-V Nichicon PL (code C24)
- 1 \times 560- μ F, 50-V Panasonic HFQ (code C13)

Table 6. Input Capacitors for Fixed Output Voltage Application⁽¹⁾

OUTPUT VOLTAGE (V)	INDUCTANCE (μ H)	SURFACE MOUNT					
		AVX TPS SERIES ⁽²⁾		SPRAGUE 594D SERIES		KEMET T495 SERIES	
		NO. ⁽³⁾	C CODE ⁽⁴⁾	NO. ⁽³⁾	C CODE ⁽⁴⁾	NO. ⁽³⁾	C CODE ⁽⁴⁾
3.3	10	3	C7	2	C10	3	C9
	15	*	*	3	C13	4	C12
	22	*	*	2	C13	3	C12
	33	*	*	2	C13	3	C12
5	10	3	C4	2	C6	3	C9
	15	4	C9	3	C12	4	C10
	22	*	*	3	C13	4	C12
	33	*	*	2	C13	3	C12
	47	*	*	1	C13	2	C12
12	10	4	C9	2	C10	4	C10
	15	4	C8	2	C10	4	C10
	22	4	C9	3	C12	4	C10
	33	*	*	3	C13	4	C12
	47	*	*	2	C13	3	C12
	68	*	*	2	C13	2	C12
	100	*	*	1	C13	2	C12

(1) Assumes worst case maximum input voltage and load current for a given inductance value

(2) * Check voltage rating of capacitors to be greater than application input voltage.

(3) No. represents the number of identical capacitor types to be connected in parallel

(4) C Code indicates the Capacitor Reference number in [Table 1](#) for identifying the specific component from the manufacturer.

Step 5: From [Table 7](#) a 3-A Schottky diode must be selected. For through-hole components, 20-V rated diodes are sufficient and 2 part types are suitable, 1N5820 and SR302.

Table 7. Schottky Diode Selection Table

REVERSE VOLTAGE (V)	SURFACE MOUNT		THROUGH HOLE	
	3 A	5 A OR MORE	3 A	5 A OR MORE
20	SK32	—	1N5820	—
		—	SR302	—
30	SK33	MBRD835L	1N5821	—
	30WQ03F		31DQ03	—
40	SK34	MBRB1545CT	1N5822	—
	30BQ040	6TQ045S	MBR340	MBR745
	30WQ04F	—	31DQ04	80SQ045
	MBRS340	—	SR403	6TQ045
	MBRD340	—	—	—
50 or more	SK35	—	MBR350	—
	30WQ05F	—	31DQ05	—
	—	—	SR305	—

Step 6: A 0.01- μF capacitor is used for CBoost.

8.2.1.3 Application Curves

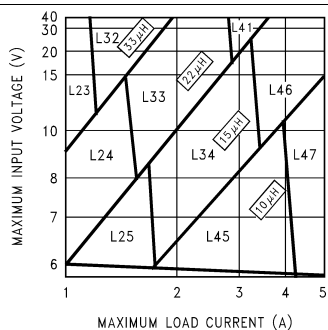

Figure 17. LM2677, 3.3 V

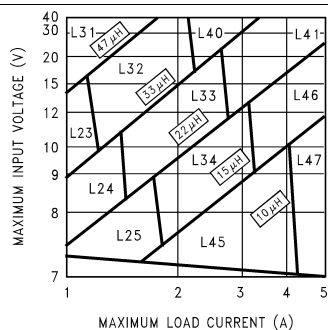

Figure 18. LM2677, 5 V

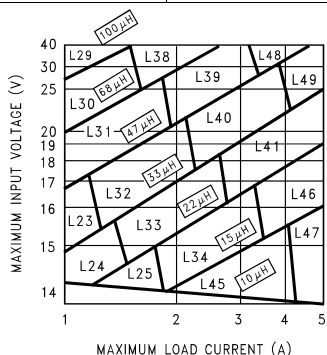
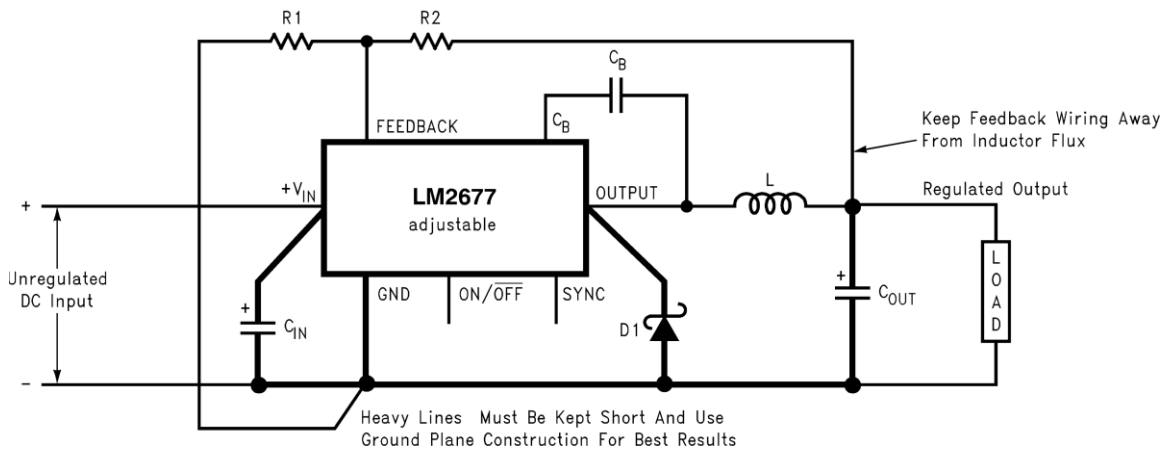

Figure 19. LM2677, 12 V

8.2.2 Adjustable Output Voltage Applications

Locate the Programming Resistors near the Feedback Pin Using Short Leads



Copyright © 2016, Texas Instruments Incorporated

Figure 20. Basic Circuit For Adjustable Output Voltage Applications

8.2.2.1 Design Requirements

Table 8 lists the design requirements for the adjustable output voltage application.

Table 8. Design Parameters

PARAMETER	VALUE
Required output voltage, V_{OUT}	14.8 V
Maximum DC input voltage, V_{IN_MAX}	28 V
Maximum output load current, I_{LOAD_MAX}	2 A

8.2.2.2 Detailed Design Procedure

In this example it is desired to convert the voltage from a two-battery automotive power supply (voltage range of 20 V to 28 V, typical in large truck applications) to the 14.8 VDC alternator supply typically used to power electronic equipment from single battery 12-V vehicle systems. The load current required is 2 A maximum. It is also desired to implement the power supply with all surface mount components.

Step 1: Select an LM2677S-ADJ to set the output voltage to 14.9 V that chooses between two required resistors (R1 and R2 in Figure 20). For the adjustable device, the output voltage is set by Equation 1.

$$V_{OUT} = V_{FB} \left(1 + \frac{R_2}{R_1} \right)$$

where

- V_{FB} is the feedback voltage of typically 1.21 V (1)

A recommended value to use for R1 is 1K. In this example then R2 is determined with Equation 2.

$$R_2 = R_1 \left(\frac{V_{OUT}}{V_{FB}} - 1 \right) = 1 \text{ k}\Omega \left(\frac{12.8 \text{ V}}{1.21 \text{ V}} - 1 \right) \quad (2)$$

R2 = 11.2 kΩ

The closest standard 1% tolerance value to use is 11.3 kΩ. This sets the nominal output voltage to 14.88 V which is within 0.5% of the target value.

Step 2: To use the nomograph for the adjustable device, Figure 21, requires a calculation of the inductor Volt•microsecond constant ($E \times T$ expressed in $V \times \mu\text{s}$) from Equation 3.

$$E \times T = \left(V_{IN(MAX)} - V_{OUT} - V_{SAT} \right) \times \frac{V_{OUT} + V_D}{V_{IN(MAX)} - V_{SAT} + V_D} \times \frac{1000}{260} (V \times \mu\text{s})$$

where

- V_{SAT} is the voltage drop across the internal power switch which is $R_{ds(ON)}$ times I_{load} (3)

In this example, this would be typically $0.15 \Omega \times 2 \text{ A}$ or 0.3 V and V_D is the voltage drop across the forward biased Schottky diode, typically 0.5 V. The switching frequency of 260 kHz is the nominal value to use to estimate the ON-time of the switch during which energy is stored in the inductor. For this example $E \times T$ is found with Equation 4 and Equation 5.

$$E \times T = (28 - 14.8 - 0.3) \times \frac{14.8 + 0.5}{28 - 0.3 + 0.5} \times \frac{1000}{260} (V \times \mu\text{s}) \quad (4)$$

$$E \times T = (12.9 \text{ V}) \times \frac{15.3}{28.2} \times 3.85 (V \times \mu\text{s}) = 26.9 (V \times \mu\text{s}) \quad (5)$$

Using Figure 21, the intersection of 27 $V \times \mu\text{s}$ horizontally and the 2-A vertical line ($I_{load \text{ max}}$) indicates that L38, a 68-μH inductor, must be used. L38 in a surface mount component is available from Pulse Engineering with part number PE-54038S.

Step 3: Use [Table 9](#) and [Table 10](#) to determine an output capacitor. With a 14.8-V output the 12.5-V to 15-V row is used and with a 68- μ H inductor there are three surface mount output capacitor solutions. [Table 1](#) provides the actual capacitor characteristics based on the C Code number. Any of the following choices can be used:

- 1 \times 33- μ F, 20-V AVX TPS (code C6)
- 1 \times 47- μ F, 20-V Sprague 594 (code C8)
- 1 \times 47- μ F, 20-V Kemet T495 (code C8)

Table 9. Surface-Mount Output Capacitors

OUTPUT VOLTAGE (V)	INDUCTANCE (μH)	AVX TPS SERIES		SPRAGUE 594D SERIES		KEMET T495 SERIES	
		NO. (1)	C CODE (2)	NO. (1)	C CODE (2)	NO. (1)	C CODE (2)
1.21 to 2.50	33 ⁽³⁾	7	C1	6	C2	7	C3
	47 ⁽³⁾	5	C1	4	C2	5	C3
2.5 to 3.75	33 ⁽³⁾	4	C1	3	C2	4	C3
	47 ⁽³⁾	3	C1	2	C2	3	C3
3.75 to 5	22	4	C1	3	C2	4	C3
	33	3	C1	2	C2	3	C3
	47	2	C1	2	C2	2	C3
5 to 6.25	22	3	C2	1	C3	3	C4
	33	2	C2	2	C3	2	C4
	47	2	C2	2	C3	2	C4
	68	1	C2	1	C3	1	C4
6.25 to 7.5	22	3	C2	1	C4	3	C4
	33	2	C2	1	C3	2	C4
	47	1	C3	1	C4	1	C6
	68	1	C2	1	C3	1	C4
7.5 to 10	33	2	C5	1	C6	2	C8
	47	1	C5	1	C6	2	C8
	68	1	C5	1	C6	1	C8
	100	1	C4	1	C5	1	C8
10 to 12.5	33	1	C5	1	C6	2	C8
	47	1	C5	1	C6	2	C8
	68	1	C5	1	C6	1	C8
	100	1	C5	1	C6	1	C8
12.5 to 15	33	1	C6	1	C8	1	C8
	47	1	C6	1	C8	1	C8
	68	1	C6	1	C8	1	C8
	100	1	C6	1	C8	1	C8
15 to 20	33	1	C8	1	C10	2	C10
	47	1	C8	1	C9	2	C10
	68	1	C8	1	C9	2	C10
	100	1	C8	1	C9	1	C10
20 to 30	33	2	C9	2	C11	2	C11
	47	1	C10	1	C12	1	C11
	68	1	C9	1	C12	1	C11
	100	1	C9	1	C12	1	C11
30 to 37	10	—	—	4	C13	8	C12
	15	—	—	3	C13	5	C12
	22	No values available		2	C13	4	C12
	33	No values available		1	C13	3	C12
	47	—	—	1	C13	2	C12
	68	—	—	1	C13	2	C12

- (1) No. represents the number of identical capacitor types to be connected in parallel
 (2) C Code indicates the Capacitor Reference number in [Table 1](#) for identifying the specific component from the manufacturer.
 (3) Set to a higher value for a practical design solution.

Table 10. Through-Hole Output Capacitors

OUTPUT VOLTAGE (V)	INDUCTANCE (μH)	SANYO OS-CON SA SERIES		SANYO MV-GX SERIES		NICHICON PL SERIES		PANASONIC HFQ SERIES	
		NO. (1)	C CODE (2)	NO. (1)	C CODE (2)	NO. (1)	C CODE (2)	NO. (1)	C CODE (2)
1.21 to 2.50	33 ⁽³⁾	2	C3	5	C1	5	C3	3	C
	47 ⁽³⁾	2	C2	4	C1	3	C3	2	C5
2.5 to 3.75	33 ⁽³⁾	1	C3	3	C1	3	C1	2	C5
	47 ⁽³⁾	1	C2	2	C1	2	C3	1	C5
3.75 to 5	22	1	C3	3	C1	3	C1	2	C5
	33	1	C2	2	C1	2	C1	1	C5
	47	1	C2	2	C1	1	C3	1	C5
5 to 6.25	22	1	C5	2	C6	2	C3	2	C5
	33	1	C4	1	C6	2	C1	1	C5
	47	1	C4	1	C6	1	C3	1	C5
	68	1	C4	1	C6	1	C1	1	C5
6.25 to 7.5	22	1	C5	1	C6	2	C1	1	C5
	33	1	C4	1	C6	1	C3	1	C5
	47	1	C4	1	C6	1	C1	1	C5
	68	1	C4	1	C2	1	C1	1	C5
7.5 to 10	33	1	C7	1	C6	1	C14	1	C5
	47	1	C7	1	C6	1	C14	1	C5
	68	1	C7	1	C2	1	C14	1	C2
	100	1	C7	1	C2	1	C14	1	C2
10 to 12.5	33	1	C7	1	C6	1	C14	1	C5
	47	1	C7	1	C2	1	C14	1	C5
	68	1	C7	1	C2	1	C9	1	C2
	100	1	C7	1	C2	1	C9	1	C2
12.5 to 15	33	1	C9	1	C10	1	C15	1	C2
	47	1	C9	1	C10	1	C15	1	C2
	68	1	C9	1	C10	1	C15	1	C2
	100	1	C9	1	C10	1	C15	1	C2
15 to 20	33	1	C10	1	C7	1	C15	1	C2
	47	1	C10	1	C7	1	C15	1	C2
	68	1	C10	1	C7	1	C15	1	C2
	100	1	C10	1	C7	1	C15	1	C2
20 to 30	33	—	—	1	C7	1	C16	1	C2
	47	No values available		1	C7	1	C16	1	C2
	68	No values available		1	C7	1	C16	1	C2
	100	—	—	1	C7	1	C16	1	C2
30 to 37	10	—	—	1	C12	1	C20	1	C10
	15	—	—	1	C11	1	C20	1	C11
	22	No values available		1	C11	1	C20	1	C10
	33	No values available		1	C11	1	C20	1	C10
	47	—	—	1	C11	1	C20	1	C10
	68	—	—	1	C11	1	C20	1	C10

(1) No. represents the number of identical capacitor types to be connected in parallel

(2) C Code indicates the Capacitor Reference number in [Table 1](#) for identifying the specific component from the manufacturer.

(3) Set to a higher value for a practical design solution.

NOTE

When using the adjustable device in low voltage applications (less than 3-V output), if the nomograph, [Figure 21](#), selects an inductance of 22 μH or less, [Table 9](#) does not provide an output capacitor solution. With these conditions the number of output capacitors required for stable operation becomes impractical. TI recommends using either a 33- μH or 47- μH inductor and the output capacitors from [Table 9](#).

Step 4: An input capacitor for this example requires at least a 35-V WV rating with an rms current rating of 1 A (1/2 Iout max). From [Table 1](#) it can be seen that C12, a 33- μF , 35-V capacitor from Sprague, has the required voltage/current rating of the surface mount components.

Step 5: From [Table 7](#) a 3-A Schottky diode must be selected. For surface mount diodes with a margin of safety on the voltage rating one of five diodes can be used:

- SK34
- 30BQ040
- 30WQ04F
- MBRS340
- MBRD340

Step 6: A 0.01- μF capacitor is used for Cboost.

8.2.2.3 Application Curve

Figure 21. LM2677, Adjustable

9 Power Supply Recommendations

Power supply design using the LM2677 is greatly simplified by using recommended external components. A wide range of inductors, capacitors, and Schottky diodes from several manufacturers have been evaluated for use in designs that cover the full range of capabilities (input voltage, output voltage, and load current) of the LM2677. A simple design procedure using nomographs and component tables provided in this data sheet leads to a working design with very little effort.

The individual components from the various manufacturers called out for use are still just a small sample of the vast array of components available in the industry. While these components are recommended, they are not exclusively the only components for use in a design. After a close comparison of component specifications, equivalent devices from other manufacturers could be substituted for use in an application.

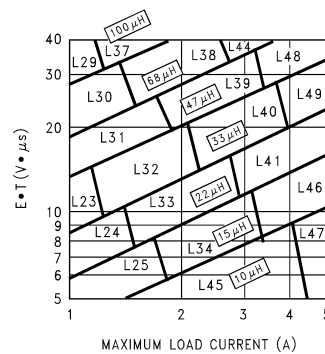
The input voltage for the power supply is connected to pin 2. In addition to providing energy to the load the input voltage also provides bias for the internal circuitry of the LM2677. For ensured performance the input voltage must be in the range of 8 V to 40 V. For best performance of the power supply the input pin must always be bypassed with an input capacitor placed close to pin 2.

10 Layout

10.1 Layout Guidelines

Layout is very important in switching regulator designs. Rapidly switching currents associated with wiring inductance can generate voltage transients which can cause problems. For minimal inductance and ground loops, the wires indicated by heavy lines (in [Figure 16](#) and [Figure 20](#)) must be wide printed circuit traces and must be kept as short as possible. For best results, external components must be placed as close to the switcher IC as possible using ground plane construction or single-point grounding. If open-core inductors are used, take special care as to the location and positioning of this type of inductor. Allowing the inductor flux to intersect sensitive feedback, IC ground path, and C wiring can cause problems.

When using the adjustable version, take special care as to the location of the feedback resistors and the associated wiring. Physically place both resistors near the IC, and route the wiring away from the inductor, especially an open-core type of inductor.

10.1.1 VSON Package Devices

The LM2677 is offered in the 14-pin VSON surface mount package to allow for a significantly decreased footprint with equivalent power dissipation compared to the TO-220 or TO-263. For details on mounting and soldering specifications, see application note, [AN-1187 Leadless Leadframe Package \(LLP\)](#).

10.2 Layout Example

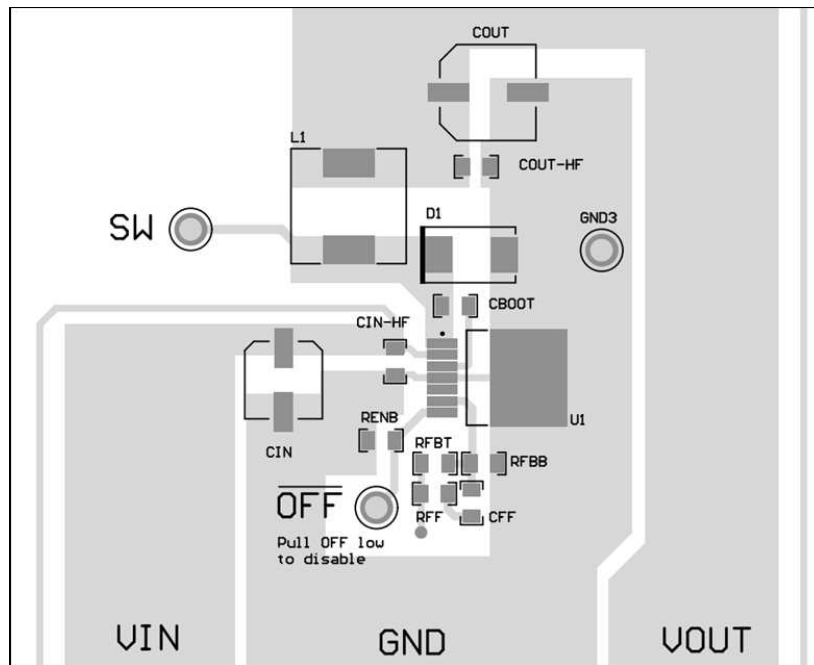

Figure 22. LM2677 Sample Layout

11 Device and Documentation Support

11.1 Documentation Support

11.1.1 Related Documentation

For related documentation see the following:

[AN-1187 Leadless Leadframe Package \(LLP\) \(SNOA401\)](#)

11.2 Receiving Notification of Documentation Updates

To receive notification of documentation updates, navigate to the device product folder on ti.com. In the upper right corner, click on *Alert me* to register and receive a weekly digest of any product information that has changed. For change details, review the revision history included in any revised document.

11.3 Community Resources

The following links connect to TI community resources. Linked contents are provided "AS IS" by the respective contributors. They do not constitute TI specifications and do not necessarily reflect TI's views; see TI's [Terms of Use](#).

TI E2E™ Online Community *TI's Engineer-to-Engineer (E2E) Community*. Created to foster collaboration among engineers. At e2e.ti.com, you can ask questions, share knowledge, explore ideas and help solve problems with fellow engineers.

Design Support *TI's Design Support* Quickly find helpful E2E forums along with design support tools and contact information for technical support.

11.4 Trademarks

E2E is a trademark of Texas Instruments.

SIMPLE SWITCHER is a registered trademark of Texas Instruments.

All other trademarks are the property of their respective owners.

11.5 Electrostatic Discharge Caution



These devices have limited built-in ESD protection. The leads should be shorted together or the device placed in conductive foam during storage or handling to prevent electrostatic damage to the MOS gates.

11.6 Glossary

[SLYZ022](#) — *TI Glossary*.

This glossary lists and explains terms, acronyms, and definitions.

12 Mechanical, Packaging, and Orderable Information

The following pages include mechanical, packaging, and orderable information. This information is the most current data available for the designated devices. This data is subject to change without notice and revision of this document. For browser-based versions of this data sheet, refer to the left-hand navigation.

NHM0014A

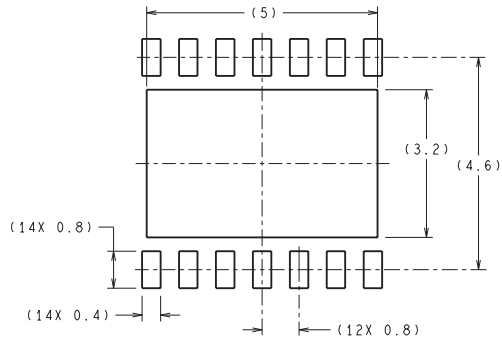

DIMENSIONS ARE IN MILLIMETERS
DIMENSIONS IN () FOR REFERENCE ONLY

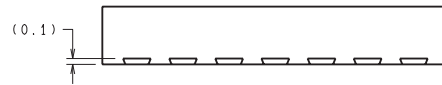

RECOMMENDED LAND PATTERN

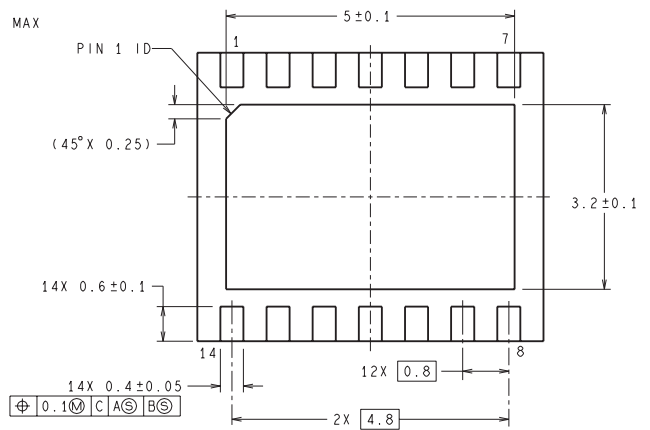
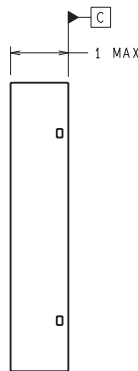
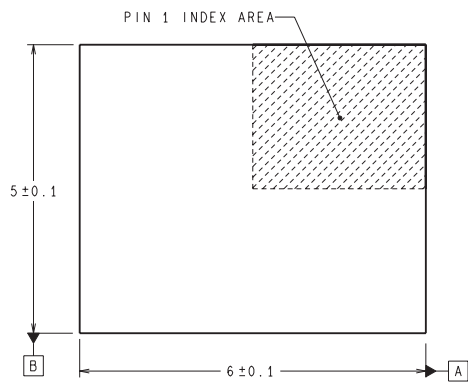

SRC14A (Rev A)

NDZ0007B

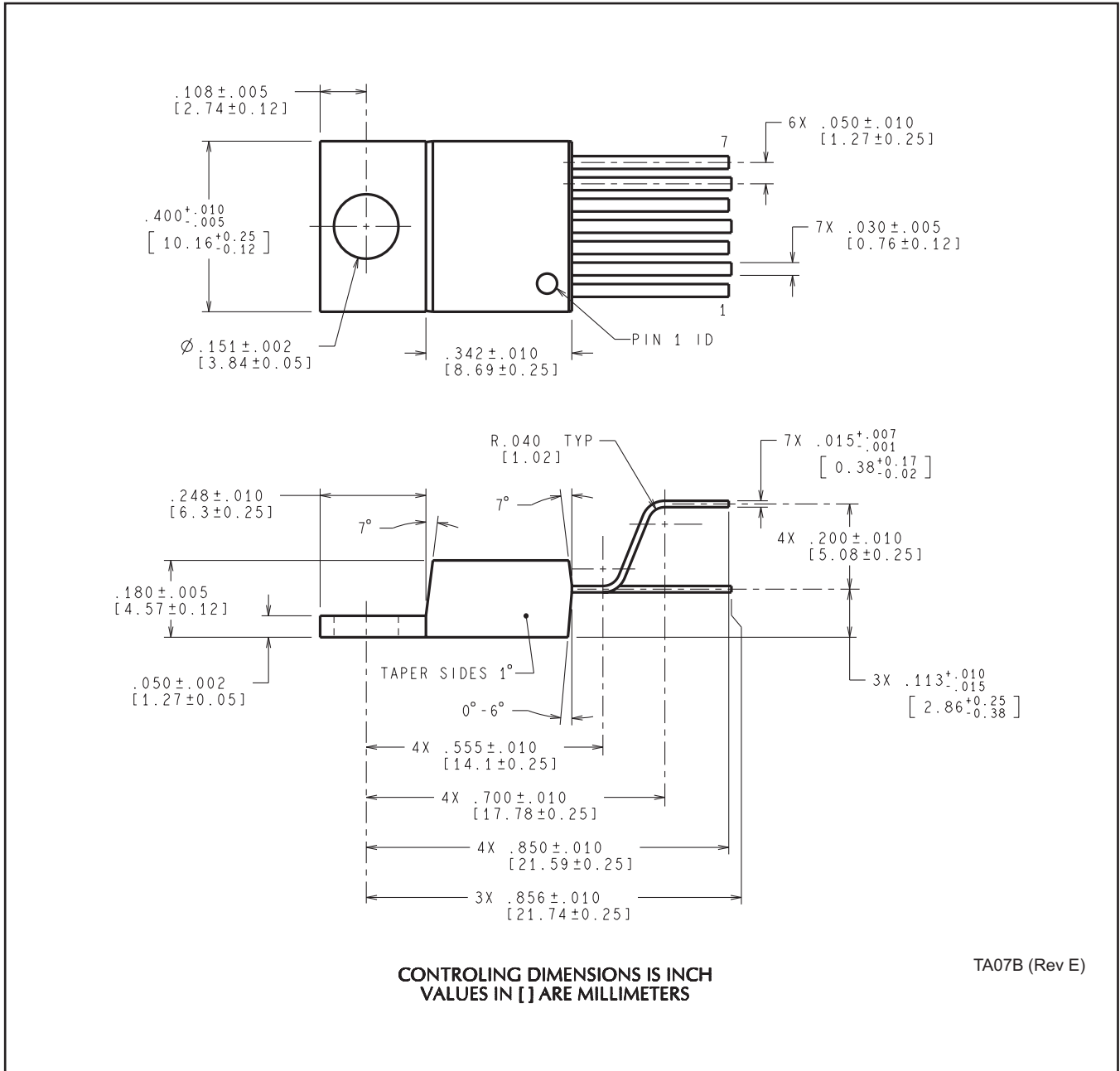

KTW (R-PSFM-G7)

PLASTIC FLANGE-MOUNT

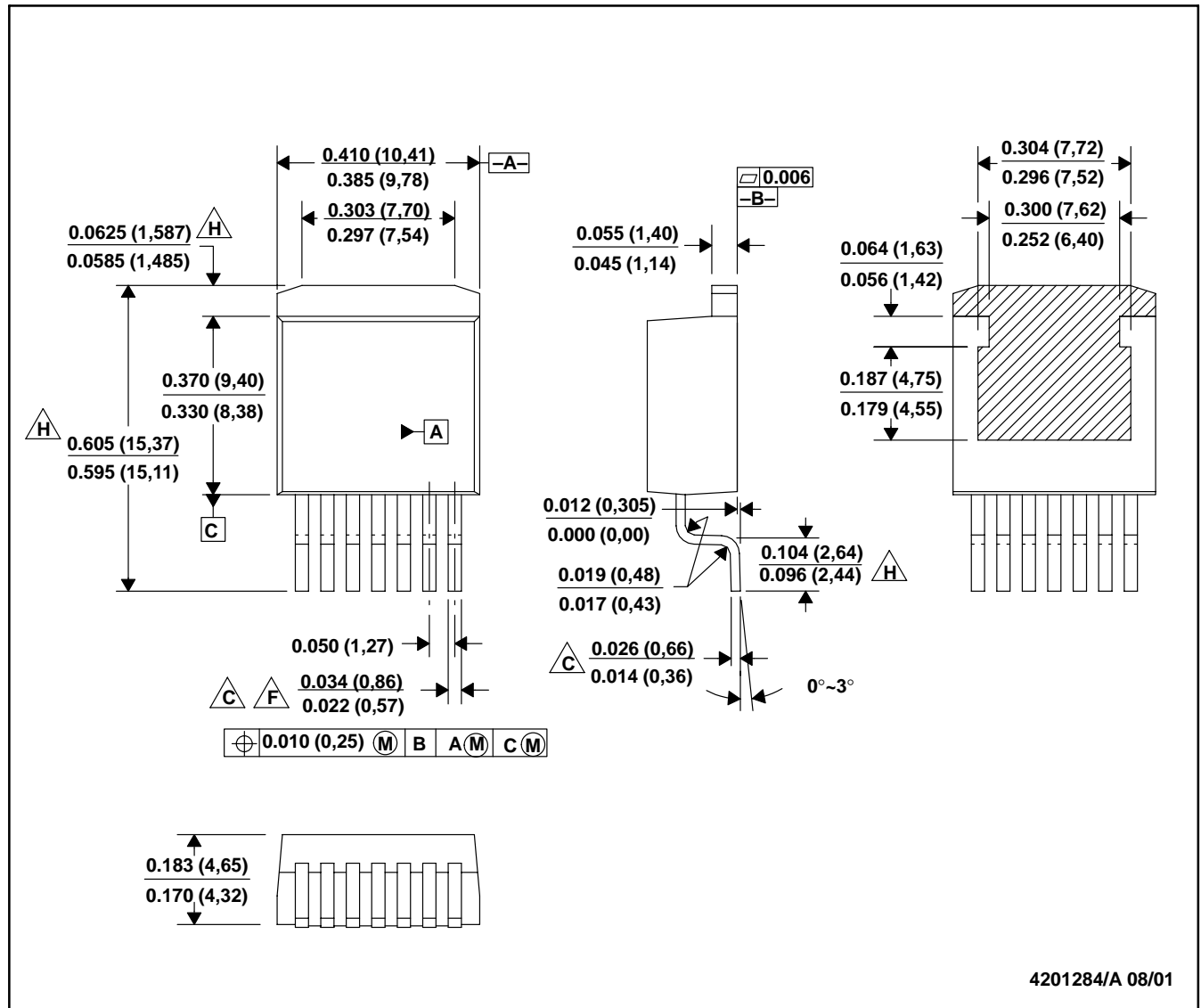

4201284/A 08/01

- NOTES:
- All linear dimensions are in inches (millimeters).
 - This drawing is subject to change without notice.
 - $\triangle C$: Lead width and height dimensions apply to the plated lead.
 - Leads are not allowed above the Datum B.
 - Stand-off height is measured from lead tip with reference to Datum B.
 - $\triangle F$: Lead width dimension does not include dambar protrusion. Allowable dambar protrusion shall not cause the lead width to exceed the maximum dimension by more than 0.003".
 - Cross-hatch indicates exposed metal surface.
 - $\triangle H$: Falls within JEDEC MO-169 with the exception of the dimensions indicated.

IMPORTANT NOTICE AND DISCLAIMER

TI PROVIDES TECHNICAL AND RELIABILITY DATA (INCLUDING DATA SHEETS), DESIGN RESOURCES (INCLUDING REFERENCE DESIGNS), APPLICATION OR OTHER DESIGN ADVICE, WEB TOOLS, SAFETY INFORMATION, AND OTHER RESOURCES "AS IS" AND WITH ALL FAULTS, AND DISCLAIMS ALL WARRANTIES, EXPRESS AND IMPLIED, INCLUDING WITHOUT LIMITATION ANY IMPLIED WARRANTIES OF MERCHANTABILITY, FITNESS FOR A PARTICULAR PURPOSE OR NON-INFRINGEMENT OF THIRD PARTY INTELLECTUAL PROPERTY RIGHTS.

These resources are intended for skilled developers designing with TI products. You are solely responsible for (1) selecting the appropriate TI products for your application, (2) designing, validating and testing your application, and (3) ensuring your application meets applicable standards, and any other safety, security, regulatory or other requirements.

These resources are subject to change without notice. TI grants you permission to use these resources only for development of an application that uses the TI products described in the resource. Other reproduction and display of these resources is prohibited. No license is granted to any other TI intellectual property right or to any third party intellectual property right. TI disclaims responsibility for, and you will fully indemnify TI and its representatives against, any claims, damages, costs, losses, and liabilities arising out of your use of these resources.

TI's products are provided subject to [TI's Terms of Sale](#) or other applicable terms available either on [ti.com](https://www.ti.com) or provided in conjunction with such TI products. TI's provision of these resources does not expand or otherwise alter TI's applicable warranties or warranty disclaimers for TI products.

TI objects to and rejects any additional or different terms you may have proposed.

Mailing Address: Texas Instruments, Post Office Box 655303, Dallas, Texas 75265
Copyright © 2023, Texas Instruments Incorporated