

Oct.1.2020 Copyright 2020 HIROSE ELECTRIC CO., LTD. All Rights Reserved.
In case of consideration for using Automotive equipment / device which demand high reliability, kindly contact our sales window correspondents.

COUNT	DESCRIPTION OF REVISIONS	BY	CHKD	DATE	COUNT	DESCRIPTION OF REVISIONS	BY	CHKD	DATE
△				..	△				..
△				..	△				..
△				..	△				..

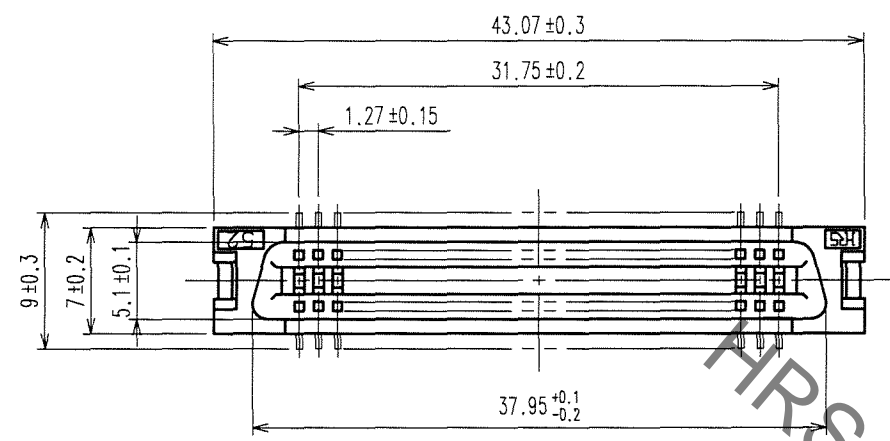

RECOMMENDED LAND PATTERN DIMENSION OF PCB (MOUNTING SIDE)

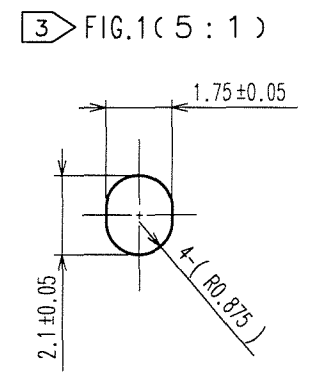
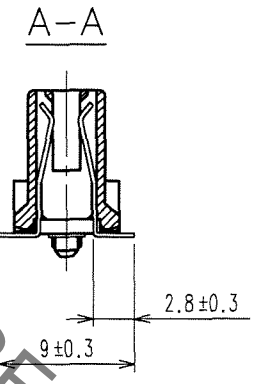
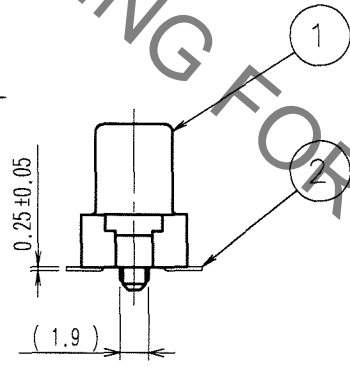
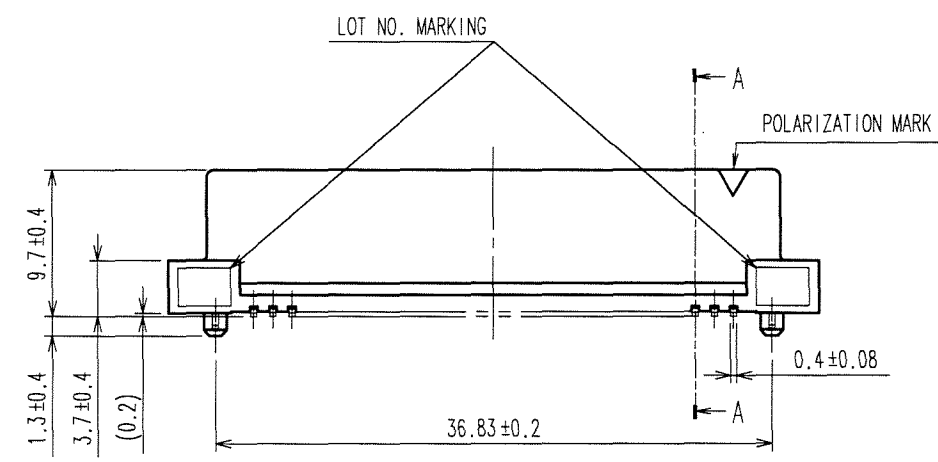
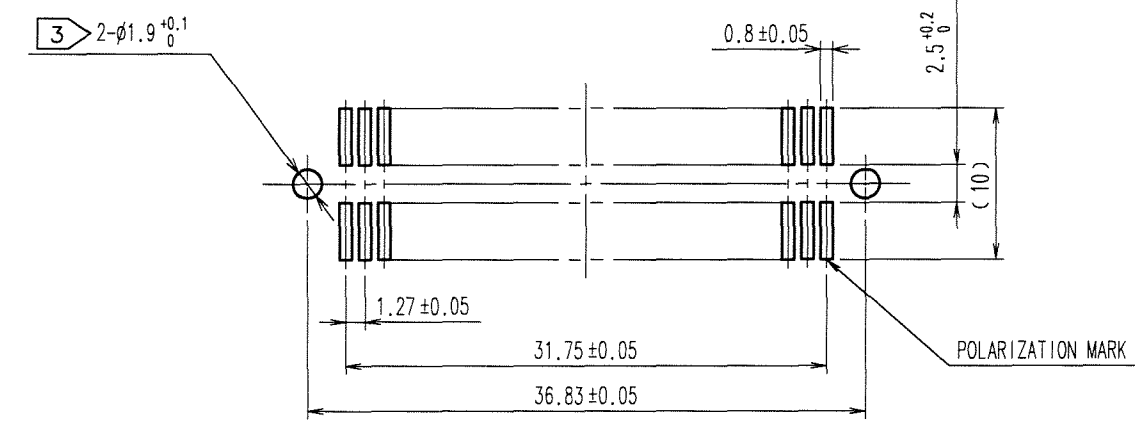

- NOTES
- 1 LEAD CO-PLANARITY SHALL BE 0.15 MAX.
 - 2 THE DIMENSIONS IN PARENTHESES ARE FOR REFERENCE.
 - 3 IN CASE OF THE AUTOMATED MOUNTING, RECOMMENDED HOLE DIAMETER OF BOSS IS SHOWN IN FIG.1.

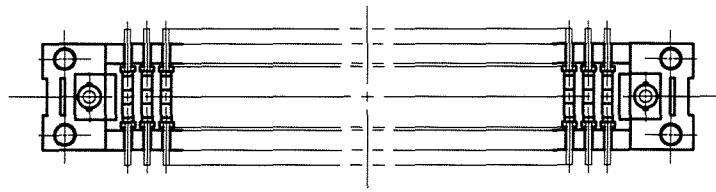

TO
PCK

1	PPS	LIGHT BROWN (UL94V-0)	2	PHOSPHOR BRONZE	CONTACT AREA:GOLD 0.2μ m min. LEAD AREA:TIN-PLATING 2μ m min. UNDER PLATING:NICKEL 1.5μ m min.
NO.	MATERIAL	FINISH, REMARKS	NO.	MATERIAL	FINISH, REMARKS
CODE NO. (OLD) CL		DRAWN A.SUZUKAWA 06.05.22	DESIGNED H. Nakamura '06.05.23	CHECKED K. Ogawa '06.05.23	APPROVED H. Okawa '06.05.23
DRAWING NO. EDC3-082416-21		PART NO. FX2-52S-1.27SV(71)			
SCALE 2 : 1		UNITS mm		CODE NO. CL572-2104-1-71	
HRS HIROSE ELECTRIC CO., LTD		1/1			